

LIBRARY
OF THE
UNIVERSITY OF CALIFORNIA.

Class



127
206
363

TK145
N8

GENERAL

COPYRIGHT, 1907, 1908,

BY

HENRY H NORRIS

Stanbope Press

F. H. GILSON COMPANY
BOSTON, U. S. A.

P R E F A C E.

ELECTRICAL ENGINEERING consists in the industrial application of magnetic and electrical principles. The electrical engineer applies science to industry either by designing and constructing machines and other devices for specific purposes, or by selecting and arranging such apparatus to produce definite commercial results with maximum efficiency. As electrical devices are now in universal use every engineer should be in a sense an electrical engineer. Electrical engineering, once possibly a separate profession, is no longer such, but is becoming more and more a component part of general mechanical engineering.

Having defined electrical engineering as one of application, it is especially important that the student in approaching the subject should have personal knowledge of the *things* and *phenomena* involved before any *reasons* can be ascribed to them. Observation and memory must supply the raw material from which deductions are to be made. We must proceed from the familiar to the new and unknown. Hence the plan of this introductory work is to take the every-day experience of the student as the basis of a general survey of electrical applications. Every one rides on electric cars, uses telephones and electric lights, and in other ways comes into more or less intimate contact with electrical phenomena. By combining with this experience the lessons taught by scientific research, a clear conception of electrical laws should result. These laws may then be used to explain the operation of the numerous devices used in electrical practice.

The study based upon this course is intended to lay a foundation for further analytical work by those who desire it. In combination with practical experience or with laboratory exercises it should be sufficient to enable the student to intelligently select, install, and operate electrical machinery.

The author desires to express appreciation of the courtesy of manufacturers and engineers who have given permission for the reproduction of diagrams, etc. Thanks are due also to Mr. B. C. Dennison of the electrical department, Sibley College, for his work in reading and correcting proof preparatory to the issuing second edition, and for suggestions many of which have been incorporated.

CONTENTS.

CHAPTER.	PAGE.
I. HISTORICAL DEVELOPMENT OF ELECTRICAL ENGINEERING . . .	17
II. FUNDAMENTAL ELECTRICAL AND MAGNETIC QUANTITIES . . .	51
III. MATERIALS OF ELECTRICAL ENGINEERING	72
IV. ELECTRIC CIRCUITS	101
V. MAGNETIC CIRCUITS	130
VI. CONSTRUCTION OF ELECTRIC GENERATORS	148
VII. OPERATION OF ELECTRIC GENERATORS	178
VIII. TRANSFORMERS AND THEIR APPLICATIONS	195
IX. CONSTRUCTION AND OPERATION OF POWER STATIONS	217
X. ELECTRIC MOTORS AND THEIR APPLICATIONS	263
XI. ELECTRIC LIGHTING AND HEATING	303
XII. ELECTRICAL MEASUREMENTS	330
XIII. THE TRANSMISSION OF INTELLIGENCE	352
APPENDIX	374
REVIEW QUESTIONS	379

SYMBOLS USED IN ELECTRICAL LITERATURE.

<i>B.</i>	density of magnetic flux or induction.
<i>C.</i>	electrostatic capacity.
e. m. f.	electromotive force in volts.
<i>E.</i>	e. m. f., effective value.
<i>e.</i>	e. m. f., instantaneous value.
<i>F.</i>	mechanical force.
<i>f.</i>	frequency in cycles per second.
<i>H.</i>	magnetomotive force in gilberts per cm.
<i>I.</i>	current in amperes, effective value.
<i>i.</i>	current, instantaneous value.
<i>j.</i>	$\sqrt{-I}$.
<i>L.</i>	inductance in henrys.
m. m. f.	magnetomotive force.
μ	magnetic permeability.
<i>P.</i>	electric power.
Φ	total magnetic induction or flux.
<i>Q.</i>	quantity of electricity.
<i>r, R</i>	electric resistance.
\mathcal{R}	magnetic reluctance.
<i>t.</i>	time in seconds.
Θ	angle of phase difference.
<i>W.</i>	electric energy or work.
<i>x.</i>	reactance.
<i>z.</i>	impedance.



INTRODUCTION.

THE electric current must be accepted as a fact in nature, just as gravitation or inertia, and it can only be studied through its manifestations. In approaching the subject of electrical engineering it is necessary for the student to recall and to systematize his previous knowledge of the uses to which the current is applied in modern life. It is assumed that he is to some extent familiar with these applications even if the familiarity be only that of a casual observer. To assist him in this review the principal fields of application are here mentioned and briefly illustrated. The order of arrangement is from the standpoint of engineering importance and is merely suggestive. The financial or the economic standpoint might dictate a different order.

Synopsis of Applications of the Electric Current.

1. Distribution of mechanical power.
2. Production of light.
3. Electrolysis.
4. Transmission of intelligence.
5. Production of heat.

1. Distribution of Mechanical Power.

Electric current is used to transmit power from the power station to the points at which it is required. In the station are located prime movers, such as gas engines, steam engines, or water wheels, connected to electric generators which are machines designed to convert mechanical into electrical

power. At the receiving end of the transmission line or circuit, the mechanical power, less the necessary losses in transmission, is reproduced in electric motors. For the present it is not necessary to discuss the principles involved in the transformation of mechanical into electrical power and back again into mechanical power. The important fact is that mechanical power is furnished by the prime movers and is reproduced in the motors, having been transmitted by the

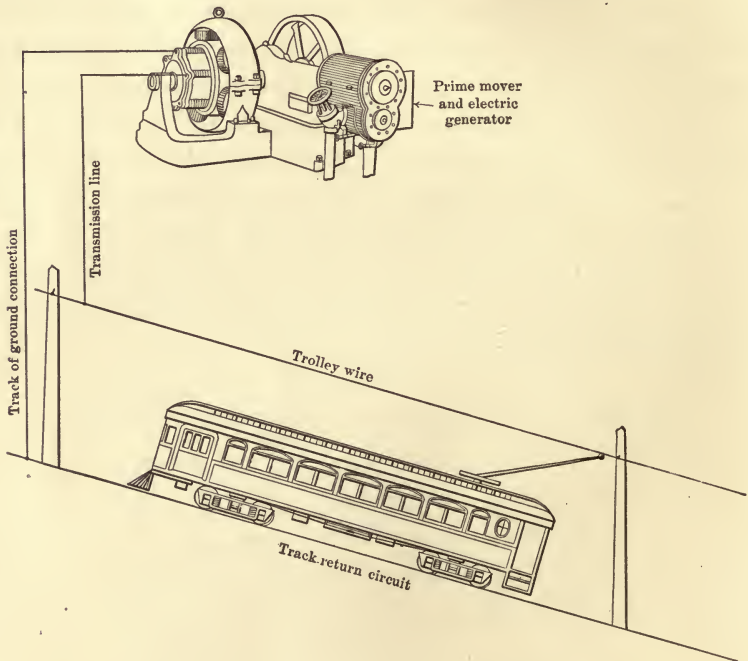

FIG. 1. Trolley car climbing grade, showing a familiar example of mechanical power transmission through the electric circuit.

electric current through the circuit. While it is true that power can be transmitted by means other than electrical, none of these can compete over considerable distances. It is



FIG. 2. Map of the transmission lines of the Ontario Power Company illustrating the case of transmission of power by electrical means.

interesting to note that power is being transmitted electrically a distance of two hundred miles or more.

Examples of Power Transmission. A trolley car climbing a grade furnishes a concrete illustration of mechanical power transmission. The power station furnishes current through the feeders and trolley wire and the rail return. In the motors which are mounted upon the car axles, the electric power is changed into mechanical form and drives the car against friction and grade resistances. The electric circuit, which includes the generator, line, and motors, acts merely as a connecting link between the engines and the driving gear of the car.

Another striking illustration of power distribution is furnished by the lines radiating from Niagara Falls. Five great power plants transform several hundred thousand horsepower. Part of this is used in the vicinity, but a large part is transmitted to Toronto, Lockport, Buffalo, Rochester, Syracuse, and other cities within a radius of two hundred miles, and the range is constantly extending. The electric power is used for any purpose that could be accomplished by power plants located at the points of demand.

2. Production of Light.

When electric current is forced through a circuit, heat is generated, and the amount produced depends upon the nature of material and upon its dimensions. It is evidently more difficult to pass a current through a long conductor of small cross-sectional area than through a short one of large area. In other words, the smaller conductor offers more *resistance* to the passage of the current than the large one. When the amount of heat generated in any part of a circuit is sufficiently great light is given off. This light is of two kinds, which are given the names *incandescence* and *luminescence*.

Incandescence is due to the high temperature of the substance, and the intensity has a definite and well-known relation to the temperature without regard to the substance heated.

Luminescence, sometimes called "cold light," while depending somewhat upon the temperature, also involves a property possessed by some materials of generating light waves in greater quantity than can be accounted for by *incandescence*. This process is frequently named *selective radiation*.

The most common examples of incandescent light are furnished by the incandescent and the plain carbon arc lamps. In the former a filament of carbon or metal is heated in vacuum

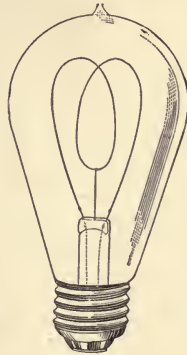

FIG. 3. A carbon filament incandescent lamp in which electrical power is changed into heat and light.

by the current to a temperature of several thousand degrees centigrade. This temperature is carried as high as the material will allow, but it must always be kept far below the boiling point of the filament in order to minimize the gradual distillation of the material. In the arc lamps the current flows between two carbon points separated by a short distance (one-eighth to three-eighth inch) and connected by a stream of carbon vapor. The current in overcoming the resistance offered by the vapor path or arc heats the carbon tips to

such a temperature that they become incandescent. In producing the vapor which forms the arc the carbon boils. As car-

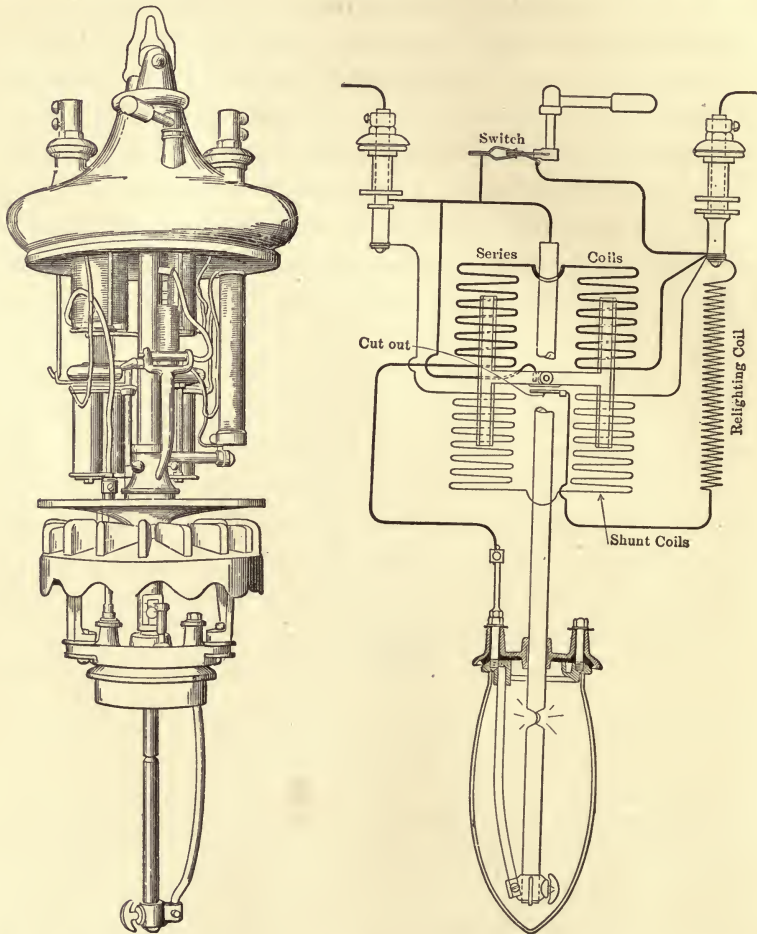

FIG. 4. View and diagram of the carbon arc lamp in which light is produced by the heat generated in the arc.

bon is practically the most refractory of conductors, the arc temperature is the highest which can be produced. A slight

amount of light also comes from the arc, but this is small compared with that thrown out from the tips.

Luminescent light sources are now attracting attention, and may in time displace the other forms. As a rule, they

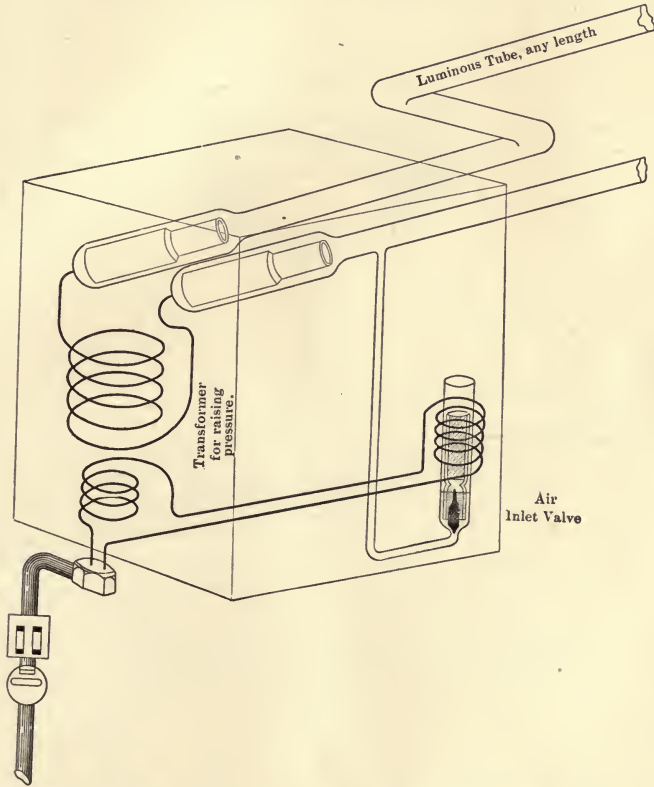

FIG. 5. Vacuum tube lamp, which gives out light at low temperature and with small luminous intensity.

produce light more efficiently than the ordinary arc and incandescent lamps. An excellent non-electrical illustration of the principle is found in the Welsbach gas mantle. This mantle is composed of thorium oxide, which when heated to a comparatively low temperature gives off light. Among

electrical lamps involving selective radiation the principal examples now coming into use are the vacuum tube, the mercury vapor tube, and the flaming arc. The first of these consists of a long tube, exhausted to a low pressure. The current passing through the rarefied gases produces a soft, white light.

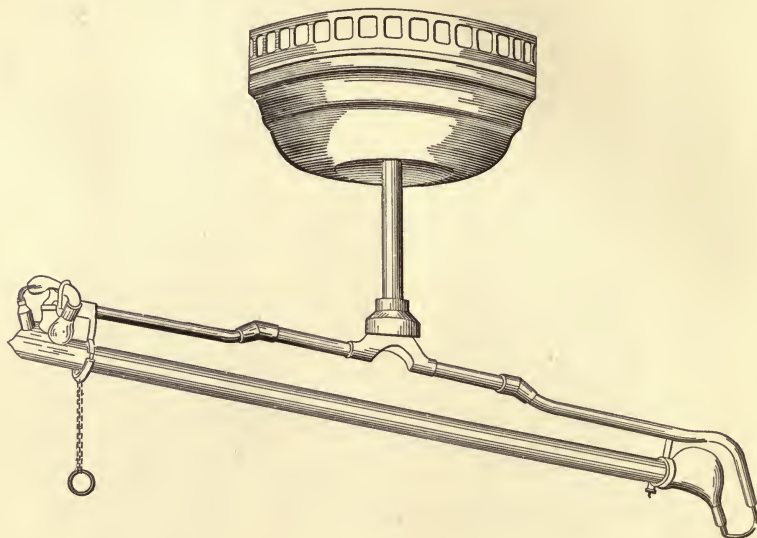

FIG. 6. Mercury vapor lamp, in which a greenish light is produced by an arc maintained through mercury vapor.

The mercury arc is produced in a tube of moderate length exhausted to a low pressure. The heat produced by the current maintains a supply of vapor from a reservoir of metallic mercury connected to the tube, and the vapor forms a conducting path for the current. The mercury arc gives off a greenish light at a high efficiency. The flaming arc lamp produces the most highly efficient light now known, by means of substances added to the carbons, calcium being one of the best materials for this purpose. The calcium particles are maintained by the

arc at such a temperature as to render them highly luminous. The arc then becomes the source of light rather than the carbon tips as in the ordinary carbon arc. The carbon furnishes the vapor which acts as a carrier for the luminous substance.

3. Electrolysis.

Electrolysis is the name given to chemical decomposition produced by the electric current. When a current is passed through a salt in solution or through fused salt, between con-

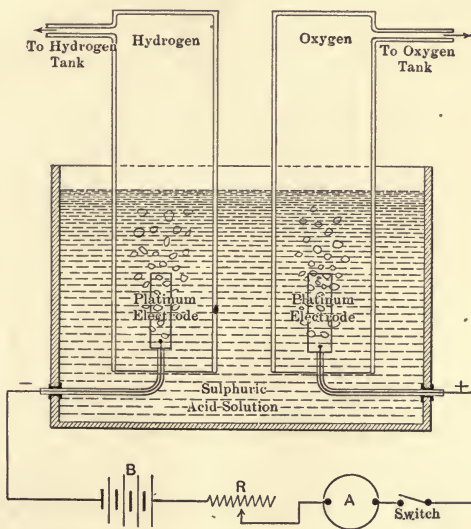

FIG. 7. Gas generator, in which the current decomposes water into oxygen and hydrogen at the two electrodes.

ducting terminals or electrodes immersed in the liquid, or electrolyte, decomposition of the salt usually occurs. There is a breaking up of the chemical compounds and a recombin-

ation of the elements. The decomposition is apparent in one or more of the following ways:

- (a) Resolution of the liquid into gaseous compounds.
- (b) Decomposition of the base of the salt in solution.
- (c) Chemical changes in the electrodes.

As an example of the production of gases from a liquid take the case of the oxy-hydrogen generator. Two jars are inverted in a tank containing a sulphuric acid solution. Inside

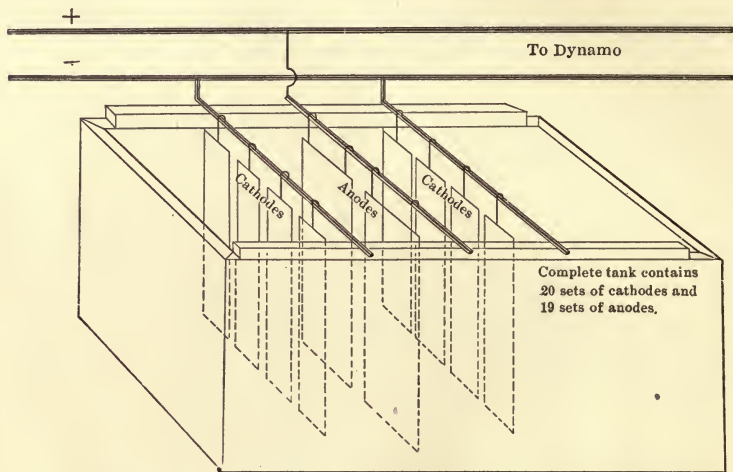

FIG. 8. Refining tank for copper, which is deposited by the current from a copper sulphate solution.

the jars are platinum or lead electrodes between which the current flows. The decomposition of the solution results in the liberation of oxygen at the positive plate or anode through which the current enters, and hydrogen at the negative plate or cathode. From the jars the gases are piped to storage tanks or gas holders.

In electrolytic refining of copper occurs an excellent illustration of the decomposition of the base of a salt. The copper

to be refined is first cast into slabs which are suspended in a copper sulphate solution. In the same tanks are thin sheets of copper which form the negative plates and upon which is deposited the copper dissolved by the current from the anode slabs. This method of refining produces practically pure copper.

The storage battery is the most important application to engineering practice of the electrolytic changes in electrodes.

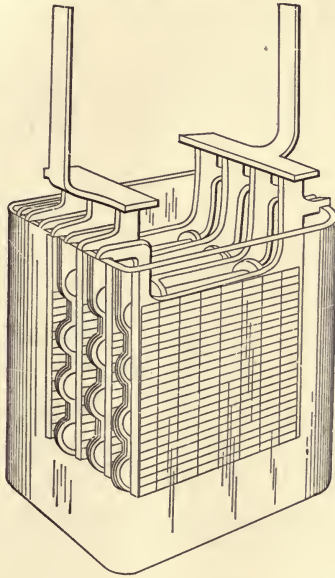

FIG. 9. Storage cell, in which energy is stored in chemical form through oxidation and reduction of lead electrically.

In the ordinary lead type of cell with sulphuric acid solution as electrolyte, the energy supplied by the current in electrical form reduces the active material on the negative plates to spongy lead and oxidizes that on the positive plates to lead peroxide. The energy thus stored may be partially recovered by connecting the positive and negative terminals of the cell through an electric circuit.

4. Transmission of Intelligence.

The electric current furnishes the only convenient means for transmitting speech or signals to a considerable distance. This is accomplished by varying the duration of the current as in the telegraph, or by varying the intensity of the current as in the telephone. A simple telegraph circuit comprises a

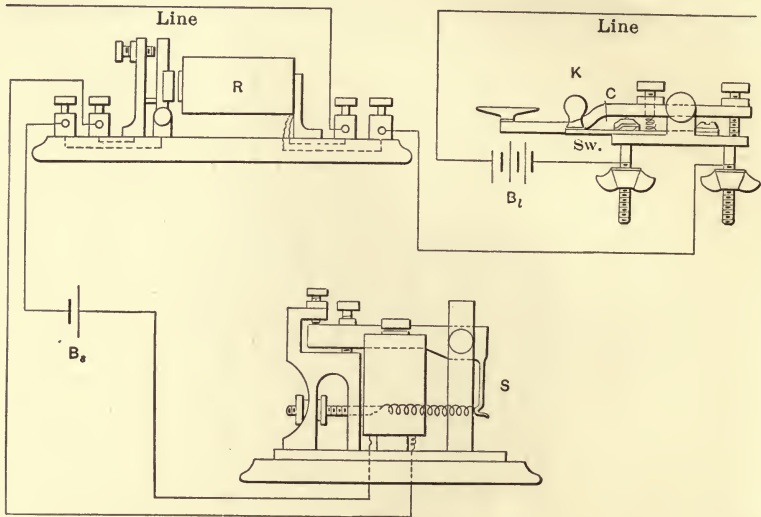

FIG. 10. Simple telegraph circuit showing, R, relay; K, key; Sw. switch; C, contact; Bl., line battery; Bs., local battery; S, sounder.

battery, sounder, and key, all connected in series. The key closes the circuit for long and short intervals, known as "dashes" and "dots," and combinations of these signals represent the letters of the alphabet. The sounder comprises a small electro-magnet which attracts a plate of iron, or armature, when energized by the current. The armature is carried by a lever pivoted at one end. The free end of the lever plays between upper and lower limit stops, producing two characteristic sounds. The intervals between the two

sounds indicate the duration of current in the magnet coils. In the simple telephone circuit there are the transmitter, the battery, and the receiver. The transmitter comprises a diaphragm against which the speaker talks. Connected to the diaphragm is a carbon contact, the pressure upon which is varied by the vibration of the disk under the action of the sound waves. The variable pressure upon the carbon contact varies the electrical resistance and therefore the amount of current in the circuit. The receiver contains an iron dia-

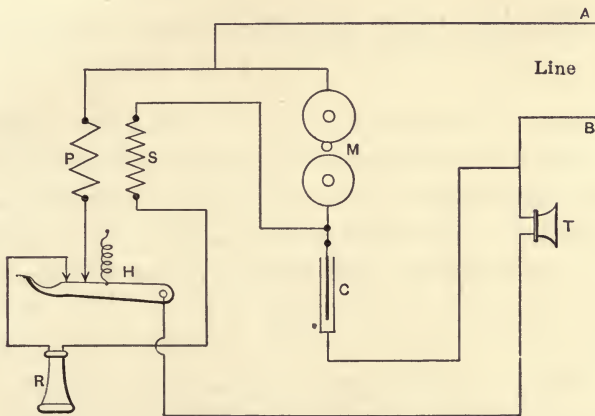

FIG. 11. Simple telephone circuit showing T, transmitter ; A, B, line wires ; C, condenser ; M, ringer ; P, S, transformer or induction coils ; H, switch ; R, receiver.

phragm placed near the end of an electro-magnet. The coil of this magnet carries the varying current from the transmitter, and the current reproduces the sound waves, impressed upon the transmitter, by attracting the receiver diaphragm with varying force. When applied to the requirements of actual business numerous other devices are necessarily used in connection with those described, but the essential principles are the same.

5. Production of Heat.

The production of heat has already been referred to in connection with light, but there are other applications of electrically produced heat, such as cooking, car warming, etc., which

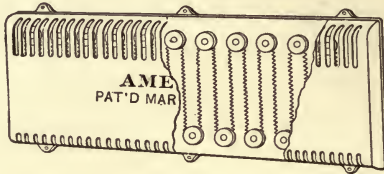

FIG. 12. Electric car heater, used for car warming, producing heat by the flow of current through a high resistance.

are finding an increasing field of usefulness. Electrical heating devices are of simple construction, consisting merely of a wire of high resistance surrounded with insulating material and imbedded in the body to be heated. This method of heating is very efficient as all of the electrical energy is turned

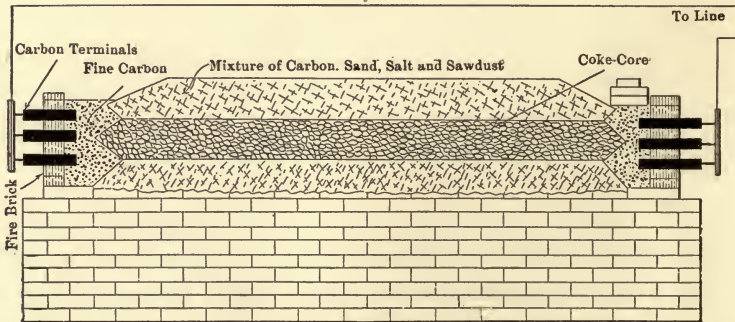

FIG. 13. Carborundum furnace, an important application of electric heating. Shows the arrangement of coke and sawdust core.

into heat. Such applications of electrical heating as have been described are of trifling importance as compared with those

found in electro-metallurgy. By means of the electric arc and the passage of current through high resistance paths in masses of material to be heated it is possible to produce reactions not otherwise practicable. For example, the abrasive material known as "carborundum" is produced by heating a mass of carbon and sawdust to high temperature with the current. Artificial graphite is similarly produced, and new discoveries in this line are being constantly made. Aluminum reduction, while essentially an electrolytic process, involves the use of electric heating. The aluminum oxide which is reduced by electrolytic action is carried in a mass of fused cryolite which is maintained in a fluid condition by the heat produced by the current.

Summary.

In the preceding paragraphs a general survey of the uses of electricity in every-day life has been given with a view to preparing the way for a more detailed study. As these applications are viewed as a whole, one important fact stands out above all others. This is that every use to which electricity is put involves a *transformation of energy*. In the first illustration it is from mechanical to electrical form and back again. In producing light the energy is largely lost in heat, but incidentally some light energy is generated. In electrolysis the energy takes the chemical form from which it can be restored to mechanical energy in many cases. The transmission of intelligence involves the transformation to sound energy in the instances which have been cited, although, as in the case of light, only a small proportion is so transformed. Finally, in heat generation all of the electrical energy disappears as such and reappears in thermal form from which it can be recovered only by a roundabout and inefficient process. All of this goes to show that the *electric current offers a con-*

venient means for transmitting and transforming energy, and nothing else. The study of electrical engineering, therefore, is that of the means used for economically producing these transformations. It is essential that the student have this fact continually before him, and that all so-called generators, motors, etc., be viewed merely as energy transformers. Energy cannot be "generated"; it can only be transformed.

CHAPTER I.

HISTORICAL DEVELOPMENT OF ELECTRICAL ENGINEERING.

OUTLINE — PERIOD OF MYSTERY. PERIOD OF SCIENTIFIC PREPARATION.

Generation and Conduction of Electricity.
Storage of Electricity.
Exact Scientific Work.
Current Electricity and its Effects.
Electro-Magnetism and Magneto-Electricity.
Summary.

PERIOD OF COMMERCIAL DEVELOPMENT.

Transmission of Intelligence.
 Early telegraph systems.
 Advances in telegraphy.
 The telephone.

Electric Lighting and Heating.
 Early incandescent and arc lamps.
 Development of the incandescent lamp.
 Development of arc lamps.
 Recent improvements in electric lamps.
 Electric heating.

Electro-Chemistry.
 Early experiments in electro-decomposition.
 The storage battery.
 Copper refining.
 Other processes.

Electric Power Generation and Transmission.
 Early direct current generators.
 Early alternators.
 The transformer.
 Power transmission.
 Early electric motors.
 Recent electric motors.

Electric Traction.
 Early period.
 Commercial application.
 Recent developments.

A survey of the history of the development of electrical engineering shows that it consists roughly of three periods.* The first comprises the time up to the beginning of the seventeenth century, and may be termed the *period of mystery*, from the attitude of the people toward the few known phenomena. Between the years 1600 and 1830 was a *period of scientific preparation* for the *period of commercial development* which continues to the present time.

Period of Mystery.

The fact that amber when rubbed attracts light objects has been known for at least two thousand years. No particular scientific use was made of this knowledge until the beginning of the seventeenth century. The name *elektron*, from which our word *electricity* is derived, was given to the attractive property of amber by the ancient Greeks. The name indicates the yellow color of the substance which reminded them of the sun. The property of attracting iron bodies possessed by an iron ore, lodestone, was also a matter of common knowledge in very ancient times. It is supposed that the words magnet and magnetite were applied to the lodestone on account of the name of the province of Magnesia in Asia Minor, in which large quantities of the ore were discovered.

The two fundamental phenomena of electric and magnetic attraction underlie our present knowledge of electricity and magnetism. No connection between these two was suspected

* References: *Priesley*, History and Present (1769) Status of Electricity; *Faraday*, Experimental Researches in Electricity and Magnetism; *Gilbert*, de Magnete, Lodestone and Magnetic Bodies, translated by Mottelay; *Arago*, Papers before French Academy of Science; *Barlow*, Magnetic Attractions; *Benjamin*, Age of Electricity, Intellectual Rise in Electricity; *Mendenhall*, Century of Electricity.

until each had led to much successful research. The connection, although suspected for some time, was not experimentally established until 1820. The only practical use made of either of these attractions up to 1752, the date of the invention of the lightning rod, was the mariner's compass, the history of the origin of which is obscure. It appears not to have been invented at any particular time or place, but was undoubtedly known to several ancient peoples. Its first appearance in Europe is placed in the thirteenth century, and from that time on it was in general use on shipboard in a very crude form. During the period of mystery there was unlimited speculation regarding the relation of electrical and magnetic attractions. There was, however, little experimental basis for the theories advanced.

Period of Scientific Preparation.

The scientific period began with *Dr. Wm. Gilbert* (London,* 1540*-1603, advisory physician to Queen Elizabeth), who absorbed the knowledge of his time, corrected and verified previous hypotheses, and placed the study of electricity and magnetism upon a sound scientific basis. His chief writing, "de Magnete," published in 1600, contains the results of laborious and expensive research. It was the cause of further study by numerous other philosophers who discovered one by one the fundamental electrical and magnetic laws. Gilbert disproved a number of fallacies intended to explain electric and magnetic attraction, and he demonstrated that many substances beside amber may be electrified by rubbing. He studied the nature of magnetic poles and gave a rational explanation of their properties.

* The places mentioned in connection with the names of prominent scientists and engineers are those in which their important work was accomplished; the dates are of births and deaths.

Generation and Conduction of Electricity. Gilbert's studies did not immediately bear fruit, but as an indirect result the electric machine was invented in 1672 by *Otto von Guericke* (Magdeburg, 1602-1686), the inventor of the air pump and other useful pieces of apparatus. His electrical machine consisted of a sulphur globe rubbed by hand



FIG. 14. Smith forging iron in magnetic meridian. From Gilbert's "de Magnete," published 1600.

to electrify it. In 1675 *Sir Isaac Newton* (Christmas Day, 1642 — March 20, 1727) improved the machine by substituting glass for sulphur, thus producing in principle the electrical machine of to-day. Up to the time of von Guericke and Newton the attractive property was supposed to be confined to the rubbed substances. The former discovered that it could be conducted along a thread. Unfortunately his experiments in conduction were forgotten, and the possibility of

transmitting electricity was not rediscovered until 1729. At this time *Stephen Gray* (London, date of birth unknown, die 1736) found that an ivory ball possessed the ability to attract light bodies when connected with an electric machine by a thread. Incidentally he also discovered the ability of silk to insulate the conducting thread.

Gray's work furnished the inspiration for more scientific research by *Charles F. Du Fay* (Paris, 1698-1739). In 1733 he made a long series of observations in the line of Gray's experiments. As a result he was able to separate materials into two general classes, conductors and non-conductors. He also improved upon Gray's silk insulator by making solid ones of glass and wax. He constructed a transmission line of some length through which the influence of the electrical machine was conducted. Du Fay made the astounding discovery that while some substances when rubbed attract light bodies the latter are repelled by other substances similarly treated. He, therefore, assumed that there were two kinds of electricity.

Storage of Electricity. The possibility of generating electricity readily by means of Newton's machine and, through the discoveries of Gray and Du Fay, conducting it, led to the popularizing of electrical experiments. While making some such experiments about the year 1745, *Peter van Musschenbroeck* (Leyden, 1692-1760) found that electricity could be stored in a bottle. His first electric bottle consisted of a glass jar filled with water and held in the hand. A wire passed through the cork, the lower end being immersed in the water. The jar was charged by applying the outer end of the wire to the terminal of an electric machine. Thus charged the jar could be carried about and would hold its electricity for some time. The water and the hand were soon replaced by metallic coatings inside and

out of the bottle, resulting in the form of Leyden jar in use at the present time. It should be noted that some years before this important invention, the possibility of inducing electric charges on bodies was known, in fact most of the popular experiments were in this direction. It did not occur to anyone, however, that the electrical charge could be stored in a body electrically independent of the source of the charge.

The invention of the electric bottle stimulated popular interest, and soon after the experiment was repeated in several countries. Some of the apparatus was sent to *Benjamin Franklin* (Philadelphia, Pa., 1706-1790), in 1747, by a London correspondent. The philosopher immediately began experimenting with the bottle and theorizing regarding it. As a result he announced the theory that there was but one kind of electricity, its absence producing one effect and its presence another. Franklin's studies with the electric bottle convinced him of the identity of lightning and electricity, which he was able to prove experimentally in 1752. Thus the lightning rod was invented, the first commercial application of electrical principles. Electricity had been used in the treatment of disease before this time, but not in a scientific manner and with very dubious results.

Exact Scientific Work. Up to the middle of the eighteenth century numerous experimental data had been collected and were available for the production of mathematical and physical theories of electricity and for precise measurements. The latter were used as checks upon the theory, and at the same time they furnished the raw material for further analysis. Among those who made such studies were *Henry Cavendish* (London, 1731-1810) and *Charles A. Coulomb* (as military engineer was located in various parts of France, 1736-1806). Cavendish studied the relative electrical conductivity of various substances and also the chemical effects produced by electricity, Coulomb

devoted attention particularly to the attraction of charged bodies and deduced the law which is now known by his name.

Current Electricity and its Effects. *Dr. Luigi Galvani* (Bologna, 1737-1798) was also much interested in electrical experiments. He had occasion to dissect some frogs' legs, and these were accidentally brought into contact with two dissimilar metals. The twitching of the frogs' legs suggested to Dr. Galvani that he had discovered a source of



FIG. 15. Volta's electric pile and the "frog-leg" experiment of Galvani repeated by its use.

electricity in the animal matter. His discovery attracted the attention of *Prof. Alessandro Volta* (Pavia, Italy, 1745-1827), who disagreed with Galvani as to the source of the electricity, and believed that it came from the contact of two dissimilar metals. To prove this conclusively he constructed a pile of pairs of disks of dissimilar metals, each pair separated from the next by moistened paper. The apparatus, the forerunner of the primary cell, was known as the *Volta pile*. Volta's discovery placed at the disposal of experimenters a source of electricity much more convenient

than the electrical machine of the time, and it gave more stimulus to study and experiment. One of those to make the first use of Volta's discovery was *Sir Humphry Davy* (Bristol and London, Eng., 1778-1829). In 1802 with the aid of a large number of voltaic cells he was able to heat a platinum wire to whiteness and to produce an arc between two carbon points. This invention of the electric light indicated the practical possibilities of the rapidly developing science. In 1807 Davy also produced chemical decomposition by means of the current.

Electro=Magnetism and Magneto=Electricity. Up to the beginning of the nineteenth century electrical knowledge had developed to such an extent that practical applications were beginning to result. Some slight use had also been made of magnetism, but the relation of these to each other was only suspected. In 1819 and 1820, *Prof. Hans Christian Oersted* (Copenhagen, 1777-1851) discovered that there was an actual connection between magnetism and the electric current. While performing some experiments before his class he placed a wire carrying a current in the neighborhood of a magnetic needle and noticed that the latter was deflected. When the news of this experiment reached *André-Marie Ampère* (Lyons, France, 1775-1836) he at once perceived the importance of the discovery and devoted himself to the verification of Oersted's statements and to developing a theory to explain them. In the short space of one week he performed this feat and gave a rational treatment of the relation of the magnetic field to the electric current. In the same year *Dominique-François Arago* (Paris, 1786-1852) discovered that magnetism could be produced in other bodies by the current. This was a step in advance of Oersted. In 1825 he performed an experiment in which a metal disk was revolved before a magnet. He found that the magnet tended to follow the disk. Arago's experiments appealed particularly to a young man who at this

time was assistant to Sir Humphry Davy. *Michael Faraday* (London, 1791-1867) was much interested in the electrical work going on in Davy's laboratory. In pondering the cause of the reaction produced between the disk and the magnet in Arago's experiment he conceived the idea that electricity was induced in the disk by its motion near the magnet. Between 1825 and 1831 he made many experiments to prove this, and by the latter year had systematized the knowledge of this subject in a remarkable manner. The important facts discovered by Faraday were as follows: "When an electric current is passed through one of two parallel wires, it causes at first a current in the opposite direction in the other; but this current is only momentary, notwithstanding the inducing current is continued. When the first circuit is broken, another current is produced in the wire under induction, of about the same intensity and momentary duration, but in the opposite direction to that generated at first.

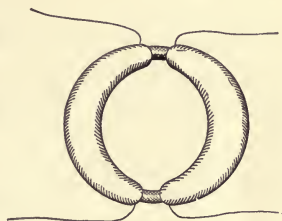

FIG. 16. Ring and coils as used by Faraday in his experimental researches and with which the laws of electro-magnetic induction were discovered.

"If a coil of wire whose ends are joined, through a galvanometer or otherwise so that a current can pass, be brought up to a magnet, or if the magnet be made to approach the coil, a current will pass through the coil. This current will not be permanent, but will exist only during the motion of approach. If the magnet and coil be separated, a current will again be induced, but, as in the previous case, its direction will be opposite to that of the first."*

Faraday's most important discoveries were made in a very short period. Naturally they stimulated other workers.

* T. C. Mendenhall, "A Century of Electricity."

Faraday was able by means of a modification of Arago's experiment to produce current by the motion of the disk, and in effect invented the dynamo. *Peter Barlow* (Woolwich, England, 1776-1862) reversed the operation of Faraday's disk by sending a current through it, thus producing the electric motor. Contemporaneous with Faraday, but independent of him, was *Prof. Joseph Henry* (Albany, N. Y., 1797-1878). Between

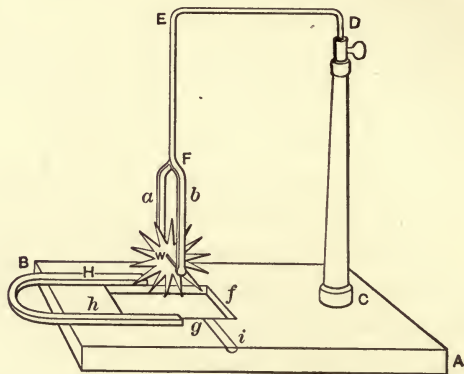

FIG. 17. The original electric motor as constructed by Peter Barlow and shown in his book published in 1824.

the years 1829 and 1831, among other important pieces of electro-magnetic apparatus, he constructed powerful electro-magnets by winding upon iron bars coils of wire insulated laboriously by hand. Similar magnets were at the same time constructed in England by *William S:urgeon* (Manchester, England, 1783-1850).

In comparing the work of Henry and Faraday it will be noted that the former was most interested in the production of magnetism from electricity. Faraday studied carefully the induction of electricity from magnetism. Thus, while Henry prepared the way for the many applications of the electro-magnet, Faraday practically invented the transformer, the dynamo,

SUMMARY OF THE PERIODS OF MYSTERY AND OF SCIENTIFIC PREPARATION.

Magnetism.

Electricity.

Magnetic attraction, lodestone, antiquity.

Electric attraction, amber, antiquity.

Mariner's compass, origin unknown, used at least as early as 13th century.

Gilbert, researches published "de Magnete," 1600.

Gilbert, researches latter part 16th century.

Guericke, Electric Machine, 1672.

Newton, Electric Machine, 1675.

Gray, Electric Conduction, Insulation, about 1729.

Du Fay, separated conductors and non-conductors, two-fluid theory of electricity, 1733.

Musschenbroek, Leyden jar, 1745.

Franklin, identity of lightning and electricity, the lightning-rod, 1747-1752.

Cavendish and Coulomb, scientific and analytical work in electricity, latter part of 18th century.

Galvani, current electricity, "frog-leg experiment," 1786.

Volta, the primary cell, 1793.

Davy, the arc light, chemical decomposition, 1802-1807.

Oersted, magnetic effect of current, 1820.

Ampere, scientific and analytical study of Oersted's work, 1820.

Arago, magnetic induction from current, mechanical effects, 1820-1825.

Faraday, electro-magnetic induction, the dynamo, transformer, etc., 1825-1831.

Barlow, Elements of electric motor, 1820-1824.

Henry and Sturgeon, the electro-magnet, 1829-1831.

and other modern devices. With these men the preparatory period of electrical development may be said to close. Before their scientific work was completed, however, practical applications were already being made.

Period of Commercial Development.

By the year 1830, all of the principles necessary for the commercial development of electrical engineering had been discovered. The static electric machine was practically perfect. The conduction of static electricity along wires was well understood, and materials had been separated into conductors and non-conductors. The knowledge of current electricity had progressed to such a point that it was possible to produce a limited supply by chemical and mechanical means. The Leyden jar in a practically perfect form permitted the accumulation of electricity for experimental uses, and the arrangement of these jars in batteries gave sufficient capacity for all purposes to which static electricity could be applied. The identity of lightning and electricity had been established, and a practical lightning rod for protecting buildings had been developed. The laws of electro-magnetic induction had been systematically investigated, and magnetism had been produced from the electric current. Arc and incandescent lights had been produced, and substances had been electrically decomposed. These elementary facts and laws were sufficient when commercially developed to produce all of the electrical devices of the present day.

The growth of electrical engineering from 1830 to the present time has occurred along a number of different lines, all to some extent related but more or less independent. It will be convenient to summarize the commercial development under a number of different topics.

Transmission of Intelligence ; Early Telegraph Systems.

As early as 1774, a telegraph system using a number of different wires connected to pith balls had been devised. Signals were transmitted by supplying these pith balls with electric charge through their respective conducting lines, the different pith balls representing the letters of the alphabet. Forty years later this device was improved by reducing the number of wires to one, the pith balls being mounted upon a wheel rotating synchronously with another at the sending end of the line. Up to this time transmission was by means of static electricity. About 1828 current electricity was used for transmitting signals by producing a change in the color of moist litmus paper moving under a contact finger. All of this development was preliminary to the electro-magnetic telegraph made possible by the discovery of Professor Oersted in 1820. As soon as the magnetic effect of current was discovered, the invention of a telegraph system, involving the deflection of magnetic needles by the current, was the immediate result. Ampère devised a system employing several wires and deflecting needles, the movements of which represented the letters of the alphabet. The needle telegraph became immediately popular, and in 1832 there was produced a practical 36-needle arrangement with a signal to attract the attention of the receiving operator. A few years later *Sir Charles Wheatstone* (London, England, 1802-1875) devised a 5-needle equipment and afterward reduced the number of needles to one. This plan was put into commercial operation and was fairly successful. In this country, and at the same time, *Prof. S. F. B. Morse* (Charlestown, Mass., 1791-1872) was working on a printing or recording device, utilizing Professor Henry's electro-magnet. His first apparatus, which is illustrated in Fig. 170, Chap. XIII, was a device for recording dots and dashes upon a moving strip of

paper. In 1844, after numerous discouragements, Professor Morse received a small appropriation from Congress for the construction of an experimental line between Baltimore and Washington, and over this the first message was sent on May 27, 1844. It was soon found that messages could be taken by sound from the recorder, and the system was thus simplified by substituting a "sounder" for the recorder in many cases. The recorder in improved mechanical form is still in use for particular classes of service.

Advances in Telegraphy. The advances in telegraphy since Morse's invention have consisted principally in improving the transmission system. The first step in this direction was the invention by *Thomas A. Edison* (Menlo Park, N. J., 1847—date), in 1872, of a method permitting the sending of two messages over a wire at the same time. This "duplexing" of the system led to further invention along the same line, resulting two years later in the "quadruplex" of the present day. From the first a most important feature in rendering possible the extension of telegraph circuits was the "relay." This is a very sensitive electro-magnetic device for connecting a battery in each local circuit with the sounder or recorder in that circuit. The line current passes through the bobbins of the relay which attract an iron armature attached to a contact lever. The movements of this lever "make" and "break" the local circuit, reproducing in it the impulses received from the line.

Another method of improving the line efficiency is by sending the signals very rapidly. Automatic systems have been successfully developed for this purpose but have not been adopted on a large scale commercially. In one plan a tape is perforated with holes so placed that they represent the Morse signals. The tape is fed through a contact-making

device which transmits current to the line when the holes pass under the contact fingers. The decomposition of the substance in the paper by the current produces marks which are legible to a person familiar with the Morse code.

The latest development in the transmission of signals is wireless telegraphy, which differs radically in principle from other systems. In general it may be said that the transmission involves the use of electric waves in the ether. The properties of these waves were discovered by *Prof. Heinrich Hertz*, and they are frequently called Hertzian waves. These waves are set up by the discharge of an induction coil, and they are radiated throughout space. In utilizing the waves for telegraphy they are received on a collecting wire which transmits them to the ground through a sensitive resistance known as the coherer. The coherer consists of masses of metal particles or of an electrolytic cell. Either of these has its resistance temporarily decreased by the passage of the electric waves. The coherer is connected in a local battery circuit, and the signals are reproduced in a telephone, a telegraph sounder, or other apparatus.

The Telephone. The application of the electric circuit to the transmission of speech came naturally much later than the telegraph, which merely transmits signals. The first ideas of transmitting sound electrically date back to the middle of the last century when musical sounds were actually so transmitted. It remained, however, for *Prof. Alex. Graham Bell* (Boston, Mass., Washington, D. C., 1847—date) to transmit speech. Bell exhibited at the Centennial Exposition of 1876 a crude form of telephone, containing the fundamental principles of the present receiver. It was an application of the studies of Oersted, Faraday, and Henry by which the

vibration of a metal diaphragm, under the action of sound waves, was made to vary the strength of an electro-magnet and by induction that of a current in a coil surrounding it.

The next important step in telephone development was the production of an efficient transmitter. Bell's apparatus was entirely satisfactory as a receiver, and in modified form is in use at the present time. *Prof. Elisha Gray* (Chicago, Ill., 1835-1901) invented a transmitter in which the vibrations of a disk varied the resistance in a circuit, the current being supplied from an outside source. He was thus able to introduce much more power into the transmitting circuit than was possible in Bell's device. This principle underlies all transmitters of the present time. Other inventors devised transmitters working on the same general principle but differing in the manner in which the variable resistance was produced. *Emile Berliner* (Washington, D. C., 1851- date) in 1887 applied the principle to contact resistances, whereas Gray varied his resistance by the degree of immersion of a metal needle in fluid. Edison, *Prof. D. B. Hughes*, *Henry Hunnings*, *Francis Blake*, and others varied the details of the transmitter construction without altering the principle. The only essential addition to the original inventions was the use of an induction coil in connection with the transmitter to raise the transmission pressure and thus increase the range of transmission. With a satisfactory transmitter and receiver the next step in the development of the telephone was the production of switchboards for connecting the subscribers together. Soon after the invention of receiver and transmitter, a switchboard was installed for commercial use. From this crude board, which served merely to connect the subscribers' circuits, the present elaborate systems have been developed. In the early years of commercial development, signaling was accomplished by means of a magneto-generator located at each sub-

scriber's instrument. This machine sent alternating current through the line and operated a specially constructed bell. At the present time the alternating current for ringing and the direct current for the talking circuit are furnished from the central office over the same circuit, a condenser being employed to permit the passage of the alternating current through the local bell circuit, while an inductance coil in the talking circuit allows direct current to pass and keeps out the alternating current.

Electric Lighting and Heating; Early Incandescent and Arc Lamps. During the first few years of the nineteenth century, Sir Humphry Davy produced both arc and incandescent light. His source of power was the primary battery, the limitation of which discouraged the development of his discoveries. By the use of two thousand cells of battery he produced an arc, the name indicating the arched form taken by the stream of carbon vapor. He heated platinum wire to incandescence by means of the current, but as this platinum was in the air it was soon destroyed by oxidation.

Development of the Incandescent Lamp. The first patent to be granted for an incandescent lamp was in 1845, the inventor being *J. W. Starr* of Cincinnati, Ohio. The patent was taken out in Great Britain, and the first American patent was dated June 29, 1858. Little use was made of the inventions, owing to the lack of cheap current. As soon, therefore, as a practical electric generator was produced the interest in electric lighting increased. It remained for Thomas A. Edison to place the incandescent lamp on a commercial basis, which he succeeded in doing, after an extensive series of experiments, in 1879. Shortly before this he had made platinum

filament lamps which were fairly successful, but in the year mentioned he produced a durable carbon filament operating in a vacuum. Edison was not the first to use a vacuum or a carbon filament, but he combined the results of previous experiments with his own in such a way as to enable him to make a commercial form of lamp. Contemporaneous with Edison has been *Sir Joseph Wilson Swan* (London, England, 1828—date), to whom is due a large share of credit for the development of the incandescent lamp in England. Since the time of the patents of Edison and Swan, improvements in the incandescent lamp have until recently been largely in their mechanical construction. At the present time the lamp is in a process of transition, apparently back to the metal filament. Platinum is not the metal now employed, but the more refractory tungsten, titanium, tantalum and other rare metals are coming into use. The chief improvement in the carbon filament consists in raising it during the manufacture to a very high temperature producing a change in the form of the carbon, and permitting it to be operated at a much higher temperature. The word "metallized" is applied to this improved filament from its resemblance to metal wire. The result of these recent inventions has been to reduce power consumption in the lamp for a given output of light.

Development of the Arc Lamp. The arc produced by Davy needed only a mechanism for regulating the distance between carbons to render it commercially applicable. This would undoubtedly have been invented had there been a satisfactory source of current. Davy's experiment was repeated from time to time, and the mechanism referred to was finally produced in 1845. In the early sixties practical use was made of the arc lamp, and a short length of street in Paris was lighted by a singular form known as the Jablochhoff candle. It con-

sisted of a parallel pair of carbons separated by an insulating material, the arc forming across the latter between carbon tips. After this the development was rapid, and lamps were brought out by *Prof. Moses G. Farmer* (Dover, N. H., Salem, Mass., Newport, R. I., 1820-1893), and *Charles F. Brush* (Cleveland, Ohio, 1849-date), and others in this country and abroad. The arcs referred to were all open to the air.

In 1889 *L. B. Marks* perfected an inclosing globe for the arc by means of which the consumption of carbon was greatly reduced. The saving resulted from the partial exclusion of air from the globe which became filled with inert gas. The inclosed lamp is now in general use. Still more recently the efficiency of the arc has been increased by impregnating the carbons with calcium, strontium and other luminous substances. The lamps employing this principle are the so-called "flaming" arc lamps of Blondel, Bremer and others. Dr. C. P. Steinmetz has also brought out a very efficient arc lamp in which magnetite and copper take the place of carbons. In this as well as in the other "flaming arcs" the main source of light is the arc, while in the carbon lamps it is the incandescent carbon tips.

Recent Improvements in Electric Lamps. In addition to the forms of arc and incandescent lamp, there are several of recent development which have great commercial promise. In the vacuum tube and mercury arc luminosity comes from the passage of the current through tubes containing respectively air or other gas at low pressure and mercury vapor. The Nernst lamp with its kaolin filament in air is now in general use. In this type an important property possessed by certain refractory earths is utilized. When these are heated they become conductors, and their refractory nature permits the use of very high temperature in air.

Electric Heating. Electric lighting is largely a matter of heat production, but there are also some applications of electric heating in which light is not produced. It is difficult to determine the period in which the current was used for heating purposes, but undoubtedly it was so used early in the nineteenth century. At the present time heat is produced electrically to some extent for cooking, soldering, room and car warming and for metallurgical purposes. An example of the last mentioned is found in the manufacture of the abrasive, carborundum, mentioned in the Introduction.

Engineering Electro-Chemistry ; Early Experiments in Electro-Decomposition. Some slight use was made of electricity in the latter part of the eighteenth century in producing chemical reactions by means of the discharge from Leyden jars and electrical machines. When Volta, by means of his battery, rendered available the electric current, a new impetus was given to discovery in electro-chemistry. Ammonia, nitric acid and sulphuric acid were decomposed, and the plating of one metal with another was accomplished. As had already been mentioned, Davy made use of these processes in 1807. He produced potassium and sodium by electrolysis. Faraday, as a result of his electrical investigations, determined some of the most important laws of electrolysis, which now bear his name. He determined the electro-chemical equivalents of many substances. These researches made possible the commercial advances in electrolysis in recent years, the most important of which from the engineering standpoint are the storage battery and the reduction of metals.

The Storage Battery. The modern storage battery dates from about 1860 when *Gaston Planté* produced spongy lead and lead oxide sheets by the action of the current. This he accomplished by charging and discharging in alternate direc-

tions a cell made up of sheets of lead alternately connected in parallel. Twenty years later, *Camille Faure* improved upon *Plante's* discovery by making the plates in the form of lead grids with fillings of red oxide of lead. The lead oxide was reduced to spongy lead by the current, or further oxidized to peroxide, thus forming the negative and positive plates respectively. This invention made it possible to store a large amount of energy in a small space. Since 1880 the improvements in the storage cells have been largely mechanical ones. In the past few years there has been a tendency to return to the *Plante* type of plate for the positives, and the modern cells are of this form.

Copper Refining and Plating. The electrolytic refining of copper dates back to *Prof. Antoine Ceser Becquerel* (Paris, France, 1788-1878), who in the year 1836 succeeded in producing copper from a solution. It was not, however, until 1865 that *James B. Elkington* made the process a commercial success. The several processes developed since that time differ largely in the manner of handling the ore, which in all cases must be reduced to metallic form before it can be subjected to electrolysis. The use of a copper coating for reproducing the form of objects was one of the first applications of *Becquerel's* discovery.

Other Processes. The reduction of aluminum is of comparatively recent invention, and the principal process in use is that due to *Charles M. Hall* (Niagara Falls, N.Y., 1863-date). In the *Hall* process the aluminum is reduced from oxides while suspended in a bath of fused cryolite. This process was put into commercial operation in 1887. Numerous other electro-chemical processes are in use for producing all kinds of chemical substances, most of these being of comparatively recent invention.

Electric Power Generation and Transmission ; Early Direct Power Generators. The Faraday disk and Barlow wheel contained the essentials of the modern generator and motor. Progress in their development was slow, and for forty years after Faraday's discoveries the primary battery remained the principal source of current supply. The first "dynamos" comprised permanent magnet fields with bobbins of wire moving in relation to them. *Hypolyte Pixii* of Paris, France, in 1832 made such a dynamo with rotating horse shoe magnets. This was improved by Clarke of London, who studied the proper proportions to produce the best effect. *C. G. Page* (Washington, D.C., 1812-1868) further modified the machine by moving a soft iron armature before permanent magnet fields on which coils of wire were wound. The changes in the field produced by the movement of the soft iron armature induced electromotive force in the coils. Other inventors introduced improvements one by one, increasing the size of the machines gradually. In 1856 an improved armature by *Werner Siemens* (Berlin, Germany, 1818-1892), and the result was a more rapid development. Siemens' armature consisted of a cylinder with deep slots on opposite sides in which the coils were wound. It was the forerunner of the modern drum armature. In 1860 an Italian inventor, *Paccinotti*, produced a type of armature in which the coils were wound around the surface of a ring.

The early generators employed permanent magnet fields which were too weak for power generation on a large scale. While battery current was available for field excitation this was not convenient. Hence the importance of the introduction of the auxiliary magneto-generator exciter by Wilde in the early sixties. Sir Charles Wheatstone made the final step in this direction by exciting the field from the armature of the machine, exhibiting his invention in 1867.

Paccinotti did not develop his ring armature, and it was not until 1870 that Gramme, a manufacturer in Paris, produced the modern ring type. One of the first reproductions of the Gramme machine in America was constructed by Professors Anthony and Moler at Cornell in 1875, and the machine was exhibited at the Centennial Exposition of 1876. A number of interesting features were introduced, among which was the movable rocker arm for the brushes.

The invention of Gramme, combined with those immediately preceding it, resulted in the production of satisfactory electric generators and aroused the interest of a number of practical inventors, among whom, in addition to those already mentioned, the most prominent were *Brush*, *Weston* and *Edison*.

Early Alternators. Practically all of the machines mentioned were direct current generators. The apparatus for which current was required, had been constructed to operate from primary batteries, hence there was no demand for the alternating current. All of the machines required commutating or rectifying devices for reversing the connection of the various coils with the circuit as the current in the coils alternated. Inherently the machines were alternators with the exception of the Faraday disk, which in its original form was of no particular use. It is surprising, therefore, that the adoption of alternating current was delayed until the early eighties. The slow development of the alternating current generator was partly due to the fact that the early machines of this type were limited in output, and the use of a separate exciter was considered troublesome. As stated before, the apparatus that had been developed was not suited to the alternating current, and the use of the alternating current was little understood. Its use did not become popular until the invention of the transformer for raising the pressure, and by the use of which

transmission efficiency was greatly improved. The first commercial alternators were built for use in connection with the Jablochhoff arc lamps which consisted of two vertical parallel carbons. Alternating current was desirable with these in order to burn off the terminals evenly. These machines were built by Gramme between 1876 and 1880. They contained internal revolving field magnets supplied with current by a direct connected exciter. A few years before this there were several magneto-alternators operating arc lamps in light-houses and built by l'Alliance Francaise, but they were of very small capacity. Among builders of alternators of this same period *Prof. Gisbert Kapp* was one of the most prominent. The magnetic field of Kapp's alternator comprised sets of bobbins placed opposite the two faces of a ring armature. His machine was very successful. Other alternator builders of the time in Europe were *de Meritens*, *Friederick von Hefner Alteneck*, *Ganz*, *Schuckert*, *Zipernowski*, *Deri*, *Mordey*, *Z. de Ferranti*, and others. In the United States the pioneer was *George Westinghouse*, who was constructing alternators of small size in 1886-1887.

The Transformer. The early alternators were of the low pressure type with limited range of transmission. The invention of the transformer, the principle of which had been discovered by Faraday in 1831, was made in England by *Messrs. Gaulard* and *Gibbs* in 1882 and 1883. Their transformer was practically the same as Faraday's ring, but in order to prevent the leakage of magnetism between the coils these were placed close together. *Zipernowski* and *Deri* in 1884-85 built these transformers in large sizes. At the same time Westinghouse secured the American rights of the Gaulard and Gibbs patents and proceeded to develop the alternating current in this country. In spite of opposition it was gradually intro-

duced, first for incandescent lighting, then for power transmission, later for arc lighting and motor service. The many inventors at work on the transformer have produced various mechanical and electrical improvements chiefly dealing with increase in efficiency, strengthening of insulation and reduction of magnetic leakage.

Power Transmission. The production of successful alternators and transformers opened the way for power transmission over considerable distances. During the winter of 1890 a transmission plant was installed at Telluride, Colo., employing Westinghouse single-phase alternators of 100 horse power, the largest then made. The motor and generator were alike except that the latter was self-exciting while the former was separately excited. The transmission pressure was 3000 volts and the distance, 2.6 miles. Shortly before this, the polyphase current had been developed, but had not been applied to power transmission up to 1890. In 1888 *Professor Ferraris, Nikola Tesla, and M. Dolivo von Dobrowolski* had adapted the principle underlying Arago's disk experiment to the production of mechanical power without the aid of a commutator. By means of two or more alternating currents with maximum values occurring at different times they produced a rotating magnetic field with fixed coils. A short circuited armature placed in such a rotating field had a tendency to follow its motion. The Tesla patents were acquired in this country by the Westinghouse Company in 1888, and polyphase *induction motors*, as they were called, were soon upon the market. *Mr. C. E. L. Brown* of the Oerlikon Machine Works took up the development of the single-phase system and operated a transmission plant at Kassel, Germany, over five miles in length. Two one-hundred horse power generators operating in parallel were employed, and current was

transmitted at 2000 volts. In order to demonstrate the possibility of long distance transmission a famous experiment was made in connection with the Frankfort Exposition of 1891. Three-phase current was used to transmit power from Lauffen, a distance of 75 miles, and a special generator was designed by Brown to produce the three-phase current at 50 volts. The pressure was raised to 13,000 volts for transmission, by means of special transformers. Power was generated by a water turbine at Lauffen and transmitted to the Exposition; where it was retransformed into mechanical power. The efficiency of transmission was about 75 per cent, which was so satisfactory that a great impetus was given to the application of the polyphase transmission system. Professor Elihu Thomson thus summarized the status of power transmission at this period.

“ These long distance power transmission plants are generally spoken of as ‘ two-phase ’ or ‘ poly-phase ’ systems. Before 1890 no such plants existed. A large number of small installations are now working over distances of a few miles up to 100 miles. They differ from what are known as single-phase alternating systems in employing, instead of a single alternating current, two, three, or more, which are sent over separate lines, and in which the electric impulses are not simultaneous, but follow each other in regular succession, overlapping each other’s dead points, so to speak. Early suggestions of such a plan about 1880, and thereafter, by Bailey, Deprez and others, bore no fruit, and not until Tesla’s announcement of his poly-phase system in 1888 was much attention given to the subject. A wide-spread interest in Tesla’s experiment was invoked, but several years elapsed before engineering difficulties were overcome. This work was done mainly by technical staffs of the large manufacturing companies, and it was necessary to be done before any notable power transmission on the polyphase



system could be established. After 1892 the growth became very rapid." *

After the successful Lauffen-Frankfort experiments numerous power projects were begun, the most ambitious of which involved the distribution of power from Niagara Falls. In 1893 the Westinghouse Company, was awarded the contract for a 15,000 horse-power plant to develop two-phase currents at 2000 volts. This plant was successfully built and has since been extended by the Niagara Power Company, which at the present time has three large power plants with a combined ultimate capacity of nearly a quarter million horse power. Since 1890 numerous water powers in all parts of the world have been developed and are being developed by means of the polyphase current, and power may now be transmitted as far as economic conditions warrant.

Early Electric Motors. An essential feature of power transmission is the electric motor. The motor began with Barlow's wheel in 1824. In this form it did not permit of the production of any considerable amount of power, and it was not until after the invention of the electro-magnet that the motor was used commercially. *Moritz Hermann Jacobi* (St. Petersburg, 1801-1874) combined a number of electro-magnets in such a way as to permit the development of considerable power. A number of electro-magnets were arranged as shown in Fig. 18. Current was supplied intermittently through contact rings to the revolving armature. In this way it received a series of impulses in one direction. This motor was placed on a boat on the river Neva, Russia. *Thomas Davenport* was the builder of the first motor in the United States. In 1837 he was able to construct a combination of permanent and electro-magnets very similar in principle to

* Electrical World, Vol. 38, p. 881.

that of Jacobi. Professor Henry also built a powerful motor, using his own electro-magnets. Numerous experimenters, including Fromant, Professor Farmer, Paccinotti, and others gradually improved the motor until it was taken up commercially by the builders of dynamos and developed in con-

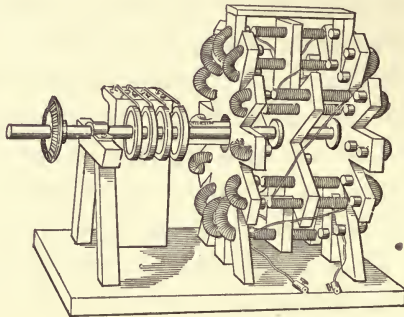

FIG. 18. One of the earliest electric motors. Installed by Jacobi on boat on River Neva, Russia, in 1838.

junction with them. As practically all of the dynamos were reversible they made fairly good motors.

Recent Electric Motors. The electric motors of the present time are of several different types, their peculiar forms having been forced upon them by the conditions under which they are required to operate or by the available source of current. The first motors were simply reversed dynamos. When motive power was required for traction purposes it was found that reversed dynamos were not satisfactory. Then began the evolution of a motor peculiarly suited for this work, and the modern series street railway type is the result. For this purpose large starting torque, reversibility and durability were the prime requisites. For stationary uses the shunt motor was developed as constant speed was found to be important. The

increase in the use of alternating current from 1882 onward required the development of alternating current motors. Single or polyphase alternators when operated as motors were fairly satisfactory. Thus operated the alternator is known as a synchronous motor from the fact that it maintains a speed proportional to that of the generator. Professor Thomson in 1887 produced rotation of a single-phase motor in which the current was furnished to the field and the armature was short circuited. The name "*repulsion motor*" was given to this type. It was not at the time commercially successful, but has recently received great attention. As previously stated, the invention of the rotating field by Tesla and Ferraris made available a new type, the induction motor, so-called from the fact that there was no electrical connection between the field and the armature. The motor has been mechanically and electrically improved until at the present time it is practically perfect. Induction motors are being built in sizes up to 6000 horse-power. Synchronous motors are built in as large sizes as are demanded.

The latest of all alternating current motors is the series type which has been successfully adapted to the requirements of railway service. Satisfactory motors are now obtainable for operation under practically any conditions of service and with any kind of power supply.

Electric Traction. As soon as the electric motor had been made possible by the discoveries of Oersted, Faraday, Barlow and Henry, crude forms were developed experimentally. The first and most natural application of the motor was to transportation. In 1834 a small model of a railway car driven by current from a primary battery was constructed by *Thomas Davenport*, a blacksmith of Brandon, Vt. Four years later *Robert Davidson* of Aberdeen, Scotland, constructed a loco-

motive equipped with a Jacobi motor which was tried on the Edinburgh-Glasgow Railway. *Prof. Moses G. Farmer*, in 1847, built and operated a car of small size, and in 1850 *Thomas Hall* built a reversible car in Boston.

The first electric railway experiment on a large scale was conducted by *Professor Page* of the Smithsonian Institution. A locomotive supplied with current by a large Grove battery was operated in 1857, and but for the troubles with the battery would have been considered very successful for the time. All of these early experimenters were handicapped by the lack of an ample supply of electrical power. It was, therefore, not until after the development of the electric generator that they were commercially successful.

In 1875 experimental railway work was taken up again by *George F. Green* of Kalamazoo, Mich., who built a small equipment that was supplied with battery current, although the dynamo was then partially developed. In 1879 at the Berlin Exposition a model road constructed about the Exposition grounds was the first to carry passengers commercially. It was constructed by *Siemens* and *Halske*,* who had by this time developed a satisfactory motor and generator. This experimental line was followed by a commercial road, built by the same company at Lichterfeld, near Berlin, in 1881. The car used attained high speed and was continued for a long time in regular service. These successful experiments gave a great impetus to the electric railway, and numerous inventors devoted their attention to the subject. In addition to those already mentioned, *Stephen D. Field* and *Thomas A. Edison* constructed an electric locomotive under their own patents and exhibited it in Chicago in 1883. At this time *Frank J. Sprague*, then a midshipman in the United States Navy,

* The firm founded largely by Werner Siemens and his brother was a pioneer in all branches of electrical work.

became interested in electric railway work and was a pioneer in the movement. *Charles J. Van de Poelle* constructed a small experimental line in Chicago, in 1882-83, in which the current was supplied from an overhead wire. In the following year Van de Poelle operated cars at the Toronto Exposition and soon after in other places.

Commercial Application. By the year 1885 the electric railway was approaching commercial success. It was being shown at all the expositions, and cars were in commercial

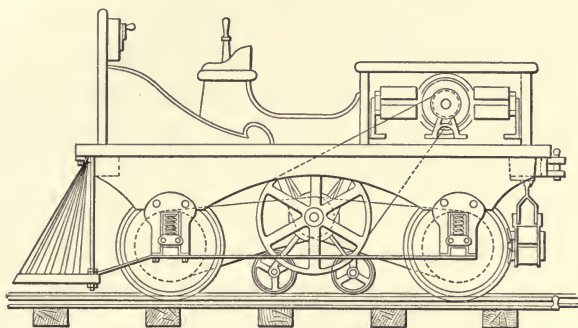

FIG. 19. Early electric locomotive, the Ampere.

operation abroad. *Mr. Leo Daft* had constructed a locomotive of considerable power which he named the "Ampere," and he also had other cars in operation. In this year electric locomotives were put into operation on the Hampton branch of the Baltimore Union Passenger Railway Company, and pulled regular street cars. During the same year Daft operated a locomotive, the "Benjamin Franklin," on the Ninth Avenue Elevated Road in New York City. Experiments at practically the same time were being carried on in Cleveland, Ohio, by Messrs. *Bentley* and *Knight* who installed an unsuccessful underground conduit. Among the experimenters

of this time may be mentioned *Dr. Wellington Adams, J. C. Henry, Sidney H. Short*, and others. In the meantime Mr. Sprague had not been idle, and in the year 1885 construction work was begun on the Thirty-fourth Street branch of the New York Elevated Road, and a year later an elevated car was operated. The experience gained here was applied in 1887 to the construction of roads at St. Joseph, Mo., and Richmond, Va. These were the first to be electrified on a large scale. Mr. Sprague thus summarizes the features of this now historic system: "A system of distribution by an overhead line carried over the center of the track, reinforced by a continuous main conductor, in turn supplied at central distributing points by feeders from a constant potential plant, operated at about 450 volts, with reinforced track return. The current was taken from the overhead line at first by fixed upper pressure contacts, and subsequently by a wheel carried on a pole supported over the center of the car and having free up and down reversible movement. Exposed motors, one to each, were centered on the axles, and geared to them at first by single, and then by double reduction gears, the outer ends being spring supported from the car body so that the motors were individually free to follow every variation of axle movement, and yet maintain at all times a yielding touch upon the gears in absolute parallelism. All the weight of the car was available for traction, and the cars could be operated in either direction from either end of the car. The controlling system was at first by graded resistances, afterward by variation of the field coils from series to multiple relations, and series-parallel control of armatures by a separate switch. Motors were run in both directions with fixed brushes, at first laminated ones placed at an angle, and later solid metallic ones with radial bearing." *

* Transactions International Electrical Congress, Vol. III, p. 331.

Recent Developments. Since 1887 the improvements have been largely those of electrical and mechanical design as far as motors are concerned. As the range of operation of the cars increased and electricity was applied to heavy traction work other improvements were necessary. Among these may be mentioned a system of multiple unit control for starting the motors of the several cars of the train at the same time. This was also invented by Sprague. The interurban development brought about the use of alternating current transmission for the power and the introduction of substations in which the current was transformed to direct for use upon the cars. At the present time the alternating current motor is in process of application to electric traction and is rendering unnecessary the special substations. The steam railroads of the country are also seriously considering the adoption of electricity as motive power, especially for suburban traffic and tunnel service.

Volta's cells, 1793.			
Davy's discovery of electro decomposition, 1807.	Davy's electric lights, 1802-1807.		Du Fay, discoveries in conductors and insulators, 1733.
Bequerel, copper decomposition, 1836.	Starr (1845) patented incandescent lamps.	Wheatstone and others, needle telegraph, 1832.	Oersted, Ampère, Arago, Barlow, Faraday, Henry, Sturgeon, electro-magnetic devices, 1826-1832.
		Morse printing telegraph, about 1832.	Pixii, Page, Clarke, and others, early forms of generator, 1832-1860.
Planté, lead storage batteries, 1860.	Farmer, Brush, lamp mechanism.	Edison duplex and quadruplex, 1872.	Jacobi placed motor on boat, 1834.
Elkington, copper refining, 1865.	Jablochkoff candle, Paris, early sixties.	Bell telephone receiver, 1876.	Davenport, Henry, Fromant, Farmer, Pacinotti and others built motors, 1835-60.
Farré, plated battery plates 1860.	Edison, (1879) Swan, practical incandescent lamps.		Siemens' improved armature, 1856.
		Gray, Berliner, Hughes, Edison, Huggings, Blake, telephone transmitters, various dates, 1880-1890.	Paccinotti, ring armature, 1860.
			Wheatstone, self-excitation, 1867.
			Gramme (Anthony & Moler), modern ring armature, 1870.
			L'Alliance Française, Gramme, early alternators, before 1880.
			Kapp, Westinghouse and others, improvements in alternators, 1880 to date.
			Brush, Edison, Westinghouse and others, improvements in d. c. generator design and construction, 1870-1890.
			Gaulard and Gibbs, the transformer, 1882.
Hall, Cowles, aluminum, reduction, 1887.	L. B. Marks, inclosing globe.		Zipernowski, Deri, and others, improvements in transformers, 1884-1885.
			Thomson, repulsion motor, 1887.
			Ferraris, Tesla, Dobrowski, Brown and others, induction motor, 1888-1891.
			Telluride transmission of power, single-phase, 1890.
			Brown, Westinghouse and others, developed a. c. single-phase motors, about 1890.
			Long distance transmission of power at Frankfurt, polyphase, 1891.
			Niagara Falls power development, 1893.
			Recent developments include many transmission lines, some over 150 miles in length.
Recent developments include electrolytic manufacture of many compounds.	Recent inventions, metallized carbon filament, incandescent lamps.	Hertz, followed by Marconi, De Forest, and others, wireless telegraph.	Recent developments include heavy locomotives, a. c. motors and better power transmission.
	Recent inventions, Blondel, Bremer and others, flaming arc, and Steinmetz, magnetic arc.	Recent inventions, improved switchboard facilities, possible wireless telephony.	

CHAPTER II.

FUNDAMENTAL ELECTRICAL AND MAGNETIC QUANTITIES.

OUTLINE.

The Faraday disk arranged for experiments to be used as the basis of definitions.

Experiments showing the inter-relation of fundamental electrical and magnetic quantities.

Effect of change of direction of current and field.

Mechanical reaction between current and field.

Resistance and electromotive force, Ohm's Law.

Generator of e. m. f. by motion of conductor in field.

Electrical power.

Identity of electrical and mechanical power.

Summary of deduction from experiments.

Definition of units in the practical system.

Fundamental units — current — resistance — e. m. f. — derived unit — power — energy — quantity — inductance — capacity — field strength.

Definition of units in the C. G. S. system.

Field strength — e. m. f. — current — quantity — power — energy — resistance — capacity.

Summary of definitions.

THE study of electrical engineering should be based upon accurate conceptions of fundamental electrical and magnetic quantities which for practical use must be reduced to definitions in previously familiar terms. Such definitions are only possible when the fundamental facts are clearly understood. To avoid unnecessary complication, a few very simple and familiar experiments have been selected as the basis of the definitions. Faraday's experiment with the magnet and pivoted disk used as a generator of electric current, and Barlow's experiment, using a similar apparatus as a motor, illustrate the intimate relation which exists between magnetism and the electric current. With this apparatus in modified

form a number of instructive experiments may be performed. For mechanical convenience the apparatus has been arranged as shown in Fig. 20. A large compound permanent magnet, with its poles brought close together to form a short air gap, and consequently a strong magnetic field, is mounted in the position shown. The surfaces of the poles have been made

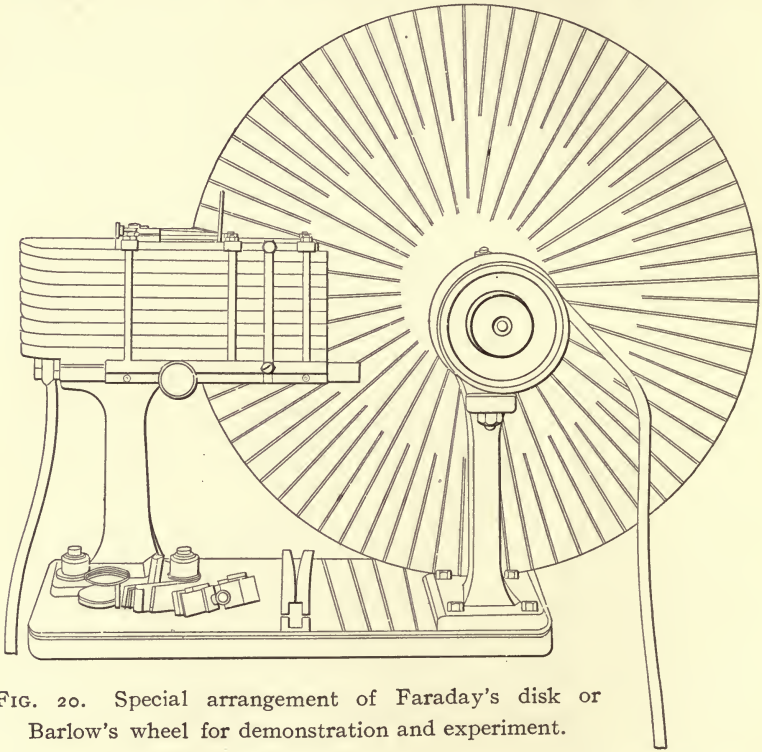

FIG. 20. Special arrangement of Faraday's disk or Barlow's wheel for demonstration and experiment.

large enough to produce an air gap area of several square inches. A large copper disk, rotating in ball bearings, is so placed that it cuts the magnetic field at as high a velocity as possible. Current is conducted to and from the disk through copper strips or "brushes" which bear upon the center and rim. Radial slots are cut in the disk in order to confine the current

to a direct path between the brushes. The magnet is movable with respect to the disk, and the disk itself may be removed and replaced by another. A pulley is mounted upon the disk axle for the purposes of supplying power when the disk is operated as a generator and of connecting it to a load when it is used as a motor. In this machine the current flows from brush to brush through the disk and passes through the magnetic field. The apparatus embodies the most important principles of modern electric generators and motors, but it is not efficient as a machine in the form shown. It has, however, a modern prototype in the unipolar dynamo which differs from it only in details of design and construction. On account of the recent development of the steam turbine, giving high peripheral velocity, the unipolar dynamo is coming into commercial operation.

Experiments Showing the Inter-relation of Fundamental Electrical and Magnetic Quantities.

Experiment I. When current is sent through the disk from center to rim, it rotates in a definite direction. If the direction of the current is reversed and it flows from rim to center, the disk rotates in the opposite direction. Further, if the magnetic poles are reversed, the direction of the current remaining the same, the direction of rotation is reversed. In

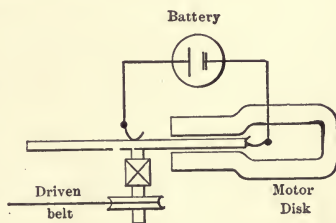

FIG. 21. Diagram showing connection of battery and disk, latter acting as motor.

other words, reversing both the magnet and the direction of the current at the same time does not change the direction of rotation. The conclusion from these experimental facts is

that *there is a reactive force between a current and a magnetic field, which has a definite direction with relation to them.*

Experiment II. In the first experiment the effects of changing the direction of current and field were noted. The investigation may be carried farther by substituting for the first disk another of different thickness or one made of different material. The rotative force will be greater or less, indicating a change in the current, the field being assumed to remain constant. It is convenient to say that if the field is the same *the mechanical force is an indication of the strength of the current.* Similarly if a stronger magnet replace the original one the rotative force will be increased. In this case, assuming the current to have remained constant, *the force may be regarded as an indication of the strength of the field.*

Taken together, Experiments I and II give a means for determining the *relative* values of current and field strength.

Experiment III. Having from Experiments I and II a convenient means for determining the relative strength of two or more currents, a study of some of the properties of the electric circuit may be made. In Experiment II a change in the dimensions or material of the disk through which the current passes was found to alter the force, indicating a change in the current. There was evidently a change in the *resistance* offered by the disk to the flow of the current. If this current was furnished by a cell of primary or secondary battery there must have been in this cell a *property* or *condition* by which it maintained the current. This ability to maintain the current is termed the *electromotive force*, a cumbersome but expressive name. Instead of changing the disks, a different source of electromotive force may be used. If two cells in series be employed instead of one, an increased rotative force will be evident, indicating an increase in the current. Taken

together Experiments II and III show that changing the dimensions or material of a circuit alters the resistance, and that *increasing the electromotive force with the same resistance increases the current*. The inter-relation of current, electromotive force, and resistance has been experimentally determined and is known as *Ohm's Law*. This law states that *the current is directly proportional to the electromotive force, and inversely proportional to the resistance in a circuit*.

Experiment IV. If the rims and centers of two Faraday disks are connected by electrical conductors, and if one of these disks be rotated by an external source of power, the other will tend to rotate also. *This tendency indicates the flow of a current through the motor disk, the connecting circuit, and therefore through the generator disk, as all electrical circuits must be continuous. The current in the motor disk is maintained by an electromotive force produced by the motion of the generator disk in its field.* A change in the speed of the generator disk will correspondingly change the current in the circuit, indicating a similar change in the electromotive force. If while

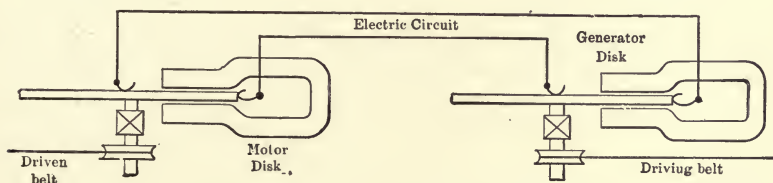

FIG. 22. Diagram showing two disks connected electrically, one of which acts as generator, the other as motor.

the speed of the generator disk remains unchanged, a stronger or weaker magnet replaces the original one, an increase or decrease of electromotive force will result. These experimental facts lead to the conclusion that *the electromotive force depends both upon the speed of rotation of the disk and the strength*

of the field. Experiment shows it to be directly proportional to either speed or field strength and therefore to their product.

Experiment V. In the generator disk of Experiment IV the electromotive force produces a current which obviously *must have reacted upon the generator field* with a mechanical force, just as in the case of the motor disk. The mechanical force is proportional to the current, and the electromotive force which sets up this current is proportional to the speed, *therefore the product of current and electromotive force in any system of electrical units is equal to the product of velocity and force in any system of mechanical units.* As the product of force and velocity is mechanical power, the product of electromotive force and current must be electrical power. With systems of units chosen for the electrical and mechanical quantities, the connecting factors may be experimentally determined.

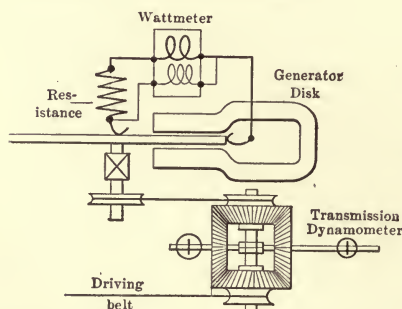

FIG. 23. Diagram showing generator disk driven through differential transmission dynamometer to measure mechanical power input.

For example, if in the driving belt of the generator disk a transmission dynamometer be inserted, the net tension in the belt may be determined. The belt velocity may be measured by a speed indicator. The product of the tension and the velocity will give the mechanical power. For the corresponding electrical quantities, experiments, embodying the principles indicated in Experiments I to IV, may be used to determine the values of current and electromotive force. After correcting for the losses in the generator, the mechanical input may be equaled to the electrical output. *These experiments establish the identity of mechanical and electrical power.*

Experiment VI. As a further illustration of the interchangeability of mechanical and electrical power, two Faraday disks may be belted together as shown in Fig. 24. They are also connected electrically as before. When once brought up to speed the motor-generator set would continue to rotate if there were no losses. There are, however, mechanical and electrical losses throughout the system which must be supplied from an external mechanical or electrical source. A small auxiliary motor may be used to supply the lost power

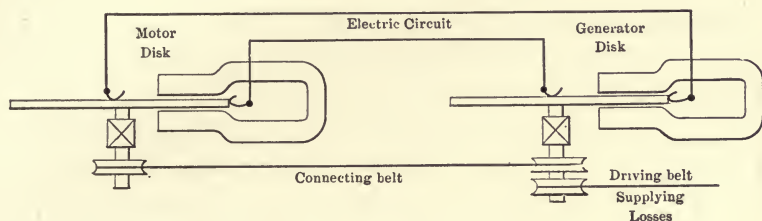

FIG. 24. Diagram showing two disks electrically and mechanically connected with auxiliary belt for supplying losses.

mechanically, or a battery or other source of electrical supply may do the same through the electric circuit. Except for these losses *the mechanical power passing through the belt from motor to generator will be equal to that electrically transmitted from generator to motor.*

Taken together Experiments III and V lead to a most important and useful deduction. Experiment V shows that electrical power is the product of electromotive force and current. From Experiment III electromotive force was seen to be the product of resistance and current in a circuit containing resistance only. In such a circuit, therefore, *the power used in overcoming the electrical resistance is the product of the square of the current and the resistance.* This deduction is known as *Joule's Law.*

Summary of Deductions from Experiments I to VI.

Experiment I shows the existence of a mechanical reaction between the current and a magnetic field, and this reaction has a definite direction with respect to either the field or the current.

Experiment II shows the relation of the mechanical reaction to the magnitude of the field and the current, and furnishes the basis for the definition of one in terms of the other.

Experiment III shows the inter-relation of current, electromotive force, and resistance, which is embodied in Ohm's law.

Experiment IV shows the inter-relation of field strength, speed, and electromotive force, and furnishes a basis upon which one of these may be defined in terms of the other two.

Experiments V and VI show the identity of mechanical and electrical power.

Experiments III and V furnish a basis for determining the rate at which power is transformed into heat in resistance, the statement of which is known as Joule's Law.

The apparatus used in these experiments forms a very crude generator or motor. The losses are, therefore, exceptionally large. The student should not judge of the efficiency of modern machines by reference to the Faraday disk.

Definitions of Units in the Practical System.

The experiments described have indicated the inter-relations existing among mechanical and electrical quantities. If two of the latter be fixed in any way all will then have absolute values, which may be determined by the relations already established. From the standpoint of mathematical and physical science the most logical units to define first are those of electromotive force and current. For practical purposes, however, legal standards of resistance and current have been established as being most readily reproduced in tangible

form. The legal standards are secondary standards, absolute measurements of the fundamental electrical quantities, being troublesome and expensive to make. For the present purposes it is sufficient to define these legal standards.

Fundamental Units.

Unit of Current. The legal or international *ampere* is the current which will deposit 0.001118 gramme of silver per second from a solution of 15 parts by weight of silver nitrate in 85 parts by weight of water. In the instructions for making these measurements, specifications are given as to the details of dimensions of the platinum bowl which forms the *kathode* or exit of the current, and the silver plate which forms the *anode* at which the current enters. The specifications also include the method of covering the anode with filter paper for the purpose of retaining any loose particles.

Unit of Resistance. The legal or international *ohm* is that represented by the resistance offered to an unvarying electrical current by a column of mercury at the temperature of melting ice and having a mass of 14.4521 grammes. This column has a constant cross-sectional area and a length of 106.3 centimeters.

Unit of Electromotive Force. The legal or international *volt* is the product of the corresponding ampere and ohm, that is, it is the electromotive force necessary to maintain an ampere against a resistance of an ohm.

Problems Illustrating the Use of the Units of Current Resistance and e. m. f.

The electric heaters on a street car draw five amperes at a trolley pressure of 550 volts. There are four heaters in series. What is the resistance of each? *Ans.* 27.5 ohms.

The hot resistance of the field coil of a shunt dynamo is 10 ohms. How much current is it drawing when the machine is generating 220 volts?

Ans. 22 amperes.

When 5 ohms of field resistance are inserted in series with the field coil, the armature pressure drops to 180 volts. What current then flows?

Ans. 12 amperes.

The open circuit e. m. f. of a railway storage battery is 580 volts. When 500 amperes are drawn from it the e. m. f. falls to 540 volts. What is the resistance of the battery?

Ans. 0.08 ohm.

A trolley car draws 100 amperes from a power station through a trolley line and track resistance of 0.5 ohm. What is the e. m. f. at the car when the station pressure is 550 volts?

Ans. 500 volts.

With the primary units established, and using the experimental relations already established, the remaining electrical units may be readily defined.

Derived Units. The apparatus used in Experiments I to VI is useful in determining the general relations existing among the various quantities, but it does not give sufficiently accurate results for scientific purposes. The current in flowing from brush to brush does not flow through a very definite path. Having established the general relations, however, with this apparatus, the current may now be considered as confined to a particular path as shown in Fig. 25.

In a conductor as shown, generating electromotive force by motion in the field or producing mechanical force by virtue of the current in the conductor, the relations of the various

quantities are perfectly definite. The remaining electrical quantities are then as follows:

Unit of Electrical Power. Experiment IV shows that electrical power is the product of electromotive force and current. It follows that the unit of electrical power is the product of the units of electromotive force and current, or the *volt-ampere*. The name given to this unit is the *watt*. The watt is a rather small unit for practical purposes, and

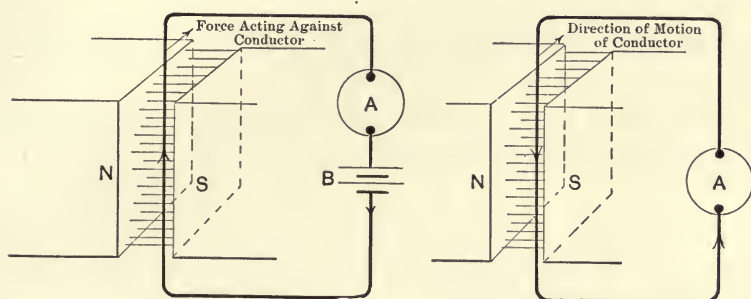

FIG. 25. Diagram showing circuit, confining current to a definite path and located in a magnetic field.

one thousand times (1000) the watt or the *kilowatt* is the ordinary commercial unit.

Experiment has shown that a mechanical horsepower is the equivalent of approximately 746 electrical watts, so that the term *electrical horsepower* is frequently applied to this number of watts. The electrical horsepower is, therefore, somewhat less than three-fourths of a kilowatt.

Unit of Electrical Energy. Energy is the product of power and time, so that the unit of electrical energy is the *volt-ampere-second*, or the *watt-second*, which is for convenience given the name *joule*. The joule is a very small unit of energy, and it is very seldom used in practice. The more common units are the *watt-hour* or *kilowatt-hour*, and occasionally the

term *electrical horsepower hour* or even *electrical horsepower year* is used.

Unit of Electrical Quantity. The quantity of electricity which is passed through a circuit is the product of the current and the time. One ampere flowing for one second is the unit, and this ampere-second is given the name *coulomb*. The coulomb is not a convenient unit for practical purposes, the ampere-hour being the one usually employed.

Problems Illustrating the Units of Power, Energy, and Quantity.

How much power is being used in the car heaters which draw five amperes at 550 volts?

Ans. 2.75 K.W.

If an electric motor is delivering 5 horsepower at an efficiency of 80 per cent, what current is it drawing from a 220-volt line?

Ans. 21.2 amperes.

A residence contains 25 incandescent lamps which operate an average of 20 hours per month. Each lamp takes 0.6 ampere at 110 volts. What is the monthly bill at 11 cents per K. W. hour?

Ans. \$3.63.

A 20-ton trolley car uses 0.18 K.W. hours per ton-mile. What is the average current with a trolley line pressure of 525 volts when the car speed averages 15 miles per hour?

Ans. 102.9 amperes.

A railway storage battery is discharged at a rate of 1100 amperes for eleven minutes. How many ampere-hours has it given out? How many coulombs?

Ans. 201.7 ampere-hours.

726,000 coulombs.

How many days will a 10-volt gravity battery continue to yield one-tenth ampere if its ultimate output is ten K.W. hours?

Ans. 416.6 days.

Unit of Inductance. There are two properties of an electric circuit which are sometimes of the very greatest importance. One electrical property has been already defined as resistance. Electrical resistance is closely analogous to mechanical resistance, for both produce a dissipation of power as heat. In mechanics there are two other quantities, known as *inertia* and *elasticity*, which at times produce important effects. The analogs of these in an electric circuit are given the names *inductance* and *capacity*.

Inductance is that property of an electric circuit by which it



FIG. 26. Diagrams drawn by Faraday showing the magnetic field surrounding one and two conductors carrying current. The particles represent iron filings.

resists a change in the current, just as inertia is that mechanical property by which a mass resists a change in velocity. The cause of inductance in an electric circuit is the magnetic field which surrounds the conductors. Professor Oersted discovered that a conductor is surrounded by a magnetic field, which field varies with the current. From what has been shown in the experiments with the Faraday disk, an electro-

motive force is produced in a conductor when it is cut by a magnetic field.

When the current in a circuit is changed, this magnetic field changes correspondingly, and in effect cuts the conductor, producing an electromotive force in it. This electromotive force has such a direction as to resist the *change* in current; in other words, the electromotive force tends to maintain the current at its previous value. This is similar to the effect of inertia in a body which produces a reactive force when the velocity is changed, the reactive force always resisting a *change* in velocity. The inductance of a circuit may be conveniently defined in terms of the electromotive force which is produced by a definite rate of change of the current. *When a rate of change of current of one ampere per second produces an electromotive force of one volt, the circuit is said to have a unit of inductance, and the name henry is given to this unit.*

Unit of Capacity. In the apparatus known as an electrical condenser there are plates of conducting material separated by sheets of insulating material or dielectric. When an electromotive force is applied to the terminals of such a condenser a certain quantity of electricity will flow into it until it is "charged" to the same pressure as that of the applied circuit. The process of charging a dielectric consists of setting up an electrical stress in it which is analogous to the mechanical stress produced in a solid or fluid material when deformed under the action of a force. In "charging" a condenser the current will flow into it as long as the pressure at the terminals is increasing. A definite change in the terminal pressure will store a definite quantity of electricity in the condenser. The ability of a condenser to receive this charge is known as its *capacity*. The capacity may be defined either in terms of the quantity of electricity which will be held at

a given pressure, or in terms of the current which will flow into the condenser when the terminal pressure is changing at a definite rate. Either of these definitions will be perfectly accurate, and it is convenient to be familiar with both of them.

The capacity of a condenser, in *farads*, is numerically equal to the quantity of electricity in coulombs which it will "hold" under a pressure of one volt. Defined in another way, *a condenser or other circuit has a capacity of one farad when a rate of change of pressure of one volt per second at the terminals produces a current of one ampere.* While the condenser has been referred to in defining capacity, it should be noted that all circuits have capacity, as they consist of two or more conductors, separated by a dielectric, usually air. The farad, as defined, is an inconveniently large unit of capacity, and one millionth of it, the micro-farad, is the usual practical unit.

Problems Illustrating the Units of Inductance and Capacity.

The current in a circuit is changed from 0 to 100 amperes in 0.005 second. The average counter-e. m. f. is 15 volts. What is the inductance of the circuit?

Ans. 0.75 milli-henry.

How many volts (average e.m.f.) will be required to reverse a current of 50 amperes in a circuit of 5 henrys inductance in 0.5 second?

Ans. 1000 volts.

The e. m. f. in a circuit alternates between 30,000 volts positive and 30,000 volts negative, 60 times per second. What average current (charging current) will flow into the line with the receiver terminals open, if its capacity is 8 micro-farads?

Ans. 28.8 amperes.

An underground cable system draws an average of 0.2 ampere charging current, when the e. m. f. alternates between 3000 volts positive and 3000 volts negative 260 times per second. What is the capacity of the cables?

Ans. 0.128 micro-farad.

The Unit of Magnetic Field Strength or Intensity. From the interaction between current and magnetic field, shown by Experiments I and II, when the unit of current has been defined, that of field strength follows naturally. An additional experiment with the apparatus in Fig. 25 modified by connecting two conductors in series will indicate an additional and almost obvious fact. If two conductors connected in series, and therefore carrying the same current, are located in the same field, the reactive force between current and field will be twice as great as for one conductor. In other words, the force is proportional to the length of the conductor. Similarly the electromotive force produced by the movement of the conductor through the field is proportional to the length of the conductor.

The unit of field strength might then be taken as that which produces a unit of force, say a dyne or a pound, upon an ampere of current in a unit length of conductor. Or it could be that which produces a volt in a unit length of conductor moved at a unit velocity. As a matter of fact, the unit of field strength or intensity in general use is that which produces a dyne of force per centimeter length of conductor upon a current ten times as large as the ampere. This same field intensity produces an electromotive force of $\frac{1}{100,000,000}$ volt in a centimeter length of conductor when the velocity is one centimeter per second.*

A field of this value is said to have an intensity of one *gauss*.

* The reason for the use of these apparently arbitrary constants will be evident after a study of the following section.

Problems Illustrating the Unit of Field Strength.

A motor armature contains 500 feet of active conductor (located in the field) carrying 50 amperes. What is the average field strength when the tangential pull on the armature is 1000 pounds? (Assume 1 lb. = 445,000 dynes.)

Ans. 5840 gausses.

The above machine is operated as a generator. What is the e. m. f. if the conductors are connected in two circuits (250 ft. per circuit) and move at 2430 feet per minute?

Ans. 550 volts.

Definitions of Units in the C. G. S. (Centimeter-Gram-Second) System.

The definitions of the units in the practical system already given were based upon the arbitrary legal standards and upon simple experiments easily reproducible. Underlying this system of units is a much more exact one based upon the reaction of the magnetic field upon a unit pole. A unit pole is by definition one which will react upon a similar pole with a force of one dyne at a distance of one centimeter. Such a pole when placed in a magnetic field gives a means of determining the strength of the field directly in terms of force and distance. It gives, therefore, a theoretically perfect method of definition, as force and distance can be very accurately measured. It is, however, a most difficult and cumbersome method to apply practically. When the unit pole is placed in the field, the force in dynes acting upon it is the strength of the field, or, more accurately, it is its *intensity*.

Fundamental Units.

Magnetic Field Strength or Intensity. When a unit pole is acted upon with a force of one dyne, the field surrounding

it has an intensity of unity in the C. G. S. system. The name *gauss* is given to this unit.

With intensity of field defined, all other definitions follow naturally and logically in the C. G. S. system and in the following order.

C. G. S. Unit of Electromotive Force. *Experimental Facts.* When a conductor is moved across a magnetic field there is produced in it a tendency to set up an electric current. This tendency is proportional to the intensity of the field and to the velocity of cutting.

Definition of Unit. The C. G. S. unit of electromotive force is that produced by the cutting of a field of one gauss intensity at a velocity of one centimeter per second (in a direction normal to the field and to the conductor) by one centimeter of conductor.

One hundred million times this is the *volt*.

C. G. S. Unit of Current. *Experimental Facts.* Under certain conditions the conductor is urged across the magnetic field. The force is proportional to the length of the conductor and to the strength of the field. The force indicates the presence of an electric current in the conductor.

Definition of Unit. The C. G. S. unit of current exists in a conductor (located in a plane normal to the field) when each centimeter is urged across a magnetic field of one gauss intensity with a force of one dyne.

One-tenth of this unit is the *ampere*.

C. G. S. Unit of Quantity of Electricity. *Experimental Facts.* When a current flows for a length of time a definite amount of effect is produced. This is proportional to the current and the time, and the product is known as the *quantity of electricity*.

Definition of Unit. The unit of quantity is that repre-

sented by the flow of one C. G. S. unit of current for one second.

One tenth of this is the *coulomb*.

C. G. S. Unit of Electric Power. *Experimental Facts.* When current and electromotive force are present in a circuit a transformation of energy takes place. The rate of this is proportional to the product of current and electromotive force. In fact, since (in a magnetic field) electromotive force is proportional to the velocity, and current to force, this is evident from the definitions of these quantities.

Definition of Unit. The unit of electric power is that represented by the flow of one C. G. S. unit of current under a pressure of one C. G. S. unit of electromotive force.

Ten million times this is the *watt*.

C. G. S. Unit of Electrical Energy. *Experimental Facts.* The duration of electrical power represents a transfer of energy, the quantity of which is equal to the product of power and time.

Definition of Unit. The C. G. S. unit of electrical energy is that represented by the flow of one C. G. S. unit of electric power for one second.

Ten million times this is the *joule*.

C. G. S. Unit of Resistance. *Experimental Facts.* By Ohm's Law the resistance in a circuit is the ratio of the electromotive force to the current.

Definition of Unit. The C. G. S. unit of resistance is that in which one C. G. S. unit of current is maintained by one C. G. S. unit of electromotive force.

One billion times this is the *ohm*.

C. G. S. Unit of Inductance. *Experimental Facts.* A changing current in a circuit produces an electromotive force which is proportional to its rate of change.

Definition of Unit. The C. G. S. unit of inductance is that in which the rate of change of one C. G. S. unit of current per second produces one C. G. S. unit of electromotive force.

One billion times this is the *henry*.

C. G. S. Unit of Capacity. *Experimental Facts.* A quantity of electricity is stored in the dielectric separating the conductors of a circuit proportional to the applied electromotive force. The rate of change of this quantity, or the current, is proportional to the rate of change of the electromotive force.

Definition of Unit. The C. G. S. unit of capacity exists in a circuit when a C. G. S. unit of quantity per C. G. S. unit of applied pressure is absorbed in the dielectric separating the conductors, or when a C. G. S. unit of current flows into the dielectric per C. G. S. unit rate of change of the electromotive force.

One billion times this is the *farad*.

Summary of Definition of Units.

In viewing the definitions as a whole, it will be noted that these group themselves into two general classes.

1. Definitions of properties of electric circuits.
2. Definitions of conditions of electric circuits.

There are but three properties of an electric circuit: resistance, inductance, and capacity. These depend upon the material and dimensions of the conductors and upon their relation to each other.

All of the other quantities defined represent conditions of the circuit when transmitting electric current or power, or when having a tendency to produce a current. It will be noted that properties have been in general defined in terms of conditions. It is only when the circuit is subjected to

certain conditions that the properties become manifest. For example, electrical resistance is evident only when current is flowing; inductance, when current is changing; and capacity, when electromotive force is changing. Taking the corresponding mechanical analogies, mechanical resistance requires motion to bring it into action, inertia requires change of velocity, and elasticity requires displacement.

CHAPTER III.

MATERIALS OF ELECTRICAL ENGINEERING.

OUTLINE.

Conducting Materials: Copper — aluminum — iron and steel — alloys (german silver, manganin, fusible alloys) — carbon — liquids.

Properties of Conducting Materials: Specific resistance — temperature coefficient — summary.

Wire gauges.

Magnetic Materials: Induction and Magnetomotive Force.

Ewing's Theory: Magnetic flux and flux density.

Properties of Magnetic Materials: Permeability — hysteresis coefficient — retentiveness.

Characteristics of Various Materials: Cast iron — cast steel — electrical steel — wrought iron — alloys.

Insulating Materials: Electrical properties of dielectrics.

Rupturing Gradient: Specific inductive capacity — specific resistance.

Dielectric Materials: Air — glass — porcelain — mica — rubber — paper — fiber — cloth — yarn — waxes — varnishes — oils.

THE historical survey of electrical devices which has been made in Chapter I has indicated that in a motor, generator, or other electrical apparatus, there are magnetic materials in which the magnetic field may be produced; conducting materials for carrying the current; and insulation for electrically separating the conductors from surrounding material. These different materials must possess mechanical strength so that they may keep their proper form, and in many cases additional mechanical support must be provided for the electric and magnetic circuits. The general principles of mechanics

and machine design apply to the support of electric conductors whether these form parts of electric machines or of transmission circuits.

For convenience all of these materials may be classified as follows:

(1) Materials used for the mechanical support of electric and magnetic circuits.

(2) Conducting materials of electric circuits.

(a) Materials used for conducting current economically; copper, aluminum, iron and steel.

(b) Materials used for controlling the flow of current (resistance materials); iron, steel, german silver, manganin and other alloys.

(3) Magnetic materials.

Iron and steel are the only materials suitable for the construction of magnetic circuits.

(4) Dielectric or insulating materials.

For the mechanical support of conductors and magnetic circuits the general principles of machine design apply. As this subject is beyond the scope of the present purpose, materials used for this purpose will not be discussed.

Conducting Materials.

By the term "conducting materials" is meant those in which the resistance is small compared with others. Materials were separated by Du Fay into conductors and non-conductors as a result of his experiments, which showed that those materials which electrify most readily by rubbing conduct a charge with the greatest difficulty. On the other hand, those which conduct readily do not receive any considerable charge by rubbing. While it is true that all materials conduct electricity to a certain extent, the difference between the resist-

ance of conductors and non-conductors is so great that there is no difficulty in distinguishing between them. For example, the relative conductivity of a good conductor may be as high as ten raised to the 20th power to one. The best conductors are pure metals, and metals are the only conductors now used for transmitting power economically. Steel, while not a pure metal, is necessarily used for the return circuits of electric railways. Alloys are used for resistance materials, that is, those the purpose of which is to control the flow of a current or to transform electrical energy into heat. As an example of the latter use of conductors may be cited the employment of current in coils of wire to produce heat in street cars. In addition to alloys, liquids and carbon are also used as resistance materials.

Various Materials.

Copper. Copper is the most important conducting material for all kinds of service. It is the best all around conductor because with a given cross-sectional area it has the greatest conductivity. It is used for the distributing systems of railways and lighting and power installations. Where mechanical strength is not of great importance the copper is "soft drawn," while for trolley wires and transmission lines in which hardness and tensile strength are important it is "hard drawn." Copper occurs in nature in two forms,—the sulphide ores and the conglomerate or native copper. In the latter form the copper is in a metallic state, and in masses varying from a few grams to many tons weight. In preparing the sulphide ore for use in electrical conductors it is first "roasted" to remove the sulphur, then melted and run into rough ingots. The conglomerate requires no roasting. The metal is separated from the binding material by stamping, which pulverizes the material in which the copper masses are held. The lighter

substances are washed out, and the copper is cast into slabs for refining.

For electrical purposes the best copper is that which is electrolytically refined. There are numerous impurities which cannot be removed by the roasting and smelting processes. Electrolysis offers an easy means for separating the copper, silver, and impurities from each other. In refining, the ingots are surrounded with heavy bagging and suspended in a nearly saturated solution of copper sulphate. Current is sent through the liquid from the ingots to plates of pure copper forming the negative terminals of the bath. The copper is thus dissolved from the impure ingots and is deposited upon the negative plates in a practically pure state. As only copper is dissolved from the ingot any rare metals present will be left behind in the bagging and may be dissolved and deposited. After the pure copper has been deposited in this manner it is remelted and cast into ingots of the proper size for rolling. In the rolling mill the ingot is reduced to a rod somewhat larger than the wire which is to be made from it. It is maintained at a red heat during this process. Wire is made from the rods by drawing through dies of diminishing size until the desired diameter is reached. During the process of drawing the metal has a tendency to harden, and it must, therefore, be annealed from time to time. The difference between hard and soft drawn wire is made entirely by the number of times which it is annealed during the drawing.

Aluminum. Aluminum is one of the most plentiful metals in nature, but it has been until recently very expensive to recover. All forms of clay contain it, but even with modern processes it is not practicable to reduce the metal from any but the purest oxides. The metal cannot be directly smelted from its ores on account of their highly refractory nature. The

direct source of the metal is the oxide known as alumina (Al_2O_3). This alumina is produced from the mineral bauxite which occurs in some of the southern states and in Europe. The process of producing alumina from bauxite is roughly as follows: It is first roasted to drive off organic matter and to oxidize the iron present. It is then crushed in a stamping machine and the aluminum dissolved out with sodium hydroxide. The insoluble residue is discarded, and carbon dioxide is forced through the sodium aluminate, forming sodium carbonate and precipitating aluminum oxide. The precipitated alumina, after washing and drying, is shipped to the smelting works in the form of a white powder. In order to subject the alumina to the action of electrolysis it is necessary to dissolve it in fused cryolite, the double fluoride of aluminum and sodium. The cryolite is contained in a carbon-lined iron box and is kept liquid by the heat due to the flow of the current through the resistance. The current passes from large carbon rods in the center to the carbon lining. As alumina is dissolved in the bath the metal is reduced at the negative terminal or lining, and the high temperature of the bath keeps it molten. As it is heavier than the cryolite it remains on the bottom of the furnace, from which it is removed in practically pure state.

The production of wire from aluminum does not differ materially from the process already described for copper. The wire, however, is always made stranded; that is, each wire is made up of numerous smaller ones spirally wrapped together. This is essential, as it is impossible to keep occasional impurities out of the wire. Such impurities are a serious cause of breakage.

Pure aluminum has about one-third the specific gravity of copper and a much lower conductivity. An aluminum wire of the same conductivity as a copper wire will have an area at least 60 per cent greater if pure, and up to 70 per cent

greater if alloyed with other metal to increase tensile strength. Its weight will be slightly over one-half that of the copper, so that the two metals may be sold in competition, on the basis of conductivity, when aluminum costs nearly twice as much as copper. The tensile strength of aluminum is much less than that of copper, even on the basis of equal conductivity. Perrine gives a value of about 33,000 pounds per square inch for hard drawn aluminum, and nearly twice that value (about 60,000 pounds per square inch) for hard drawn copper.

*Problem Illustrating the Comparative Qualities of
Aluminum and Copper.*

In a transmission line three hard drawn copper wires, with a conductivity 97 per cent as great as pure copper, are employed. The wire is 0.182 inch in diameter, and there are 9.98 feet of it in a pound. Determine the following item: *a*, tensile strength of copper line; *b*, tensile strength of an aluminum line of same conductivity; *c*, feet per pound of this aluminum wire; *d*, diameter of the aluminum wire; *e*, price per pound of aluminum equivalent in conductivity to copper, when the latter is 16 cents per pound.

*Ans. a. 1561 pounds; b. 1332 pounds; c. 19.3 feet;
d. 0.227 inch; e. 31 cents.*

Iron and Steel. The conductivity of iron and steel is small compared with that of copper and aluminum. Pure iron has nearly six and hard steel about twelve times the resistance of copper. They have, however, high tensile strength, and where this rather than conductivity is the important consideration they are less expensive than copper. They are used largely in telegraph and telephone service, but copper is gradually displacing them. In very long spans in high tension transmission lines steel is occasionally used

on account of its strength and in spite of its low conductivity. As the service rails of electric railways are usually used as the return circuit, the conducting properties of steel are of practical importance in that class of service.

Pure iron is very difficult to obtain, and it is expensive, so that steel is used in its place wherever possible. Both iron and steel must be galvanized to protect them from oxidation.

*Problem to Illustrate Relative Conductivity of
Steel and Copper.*

A track is built of 66-pound rails (66 pounds per yard). The rails are 30 feet long, and the lengths are "bonded" together with 30-inch round copper bonds. Assuming a conductivity of one-twelfth that of copper for the steel, what should be the cross-section of the bonds to give a bond resistance equal to one-fifth that of the rails? (Steel rails weigh 0.280 pound per cubic inch.)

Ans. 0.227 square inch.

Alloys. The union of two or more metals differs materially in its properties from the constituent metals. This alloy may have one or more of the following characteristics:

- (a) Increased tensile strength.
- (b) Increased resistance.
- (c) Decreased melting temperature.
- (d) Decreased change of resistance with temperature.

As increased tensile strength is usually secured at a sacrifice of conductivity, alloys are employed for this purpose only when hard drawing will not produce the desired result. The high resistance of alloys renders them desirable for use as resistance materials, especially as this high resistance is reasonably constant with varying temperature. In some cases the low melting temperature secured by alloying is a desirable

feature. This is the case in fuses which are intended to melt and open a circuit when the current exceeds a certain value.

German Silver. German silver is an alloy of copper, nickel, and zinc of varying proportions. Average values of the compounds may be taken as 56 per cent copper, 20 per cent nickel, and 24 per cent zinc. The resistance of this alloy is nearly fifteen times that of copper. It is, therefore, convenient for use in resistance coils used for controlling the flow of current or for producing heat from an electric current.

Manganin. In connection with electrical instruments a resistance metal is necessary which shall have a constant resistance regardless of the temperature. Large currents are usually measured by sending them through "shunts" across the terminals of which are connected delicate voltmeters. In the construction of these shunts an alloy of copper, ferromanganese, and nickel is used. It is remarkable for its high resistance, nearly thirty times that of copper. More important still, this resistance is practically constant for all ranges of temperature.

Fusible Alloys. By the combination of tin, bismuth, and lead, it is possible to make alloys which will melt at very low temperatures. For example, a combination of one part of tin, two of bismuth, and one of lead, will melt at less than 100 degrees Centigrade. These alloys are formed into wires or strips and soldered between copper terminals. When connected in electric circuits they act as safety fuses, melting when the current produces an excessive temperature.

Carbon. While not as good a conductor as the metals, carbon is an important conducting material. The "brushes" through which current is conducted to and from direct current motors and generators are made of carbon, as are also the

filaments of most incandescent lamps. The "carbons" of arc lamps are obviously of this material. Carbon has a high resistance compared with that of copper, and this resistance may be made greater or less by different processes of manufacture. By suitable combinations of the graphitic and amorphous forms it may be adapted to various uses in electrical work, such as those specified.

Liquids. For the control of current it is often convenient to use a liquid resistance. Pure water is a non-conductor, but if small quantities of salt, sulphuric acid or other substance be dissolved in it, any desired degree of conductivity may be secured. Liquid resistances are particularly convenient for absorbing power in electrical testing, and they are sometimes used for more permanent work. The liquid is usually carried in a wooden box, known as a "water box." Metal terminals are immersed in the water, and the resistance is adjusted by varying the area of immersion of the terminals or by altering the distance between them. The resistance is further affected by the amount of foreign material in the water.

Properties of Conducting Materials.

Specific Resistance. As a basis of comparison the resistance of a sample of given dimensions is most convenient. The resistance between two opposite faces of a centimeter cube of a material is called its specific resistance. For practical purposes materials are usually compared by reference to wires one foot long, one-thousandth of an inch in diameter, and of circular cross-section. The area of a wire one-thousandth of an inch or one mil in diameter is called a *circular mil*, and the dimensions of the wire are covered by the term *circular mil-foot* or simply *mil-foot*. The resistance of any wire may be

calculated if the dimensions and the specific resistance or the resistance of a mil-foot are known. The resistance is:

$$R = \frac{l \times R_{sp}}{A}$$

Where l is length, R_{sp} is the specific resistance, or the resistance of a mil-foot, and A is the area.

Illustrative Problems.

If the resistance of a mil-foot of copper is 10 ohms, what will be that of a wire 10 miles long and 0.25 inch diameter?

Ans. 8.45 ohms.

A sample of aluminum wire one-half inch in diameter under test shows a pressure drop of 0.0192 volt in a length of three feet with a current of 100 amperes. What is its specific resistance in C. G. S. units, and what the resistance of a mil-foot in ohms?

Ans. 2660 C. G. S. units; 16 ohms.

Temperature Coefficient. The resistance of all metals varies with temperature, the variation of pure metals being a rise of about four-tenths per cent per degree C. *The temperature coefficient is the proportional (not per cent) change in resistance per degree C. from 0 degrees.* This may be reduced by combining different metals. These facts are summarized in the following table:

TABLE OF SPECIFIC RESISTANCES AND TEMPERATURE COEFFICIENTS
FROM 0 DEGREES.

Material.	Resistance of round wire 1 ft. long, .001 in. diameter at 0° C.	Temperature Coefficients.
Copper (soft, pure)	9.612	.004284
Aluminum (soft, pure)	16.02	.0039
Iron (soft, pure)	60.00	.00453
German Silver, average	127.00	.00044
Manganin, average	291.00	± .00001

Illustrative Problems.

The field coils of a street railway motor have a resistance of 0.25 ohm at a temperature of 70° Fahr. After operating for some time the resistance is again measured and is found to be 0.31 ohm. What has been the average rise of temperature of the coils? *Ans.* 109.6° Fahr.

The resistance of the filament of an incandescent lamp at a temperature of 20° C. is 50.1 ohms. When operating under normal conditions at a temperature of 2000° a pressure of 110 volts sends a current of 0.37 ampere through the filament. What is the average temperature coefficient of the filament? (This is a tantalum lamp.) *Ans.* 0.00262.

Summary of Properties of Conducting Materials. The following synopsis shows in brief the principal engineering features of the various conducting materials and a few of their applications.

Copper. Best conductivity, smallest surface; can be hard drawn without great loss of conductivity. Used for indoor and outdoor work where insulation is needed and where space must be economized, and for conductors in electrical machinery.

Aluminum. Light weight; used for transmission lines which are not insulated, its large surface making insulation too expensive.

Iron and Steel. Used sometimes as feeders and contact rails on account of durability and large surface exposed, and practically always as street railway return circuits. As street railways must have the rails, these are used for return as a matter of course. As a resistance material, iron is very satisfactory, as it exposes a considerable surface for radiation and is cheap.

German Silver. High specific resistance. Fairly low temperature coefficient. Used in resistance boxes to some extent.

Manganin. High specific resistance, low temperature coefficient. Used for resistance and for shunts for measuring instruments.

Carbon. High resistance. Used for resistances, and for brushes for electrical machines. Also in arc and incandescent lamps.

Wire Gages. Conductors for electric circuits are made of round or rectangular wire, the former being used for all kinds of transmission circuits, the latter for certain parts of electrical machines. Round wire is manufactured in certain definite sizes in accordance with the American or Brown and Sharp (B. & S.) gage. This gage covers sizes from No. 0000 to No. 40, the former being 0.46 inch and the latter 0.00314 inch in diameter. In this gage the area practically doubles every three sizes, beginning with No. 40, so that No. 37 is twice as large as No. 40, No. 7 twice as large as No. 10, etc. The data for the wires of the American gage are given in tabular form in the appendix. Conductors larger than No. 0000 are known by their areas in circular mils, while the sizes of these smaller than No. 40 are given by area or diameter. Very large conductors are often stranded, and are rated by the net area of copper in circular mils.

Magnetic Materials.

The fundamental facts regarding magnetism, known long before the time of Gilbert, were:

- (a) that only iron is attracted to lodestone,
- (b) that the attractive property may be transmitted from the lodestone to the iron, so that the latter in turn will attract other iron. Evidently iron possesses some quality not inherent

in other metals, and iron and some of its derivatives are called *Magnetic Materials* to distinguish them from others in this particular.

Induction and Magnetomotive Force.

When a piece of iron is placed in a magnetic field it becomes a magnet. This operation of making a magnet of the iron is called *induction*, the magnetic field *inducing* the attractive quality in it. The ability of the field to induce the attractive quality is called *magnetomotive force*. The magnetomotive force may be produced either by a previously magnetized piece of magnetic material or by a coil of wire carrying a current. The material in which a given strength of field produces the greatest effect is the best magnetic material.

Ewing's Theory. The commonly accepted explanation of magnetic induction of iron is that proposed by Professor

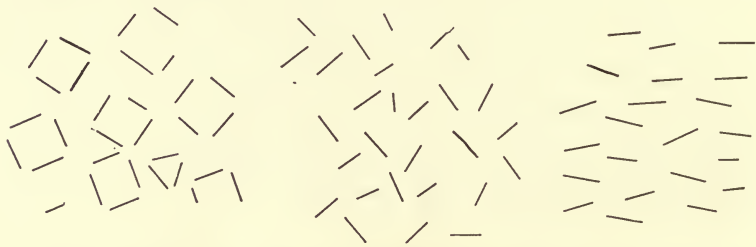

FIG. 27. Diagrams representing molecular magnets arranged in accordance with Ewing's theory of magnetism.

J. A. Ewing. If each molecule of a magnetic material is a natural permanent magnet with north and south poles, the various magnetic phenomena may be explained. Such magnets when placed in a magnetic field will tend to place themselves in line with that field. Before a piece of iron is magnetized the attractions of the molecular magnets for each

other prevent the production of any external attraction. If, however, the molecules are subjected to an externally applied directing force such as that produced by a magnet or a coil of wire carrying a current, they will tend to take the direction of the force. The molecules which were previously arranged in stable groups within the iron now tend to assist the directing force by their attractions for each other. The external effect then becomes the sum of the applied magnetomotive force and that produced by the molecular magnets. So great is this ability of the molecular magnets to increase the magnetomotive force that the combined effect may be several thousand times that of the field alone. This property is given the name *magnetic permeability*.

Ewing's theory affords a satisfactory explanation of magnetic induction. It is seen that this well-known property of the magnetic field is due to its ability to bring out the latent magnetic property of the iron.

Magnetic Flux and Flux Density. The "attractive property" of a magnetic field was used in Chapter II to define its strength or intensity. It is very convenient for practical purposes to consider the field as filled with a certain *flux* just as a conductor is said to carry a *current*, although of the nature of flux or current very little is known. A field of unit intensity is said to have a unit of flux in each square centimeter of cross-sectional area. In other words, *in non-magnetic materials, a unit of intensity of flux is the same as unit intensity of field*. The name *maxwell* is given to a unit quantity of flux, and *one maxwell per square centimeter in non-magnetic materials is the same as the gauss*. (In magnetic materials the flux produced by the molecular magnets is added to that of the field.) The unit of magnetomotive force is given the name *gilbert*. An ampere of current flowing through one turn of wire produces 1.257 gilberts of magnetomotive force.

In a magnetic material a gilbert of applied magnetomotive force will produce much more flux than it would in a non-magnetic material due to its permeability. The permeability, which can only be determined experimentally, is numerically equal to the ratio between the flux per square centimeter produced by a gilbert per centimeter in a magnetic material and in non-magnetic material. The latter is said to have a permeability of unity, a gilbert per centimeter producing unit density of flux.

Problems Illustrating Magnetic Units.

Express a field intensity of 10,000 gaussses in maxwells per square inch. *Ans.* 64,500.

The e. m. f. generated in a conductor is proportional to the product of flux density, length of conductor and velocity. In the C. G. S. system it is equal to this product. The average e. m. f. (in the C. G. S. system) is equal to the total flux divided by the time in which it is cut.

Let B = flux density in maxwells per square centimeter.

ϕ = total flux in maxwells.

l = length of conductor in centimeters.

v = velocity of conductor in cms. per second.

t = time of cutting the field in seconds.

Then

$$e. m. f. = Blv.$$

$$B = \frac{\phi}{vlt}.$$

By substitution

$$e. m. f. = \frac{\phi}{t}$$

In the air gap of the generator shown in Fig. 28 a flux of 2,000,000 maxwells exists under each pole. At a speed of 1200 r. p. m. what e. m. f. is generated in each conductor on the armature? *Ans.* 0.8 volt.

If the poles cover 70 per cent of the armature surface of the above generator, and the armature is one foot long, one foot in diameter, and the field strength is 5000 gaussses (flux

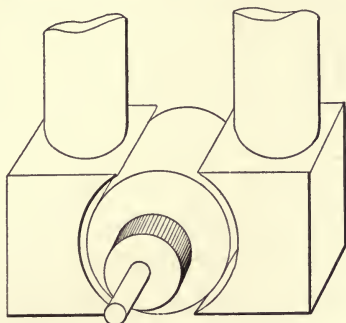

FIG. 28. Diagrammatic representation of electric generator illustrating problem.

density 5000 maxwells per sq. cm.) at the armature surface, what average e. m. f. is generated in each conductor?

Ans. 2.034 volts.

The mechanical force is proportional to the product of flux density, length of conductor and current. In the C. G. S. system it is equal to this product.

Let f = mechanical force in dynes acting upon the conductor.

l = length of the conductor in centimeters.

B = flux density in maxwells per square centimeter.

I = current in conductor in C. G. S. units.

Then $f = BIl$.

In pounds the force will be approximately f divided by 445,000.

In the two preceding problems calculate the force in pounds upon each conductor tending to resist the motion of the armature when the current in each conductor is 25 amperes.

Ans. 0.336 lb. maximum force. 0.857 pound.

Properties of Magnetic Materials.

The magnetic properties of iron and steel are, according to Ewing's theory, due to inherent molecular magnetism giving rise to *permeability*. The process of magnetizing iron consists in displacing the molecular magnets, and this involves a loss of energy which reappears as heat. The cause of the loss is given the name *hysteresis*. The amount of energy lost in magnetizing and demagnetizing a unit volume of material is the *hysteresis coefficient* of the material. As this is most important in alternating current work, the coefficient is given for a complete cycle of magnetization, comprising a magnetization in one direction, then in the opposite direction and back to the original condition. Steel which is to be used for permanent magnets must have the ability to retain its magnetism after the applied magnetomotive force is removed. Even the softest iron will produce some external flux after having been subjected to a magnetizing force, but this is easily removed by mechanical vibration or by the application of a small *demagnetizing* or *coercive magnetomotive force*. In hard steel the magnetism is more permanent, and the ability to retain the attractive property is called *retentiveness*.

Permeability (Symbol μ). Permeability is somewhat analogous to specific conductivity in conducting materials, but is much less constant. It varies with the following quantities:

- (a) Flux density.
- (b) Chemical composition.
- (c) Physical treatment.

Effect of Flux Density upon μ . In any given sample of iron the magnetic flux density will increase with magnetomotive force as shown in Figs. 29, 30, 31, and 32. A unit increase of the latter at first produces very slight change in flux density

but this increases to a certain point and then decreases. As the permeability is the ratio of the flux density to the magnetomotive force per unit length, it may be calculated from the $B-H$ curve. Its values are plotted against flux density in the same figures. The variation in permeability is so great that it is necessary to use an experimentally determined curve for each material in all problems involving the use of iron or steel.

Effect of Physical Treatment upon μ . In general any treatment which restricts the freedom of motion of the molecules decreases permeability. Hardening does this, while annealing has the opposite effect. Similarly heat increases permeability up to a very high temperature, while chilling produces the same effect as hardening.

Effect of Chemical Composition upon μ . Pure iron is the best magnetic material, but it is difficult to obtain. Commercial iron contains a number of impurities, the most important being combined carbon. This is, in many cases, a necessary constituent, added to improve mechanical qualities or to permit casting. The effect is always to lower the permeability. The extreme case is cast iron with from 0.2 to 0.8 per cent of combined carbon and from 3.0 to 4.5 per cent total carbon which reduce μ to about one-half the values of pure iron. On the other hand, cast steel with about 0.25 per cent combined and no graphitic carbon has a high permeability. It is possible to improve the mechanical properties of iron by the addition of other metals, such as nickel, manganese and aluminum. These metals do not seriously lower the permeability, while the tensile strength is considerably increased.

Hysteresis Coefficient (Symbol η). High permeability is accompanied by small hysteresis loss, as the molecules will absorb the least energy when most mobile.

The hysteresis loss varies with the flux density in accordance with a law experimentally determined by Dr. Steinmetz. Steinmetz's law states that *the loss by hysteresis is proportional to the one and six-tenths power of the flux density*. The coefficient, however, is constant for any sample of iron if its physical condition is not altered. The values of η are given as the ergs per unit of volume, per cycle of magnetization and per unit of flux density. The numerical values will depend upon the units employed.

The hysteresis loss in watts is,

$$P_h = \frac{\eta \times B^{1.6} \times V \times f}{10^7}$$

where η is the hysteresis coefficient;

B is the maximum value of flux density;

V is the volume;

f is the number of cycles of magnetization per unit of time.

Iron for use with alternating flux should have a coefficient not over 0.001, with B in maxwells per square inch, V in cubic inches and f in cycles per second.

The coefficient is increased by the presence of impurities to such an extent that it is necessary to employ practically pure iron for use with alternating flux. At present the improvements in the quality of iron for generator and motor armatures and transformer cores are largely through better physical treatment, particularly in annealing. Iron annealed for minimum hysteresis coefficient is sensitive to overheating in service. If overheated (e.g., above 90° C.) the coefficient increases after a time, producing the phenomenon called *ageing*.

Problem Illustrating the Use of the Hysteresis Coefficient.

A generator has four poles, and its armature makes 800 revolutions per minute. The maximum flux density in the core is 80,000 maxwells per square inch, and the volume of the core carrying flux is one cubic foot. What is the hysteresis loss? (Assume η at 0.0010 in inch system, with frequency in cycles per second.)

Ans. Approximately 0.3225 K.W.

Retentiveness. Steel for use in permanent magnets must retain its magnetism against the action of vibration and other

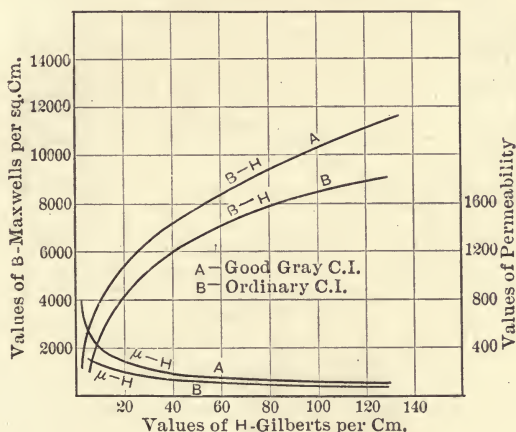

FIG. 29. Curves showing magnetic qualities of good and ordinary cast iron. (This and Figs. 30, 31 and 32 are from the Transactions of the Am. Soc. for Testing Materials.)

demagnetizing agencies. Any treatment which tends to restrict the motion of the molecules increases retentiveness. High carbon steel, hardened to a maximum degree, makes, therefore, the best permanent magnets. Such steel when once highly magnetized will retain its properties for an indefinite time. The strongest magnet can be produced by subjecting



the steel to a magnetizing force when hot, and chilling it without removing the magnetizing force.

Characteristics of Various Magnetic Materials. The important materials are cast iron, cast steel, electrical steel (in sheets), wrought iron, iron alloys.

Cast Iron. Cast iron is a very useful material on account of its cheapness and the ease with which it can be molded. It can be used only with steady flux, as the energy losses with

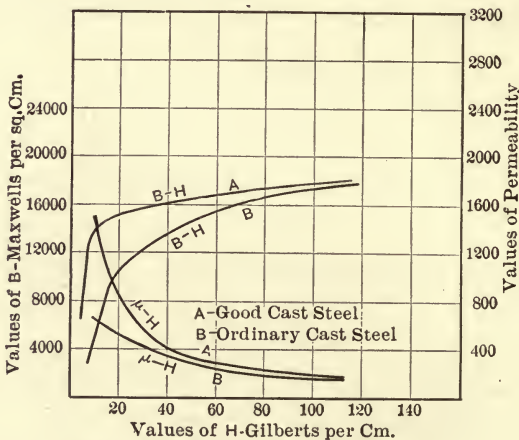

FIG. 30. Curves showing magnetic qualities of good and ordinary cast steel.

even slightly variable flux are excessive. When generator and motor parts for carrying magnetic flux are made of cast iron they are twice as heavy as when made of steel, as the permeability of the latter is twice as great as that of the former. The gray cast iron used for magnetic purposes has an average chemical composition as follows: carbon (comb.), 0.5 per cent; graphite, 3.0 per cent; phosphorus, 0.8 per cent; silicon, 2.0 per cent; manganese, 0.5 per cent; sulphur, 0.06 per cent. The castings should be as soft as possible. Cast iron is not mechan-

ically strong, its average tensile strength being 16,000 pounds per square inch, and its compressive strength 90,000 pounds per square inch.

Cast Steel. Cast steel has all of the merits of cast iron except that of cheapness. As its permeability is high it makes lighter magnet cores than cast iron, and it is therefore used wherever lightness or small volume is an important consideration. Examples of such cases are found in railway motor frames,

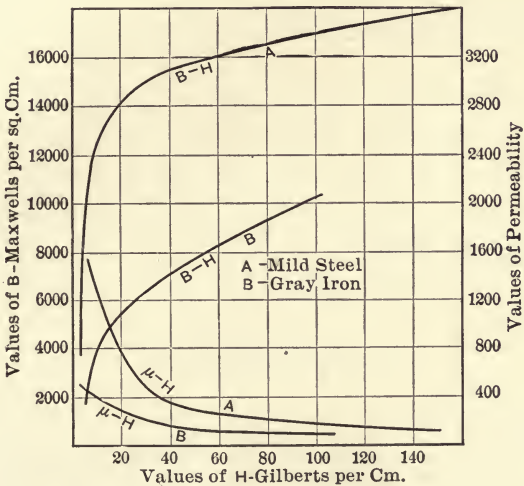

FIG. 31. Curves showing magnetic qualities of mild steel and gray iron.

and in pole cores of motors and generators. Railway motors must be compact to permit them to be placed in restricted space, and light to minimize "dead weight" carried by the car. Pole cores must be small to save copper in the coils placed upon them, the weight of copper being proportional to the periphery of the core. Average steel for castings has a chemical composition of carbon (comb.), 0.25 per cent; phosphorus, 0.08 per cent; silicon, 0.20 per cent; manganese, 0.50

per cent; sulphur, 0.05 per cent. The best results are secured when the castings are soft. Cast steel is only used with steady flux. Cast steel is mechanically stronger than cast iron, an average tensile strength being 60,000 pounds per square inch, and compressive strength 200,000 pounds per square inch. These figures are merely suggestive, as the strength of irons and steels varies greatly with hardness as well as with chemical composition.

Electrical Steel. Parts of electrical machines which carry alternating flux must be made of practically pure iron. Such

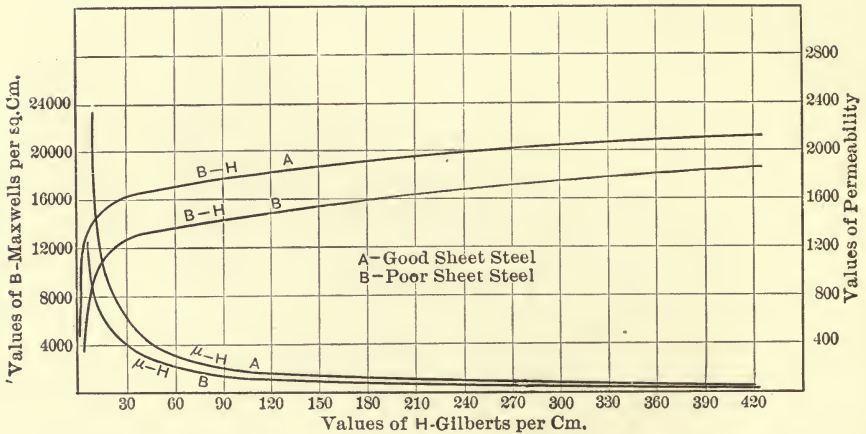

FIG. 32. Curves showing magnetic qualities of good and poor sheet steel.

parts are always built up of sheets to minimize the circulation of eddy currents due to the cutting of the iron by the flux. To permit rolling into sheets a very ductile material must be used, and this quality is fortunately combined with good magnetic qualities. These steel sheets have the highest permeability and lowest hysteresis coefficient, and the quality is being constantly improved. The annealing of the sheets is a most important matter. Manufacturers of electrical machinery do

their own annealing to insure the best results. Good steel sheets contain approximately: carbon, 0.05 per cent; silicon, trace; manganese, 0.3 per cent; sulphur, 0.03 per cent; phosphorus, 0.10 per cent. While mechanically weak in itself, sheet steel may be so supported by iron or steel castings or forgings as to permit the laminated structure to withstand the great strains brought upon it.

Wrought Iron. Iron forgings are seldom used in electrical machines at the present time, because steel castings are cheaper and just as effective. At one time forgings were frequently employed for magnetic circuits.

Steel Alloys. Occasionally a case arises in which great mechanical strength and reliability combined with excellent magnetic qualities are requisites. An alloy of steel and nickel or some other metal may possess the desired characteristics. As such forgings are very expensive they are employed only when absolutely necessary.

Insulating Materials.

In order to prevent leakage of current between conductors in an electrical machine or transmission line, it is necessary to insulate them by means of dielectric materials. Wires are covered with insulation of cotton, asbestos or rubber. They are mounted upon glass or porcelain insulators, or if wound upon an armature or field core the coils are surrounded by mica, oiled cloth, or paper or cloth tape in addition to the covering upon the wire. In transformers, in addition to other insulation, the coils are frequently immersed in oil which impregnates and supplements other insulating material. Among the important dielectrics are the following: air, glass, mica, porcelain, rubber, asbestos, paper, cloth, paraffin, wax, shellac, copal, sulphur, various oils and combinations of two or more

of these. Evidently these materials are of different mechanical forms, some being fluid, others solid; some may be worked with tools, others must be molded to form; some have stability, others must be supported. There is, however, a place for every good dielectric material, as the requirements are varied. Each substance must be selected for its particular purpose with the following considerations taken into account:

- (a) Electrical properties.
- (b) Mechanical fitness; strength, fluidity, ease of working, durability, and other items as the circumstances dictate.
- (c) Heat-resisting ability.
- (d) Durability under action of weather and chemicals.

Electrical Properties of Dielectrics. In order to judge the merits of dielectrics as such, a knowledge of certain distinctive properties is necessary. The most important is the amount of electric pressure which a given thickness of the material will withstand without puncturing. This may be termed the *dielectric strength* of the material.

Electric Pressure Rupturing Gradient. Dr. Steinmetz has given this name to the number of volts per inch of thickness necessary to rupture the material. This is the most important property of dielectrics, as their function is primarily to prevent the passage of current between conductors. As a rule the break-down is sudden, the strain being withstood without leakage until the break-down value has been reached. The gradient varies between one million and ten thousand volts per inch, one of the best materials being linseed oil paper, and one of the poorest, air at ordinary pressure.

Specific Inductive Capacity. This is the ratio of the quantity of electricity taken up by a given volume of a dielectric to that taken up by the air at the same pressure. If an e. m. f. is

maintained between two conducting plates separated by air or other dielectric, there will be a certain quantity of electricity absorbed in each dielectric per unit of applied pressure. If the quantity absorbed by a volume of air of given dimensions be known then the corresponding quantity for another material will be the product of this by the specific inductive capacity of the other dielectric. While this property has no direct influence upon the dielectric strength it may be of importance if the quantity of electricity absorbed is very great and especially if the applied pressure is alternating.

Specific Resistance. While of the greatest importance in conductors, resistance is of little importance in insulating materials compared with dielectric strength. Any material which is satisfactory in other ways will be entirely so in this feature. The resistance of the poorest dielectric is very much greater than that of the poorest conductor.

Dielectric Materials.

For convenience the dielectric materials may be divided into gases, liquids and solids.

Air and other Gases. The insulating properties of air are of practical importance as the wires of transmission lines are, as a rule, not covered. Even in the case of many covered wires the insulating covering is depended upon only as a precaution, the wires being installed so that the air furnishes the principal insulation. Air as a dielectric, has many peculiarities, the most important being that the rupturing gradient depends upon the length of path between the conductors separated by the air. The gradient may be more than ten times as great for a very short path, e. g., a quarter inch, as for a long path, e. g., forty inches. The gradient also depends upon the air pressure, being much greater for high than for low pressure.

The specific resistance of air is so high that no leakage can ordinarily occur through it. When the pressure approaches the rupturing value, current flows out into the air in the well-known *brush discharge*. When this phenomenon appears the pressure is too high for satisfactory operation as it represents a power loss and it indicates a small factor of safety from rupture.

Glass and Porcelain. Insulators for supporting electric conductors are usually made of glass or porcelain or both. The materials are easily molded to any form and they possess excellent electrical and fair mechanical properties. The rupturing gradient may be a quarter million volts or more per inch which permits insulators to be made as thin as mechanical strength will allow. It is usually the air distance around the insulator rather than that through the glass or porcelain that determines the resistance to rupture. The inductive capacity, while somewhat greater than that of air is not enough to cause appreciable loss of power.

Mica. Mica is an excellent insulator electrically, but its mechanical properties render its application difficult. Its heat resistance renders its use necessary in many cases. The sheets must be assembled in such a way that they are required to take no mechanical strain except pressure. Mica is used entirely for separating the segments in commutators and for insulating the segments from the supporting structure. Cemented into large sheets with shellac or varnish a material known as micanite is produced. This is useful for lining slots in the armatures of generators and motors, for field spools and for other uses where reasonable mechanical strength is necessary.

Rubber. Rubber is an excellent insulator and is used principally for its water proofing qualities. Its principal field of

application is in the insulation of wires. A layer of soft rubber is applied to the tinned surface of the conductors, the tinning being necessary to prevent the action of the sulphur of the rubber upon the copper. The rubber coating is mechanically protected by cotton braids impregnated with mineral wax compound. Rubber will not stand heat so that when used it should not be raised to such temperatures as will soften it. It is also a source of fire risk for it burns freely when ignited. In general its use is discouraged in locations where fire is apt to originate but in damp locations it is preferred. Rubber is vulcanized by the addition of sulphur, a small proportion rendering it elastic and soft as necessary for use upon wire. A large proportion of sulphur produces hard rubber which is to a limited and decreasing extent employed in the manufacture of electrical apparatus.

Paper and Fiber. These are excellent materials for certain cases, especially when moisture can be kept from them. Soft paper is used upon the cable conductors used for telephone work. Here the paper is wound dry and loose upon wires, and moisture is excluded by the use of lead pipe covering. Wrapped lightly in alternate right and left spiral layers upon conductors, and afterward impregnated with mineral wax compounds, it produces a satisfactory and popular material for lead covered power cables.

Fuller-board, a fibrous material much harder than paper is extensively used in insulating the coils of electrical machines. It is flexible, durable and has good electrical properties. Fuller-board absorbs moisture and must therefore be protected from it. Hard fiber is manufactured in sheets of some thickness. It can be worked like wood and can be used in place of wood or hard rubber.

Paper makes an excellent support for varnishes and oil

and is used in connection with the latter for covering coils in motors, generators, and transformers. When boiled linseed oil is dried in paper, forming "empire" paper, it has as great dielectric strength as any insulating material.

Waxes and Varnishes. Various mineral waxes and vegetable gums are employed in electrical conductors, mainly in connection with fibrous supports. The electrical properties are excellent.

Oils. Oil is increasingly used for supplementing other insulation particularly in transformers. These are usually placed in tanks containing a special grade of oil which possesses fluidity, dielectric strength and low flashing point. High tension switches are immersed in oil as it is possible to break circuits under oil with little arcing. For this purpose a special oil possessing properties somewhat similar to those of transformer oil is required. As already mentioned some oils are dried in fibrous material, but in these cases the effect is produced by the gummy oil residue.

Cloth and Yarn. *Cloth* is mainly used as a support for varnish, oil and wax, and rubber compounds. As in the case of paper it supports dried oil well. It is used in place of paper when greater flexibility is required. In tape, saturated with the materials mentioned above, it can be applied readily and is in universal use.

Yarn, mainly of cotton, is applied either in spiral layers or braided layers to the surface of conductors. Its purpose is mainly to separate these and to act as a support for varnish, wax, etc. If perfectly dry its insulating properties are excellent but in very few cases is it used without some other material.

CHAPTER IV. ELECTRIC CIRCUITS.

OUTLINE.

Construction and Installation of Electric Circuits:

Outdoor Transmission Circuits.

Line Construction — Pole and Tower line — Conduit.

Indoor Circuits: Open wiring — Conduit wiring.

Design and Operation of Electric Circuits:

Varieties of Current — Alternating Quantities in the Steam Engine — Alternating e. m. f. and current — Effective values of Alternating Quantities. — Alternating Current Power. — Phase Displacement of Alternating Quantities — Resistance, Inductance and Capacity in Electric Circuits — Impedance and Reactance.

IN following an electric circuit from the generator to the receiver, several different and distinct sections will be found as follows:

1. The outdoor transmission line.
2. The indoor distributing system.
3. The windings in the electrical machinery connected with the system.

These different sections of the circuit have distinct mechanical and electrical requirements and, hence, must be considered separately. All have features in common and their mechanical features may be best studied in the following order:

- (a) The conducting wires and their insulation.
- (b) The support of the conductors.
- (c) Switching and protective devices.

As electrical machinery windings are the essential parts of such machines they will be studied in connection with the several types of generators, motors and transformers.

Construction and Installation of Electric Circuits.

Circuits are installed for mechanical stability and with precautions against fire risk. All indoors wiring and, to a certain extent, outdoor work as well, is regulated by the rules of the National Board of Fire Underwriters. These rules, known as the "National Electrical Code," are modified annually at the suggestion of the Underwriters' National Electric Association, an advisory body composed of insurance experts and inspectors. The "code" committee of the association confers with engineers and architects and meets annually to revise the rules. These are approved by all national bodies representing engineering and insurance interests.

The National Board maintains in Chicago an information bureau and a laboratory for the testing of all kinds of electrical supplies. It publishes from time to time a list of such devices as are approved and only such "approved" supplies are "passed" by local inspectors. The bureau also collects and distributes information about electrical fires, and in this way emphasizes the importance of a careful following of the rules of the code. The local inspectors are appointed by various associations of insurance companies.

The code rules cover all of the ordinary requirements of lighting and power service, specifying the allowable carrying capacity of wires and the methods to be used in installing them. The dimensions, material, and construction of insulators, switches, fuse cut-outs and circuit breakers are so specified that fire risk may be permanently avoided and these devices are made in a substantial manner to maintain the "risk" a safe one.

Outdoor Transmission Circuit. Outdoor lines are erected primarily for durability and reliability of service. Not only is the continuous working of the plant important, but the danger to life and the disastrous results of crossing with other wires must be considered. The insurance companies are, therefore, justified in imposing restrictions upon methods of

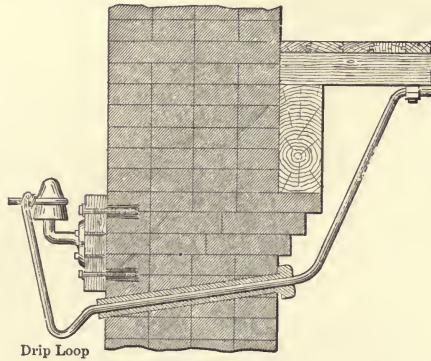

FIG. 33. Method of bringing line wires through wall, showing drip loop. (From hand-book Assoc. Mut. F. Ins. Assn.)

line construction in all cases where the circuits enter or are near an insured building. From the "fire risk" standpoint the following items are considered:

- (a) Insulation of wires and form and material of insulators.
- (b) Location of circuits with respect to other wires and to buildings.
- (c) The use of guard wires or other protecting wires or screens.
- (d) The proper making of joints.
- (e) Grounding of circuits to prevent unsafe rise in pressure in any part.
- (f) The use of section switches to permit cutting out dangerous parts of circuits.

(g) The proper method of entering buildings to insure against the entrance of moisture and to safeguard the structure.

(h) The proper location and installation of transformers and auxiliaries which are likely to become the source of special risk.

Line Construction. Transmission circuits are located either:

- (a) Overhead upon poles or towers, or
- (b) Underground in conduits.

Pole or tower construction is preferred on account of cheapness and ease of inspection and repair. Pole line is used in cross-country stretches and in cities where the pressure used is not excessive and where the size or number of wires is small.

Conduit is used for railway distribution in large cities on account of the great area of the conductors and for telephone work on account of their number. Circuits employing high pressure are also placed under-ground where it is necessary to insure safety to life and property.

Pole and tower line. Poles are cut from oak, cedar, pine, chestnut or other wood, depending upon the locality, the cost of freight, and the degree of durability desired. They range in length from 30 to 60 feet, the long poles being used only where obstructions must be passed over. These poles are set from four to six feet in the ground, and if the ground is soft or if extra durability is desired the butts are surrounded with broken stone or concrete. The poles are spaced from 100 to 200 feet apart. The shorter distance is used for heavy, power conductors, the longer for light telephone wires. The cross-arms which support the insulators are usually of long leaf yellow pine coated with metallic paint and of a length depending upon the number of pins to be carried, i.e., 2-pin, 4-pin, etc. The insulator pins are of iron or wood, locust being considered best for the latter.

The insulators are of glass or porcelain or both, a great variety of forms being used. The general principle in their construction is to obtain a combination of mechanical and dielectric strength. Both glass and porcelain are inherently weak mechanically, so that the main dependence must be placed upon the pin which is iron when much strength is

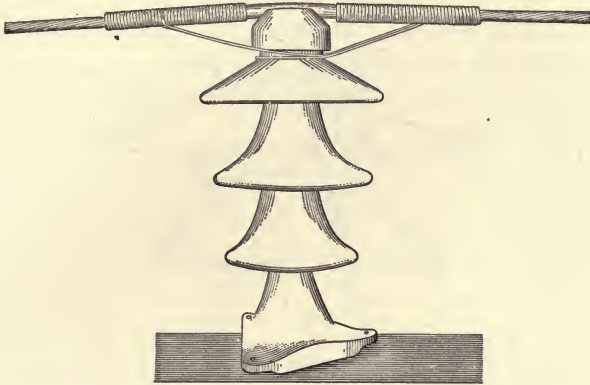

FIG. 34. High tension (60,000 volt) porcelain insulator and iron pin support used on N. Y. State lines of Ontario Power Company.

required. The pin passes through the center of the insulator and frequently it is furnished with a saddle base conforming to the upper side of the cross-arm, with a bolt passing through or a strap passing around the latter. For dielectric strength the insulator is constructed with the necessary distance through the dielectric from conductor to pin. It is further provided with a long surface leakage path from conductor to pin by the use of thin shells or petticoats increasing in diameter from bottom to top. The large top shell to some extent shields the lower ones from rain and thus decreases the likelihood of "flashing over." In general, porcelain is preferred to glass for high pressures on account of its greater uniformity of structure. Brown glaze is employed

to render the insulators less conspicuous as targets. The standard type of insulator has about reached its limit of size and recently a radically different form has been developed. This is the *link* insulator, consisting of a number of disks of porcelain strung together with wire links and hung from the cross-arm.

The conductors are attached to the insulators at the side,

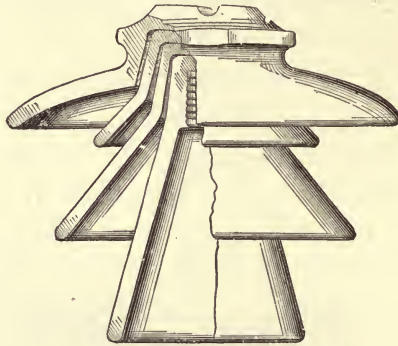

FIG. 35. Insulator for moderate line e. m. f. broken to show section of shells, and method of assembling same.

when not too heavy, or upon the top, as in the case of most power transmission lines. They are bound in position by tie wires and when necessary are reinforced where they pass over the insulators to prevent excessive bending and chafing.

Galvanized steel towers are replacing poles in many cases. Their use permits spans of 500 feet or more and the construction is more sightly and durable. The feet of the towers are attached to concrete foundations. The towers are light for their strength and their breadth of base enables them to resist side and longitudinal strains. They are usually built up of angle iron and angle-iron cross-arms are used with them.

Conductors for power lines are of hard drawn copper or aluminum, with an occasional section of steel where great

tensile strength is required. Some soft drawn copper wire is still used overhead where great strength is not required, e.g., in the feeder circuits of street railway systems. Iron and steel are still used in telephone and telegraph work, but they are being gradually replaced by hard drawn copper. Overhead wires are not insulated except in locations where they are likely to come in contact with other conductors, such, for example, as in the congested overhead space in cities. This insulation is of dubious value and is seldom depended upon for protection. It consists merely of two or three layers

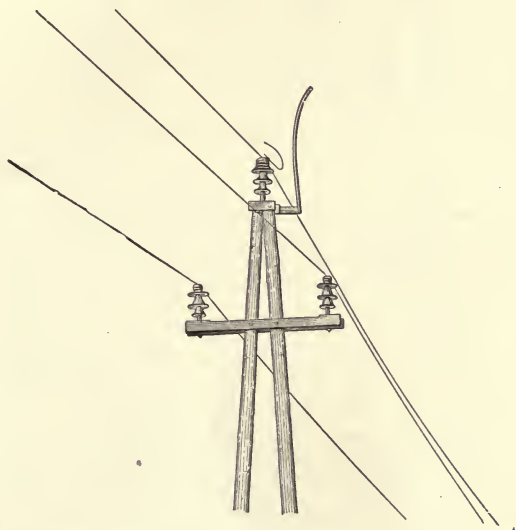

FIG. 36. Horn line arrester used on lines of Ontario Power Company. Bent wire is grounded to carry off line charge.

of cotton braid saturated with a mineral wax compound which is soon removed by the action of the weather.

Protecting Lines from Lightning. The most difficult and unsatisfactory feature of power transmission circuits is the disturbance from lightning. In addition to the lightning

protection afforded by arresters in power stations and substations, arresters are sometimes installed along the line. Such an arrangement is shown in Fig. 36. Here a grounded wire is placed near the transmission line to afford a path for the lightning to ground across a short air gap. The wire is bent like a horn (suggesting the usual name of "horn" arrester) so that the arc which may follow the lightning discharge may be ruptured automatically. This it does because the hot vapors tend to rise and in doing so have to cross a lengthening path which finally is too long to permit the arc to hold.* Fig. 37 is an arrangement suggested by an association of insurance companies for protecting a building into which a line enters. Additional safety is secured by the use of a small detached arrester house.

Conduit Line. Cables are placed underground in conduits of creosoted wood, of tile, of paper or of cement-lined iron pipe. For this purpose the conductor is heavily insulated with rubber or with paper or jute impregnated with a mineral wax compound. To prevent entrance of water, such wire is almost invariably lead covered. The conduit is preferably laid in concrete to insure solidity of joints and permanence of grade. Conduits are built with any desired number of ducts, and they are continuous and usually straight between manholes located at such distances as to permit easy drawing in and removal of cables. About 500 feet is an average distance between manholes. Manholes are located at branch points so that joints may be easily made and repaired.

Indoor Circuits. Indoor wiring comprises two general classes:

- (a) Open or exposed, and
- (b) Concealed.

* The general principles underlying lightning arresters are discussed in Chapter IX, as they naturally form a part of station equipment.

The latter may also be subdivided into

1. Knob and tube,
2. Conduit (lined or unlined),
3. Molding.

The insurance rules regulate interior wiring almost entirely and the wiring of any insured building must be inspected

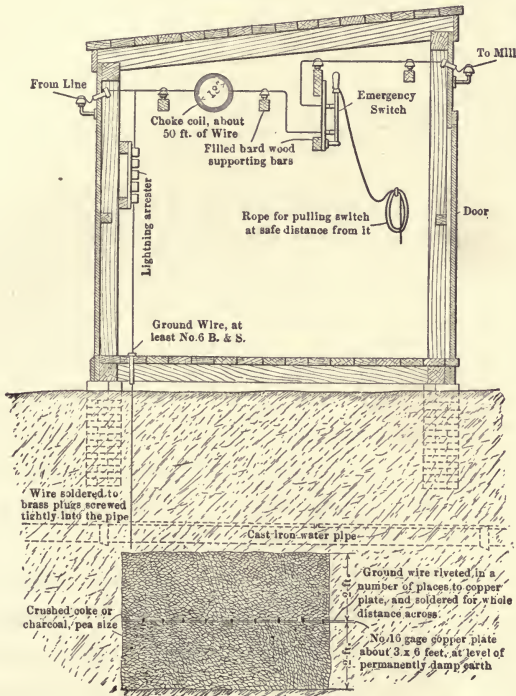

FIG. 37. Lightning arrester house for use at service connection with moderate line e. m. f. (from hand-book Associated Fire Ins. Assn.)

when installed and is liable to inspection and condemnation at any time.

Open wiring is the cheapest form of work and it is largely used in mill work and to some extent for residences. It

possesses advantages also in the ease with which it may be inspected and repaired and the readiness with which it may be modified to meet changing conditions. The wires are supported upon knobs and cleats.

Concealed knob-and-tube wiring is the type usually used for residences. It is also inexpensive and has the advantage of being entirely invisible. It is possible to change this wiring to a limited extent. The name is derived from the use of knobs which support the wires in the wall and ceiling spans and the tubes through which the wire is drawn to protect it from wood-work, pipes, and other possible sources of "grounds."

Conduit wiring is the safest but most expensive of all classes of wiring. In common with the former class it may be concealed in walls, under ceilings and floors. The conduit is, however, not always concealed but is frequently used in exposed locations when special safety is desired. This is considered almost necessary in damp locations. Conduit wiring is permanent and this feature will frequently offset the increased cost. On the other hand, it is not a flexible system as it is almost impossible to change the location of outlets after they have once been installed.

Conduits are made fire-tight so that the effects of any short-circuit may be confined to the tube or fittings. These are also to a limited extent water-tight. Mechanical continuity is assured by the Code provision that the wires shall be drawn into conduits only after the installation of the latter is complete. Electrical continuity of the conduit system is essential as great reliance is placed on grounding to eliminate fire risk from leakage of current to ground through high resistance.

Molding work is cheap and is fairly well protected. It is easily installed in old buildings. It is rapidly going out of

favor and will, in time, be entirely displaced by the more modern methods.

Design and Operation of Electric Circuits.

The electric circuit is analogous to a belt transmitting power, the velocity of the belt corresponding roughly to the current and the tension to the pressure. For the transfer of power the circuit must be complete, which it may be in one or more of the following ways:

1. *Through a conductor.*

In this case the energy of the current is all dissipated in heat unless some part of the conductor is the seat of an electric pressure, when it will come under case 3.

2. *Through an electrolyte and a conductor.*

Here all of the energy of the current produces chemical dissociation in the electrolyte, except that portion lost as heat in the conductor. The dissociation is accompanied by the presence of a counter-pressure in the electrolyte.

3. *Through a motor and a conductor.*

In a motor the transformation of electrical into mechanical power is accompanied by the production of a counter-pressure.

4. *Through a dielectric and a conductor.*

If a dielectric forms part of an electric circuit a current will flow through the circuit until the dielectric produces a counter-pressure exactly equal to the line pressure. In order to maintain a continuous flow of current through such a circuit, either an alternating pressure must be used or the direction of connection of the dielectric in the circuit must be periodically reversed.

It will be noted from the preceding statements that, except in the production of heat, the transformation from electrical

into some other form of energy is accompanied by the presence of a counter-pressure, which is the evidence of a resistance to the change of form. In case of heat there is no such resistance, as heat is the lowest form of energy and the more highly organized forms tend, therefore, to reduce to heat.

In this chapter attention will be confined to the transmission part of the circuit, leaving the other parts for their appropriate chapters. The function of the electric circuit is to transmit power from the generator to the receiver with maximum economy and satisfactory regulation of e. m. f. By maximum economy is not necessarily meant the highest efficiency, for beyond a certain point it does not pay to increase efficiency as the value of energy saved is more than offset by the extra cost of line and maintenance. Satisfactory regulation of e. m. f. is determined by the nature of the apparatus used and the purpose for which it is employed. An incandescent lighting circuit must have excellent regulation as the lamps are very sensitive to changes in e. m. f. Motor service need not be as good, as motors perform well on a reasonable range of e. m. f. Different classes of motor application impose various restrictions on this range, which can be large for railway service, say 20 per cent, while for shop drive 5 per cent would be a reasonable allowance. The variety of current also has an important influence upon the performance of the line.

Varieties of Current. A primary or secondary battery gives a current which is always in the same direction, and which is called, therefore, a *direct* or more properly a *continuous* current. This current is not only continuous, but it does not vary materially from instant to instant. Other forms of apparatus yield current which is also unidirectional but which fluctuates considerably and rapidly in value. This



variety may be conveniently termed *pulsating* current. The most common form of current is one which alternates in direction very rapidly and which is therefore named an *alternating* current.

In direct current work and in some cases in which alternating current is used a circuit is designed on the basis of carrying capacity of conductors and resistance drop. For example, if a 25 H. P., 500 volt D. C. motor is to be operated 500 feet from the generator with a 5 per cent drop in e.m. f., a wire will be selected of such size that 1000 feet of it do not cause more than 25 volts drop with the full load current, in this case about 50 amperes. The wire may have a resistance of one-half ohm per thousand feet. By reference to the wire table, it appears that a No. 7 B. and S. wire fulfils the requirements as far as its resistance is concerned. The carrying capacity of this wire is satisfactory in accordance with allowance for weather-proof wire in the table given in the National Electrical Code.

Alternating Current Circuits. In alternating current circuits it is necessary in general to consider the performance of the line with reference to all of its properties, in each special case neglecting those which have no appreciable effect. In Chapter II the fundamental quantities in the electric circuit were described and defined. It was shown that there are three and only three properties of a circuit, namely:

- (a) Resistance, analogous to mechanical resistance.
- (b) Inductance, analogous to mechanical inertia.
- (c) Capacity, analogous to mechanical elasticity.

Before noting the particular effects of each of these properties upon the operation of the circuit a review of the subject of alternating quantities from a familiar example will greatly simplify the subject.

Alternating Quantities in the Steam Engine. Any alternating quantity is one which periodically reverses its direction, reaching equal positive and negative maximum values. By adapting the apparatus to the nature of these alternating quantities, continuous effects may be produced. A familiar example of this is found in the steam engine where the alternating pressure on the piston is made to produce continuous rotation of the main shaft. The steam engine is so nearly analogous to electrical apparatus that it may be used as the starting point in this discussion. Fig. 38 shows the familiar

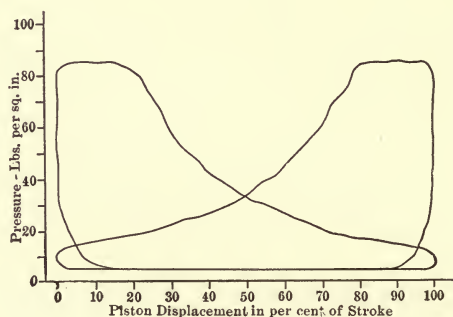

FIG. 38. Steam engine indicator card on displacement base.

steam engine indicator card with pressures for ordinates and piston displacements for abscissæ. The left hand card represents one end of the cylinder, the right hand card the other. The upper part of each card is that representing the production of power, while the lower part, the back pressure line, shows work done by the piston in driving the exhaust steam out of the cylinder. In Fig. 39 the diagram has been redrawn in the form usual in plotting periodic curves and the net pressure line is the only one shown. This is obtained by subtracting the back pressure from the forward pressure. For convenience, pressures in one direction, e.g., toward the

crank end of the cylinder, are drawn above the zero line and those toward the head end below it. The net pressure exerted by the piston is now in graphical alternating form and is

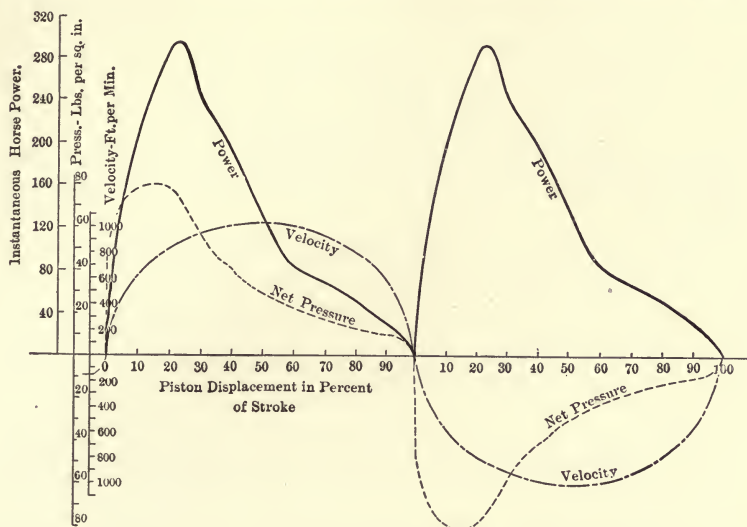

FIG. 39. Steam engine pressure, velocity and power diagram, showing alternating nature of steam pressure and piston velocity.

closely analogous to an alternating pressure or e. m. f. in an electric circuit.

The piston velocity at each point in the stroke may also be plotted on the same displacement base and its relation to the pressure determined. From Fig. 40 it is evident that the piston velocity is proportional to the sine of the angle between a horizontal line and a line through the center of the shaft and the center of the crank pin, assuming an infinitely long connecting rod. The velocity line will then have the form shown in Fig. 39 and it is an alternating quantity.

The power, which is being developed by the piston at any value of the displacement, is found by multiplying together the pressure and velocity ordinates. When these are in the

same direction, as is always the case in this illustration, their product represents an output of power. If they were in opposite directions the product would represent an absorption

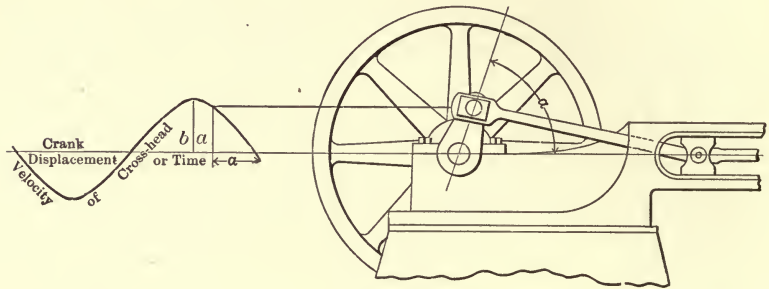

FIG. 40. Diagram showing relation of cross-head velocity of steam engine to annular velocity of crank.

of power from an outside source. The power line is shown in Fig. (39) and this is not an alternating quantity for the power is given out as long as the net pressure and the velocity are in the same direction.

The indicator cards of Fig. 38 were plotted by the indicator on a displacement base on account of the mechanism employed. That is, the steam engine indicator is operated by a reducing gear from the cross-head. If it were desirable, for any reason, the diagrams could be redrawn on a time base. As the crank rotates at a uniform angular velocity, the angle between the crank line and the reference line is proportional to the time, hence the displacement values may be readily transformed into time values. This would put the alternating velocity and pressure in the form usually employed for electrical quantities, but it is not necessary to use this form in the case of the steam engine.

It is desirable to give names to the different parts of an alternating quantity for convenience in reference.

The series of values of an alternating quantity between positive and negative maxima constitute an *Alternation* and two successive alternations, a *Cycle*. The time of a cycle is a *Period* and the number of cycles or alternations in a given time is the *Frequency*. The two common forms of frequency are cycles per second (often written p. p. s. as an abbreviation for periods per second) and alternations per minute. Commercial frequencies range from 15 to 133 cycles per second in engineering practice.

Alternating E. M. F. and Current. As the conductors of the armature of an electric generator pass under successive north and south poles they generate e. m. f. first in one direction, then in the other. In other words, the natural e. m. f. of practically all electric generators is alternating. Unless supplied with a device for changing it to unidirectional form the e. m. f. appears in the circuit in its natural form.

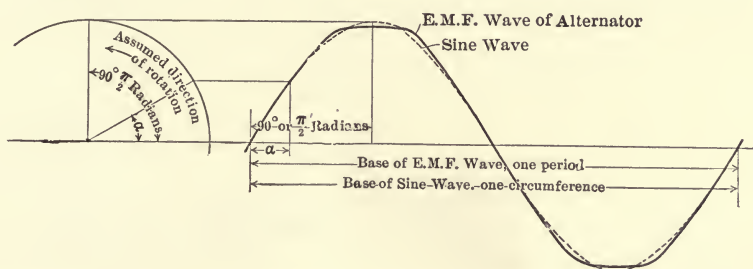

FIG. 41. E. m. f. curve of alternator on time base super-imposed upon sine wave on angle base, showing their similarity.

If the successive e. m. f. values of an A. C. generator be plotted upon a time base they might produce the curve shown in Fig. 41. While the e. m. f. from different alternators varies somewhat in form, being sometimes more peaked, often flatter than shown, this curve may be taken as an average

one. It is evident at a glance that this curve is strikingly like a sine curve in form. To emphasize the similarity, a sine curve with its base equal to one-half cycle of the e. m. f. is superimposed upon the e. m. f. curve. So close is this similarity that in general the e. m. f. curve of an alternator may be assumed to be of the sine form, and a sine curve may replace it, the angle ordinates of the base of the sine curve replacing the time ordinates of the wave. This is the reason that in the literature of electrical engineering electrical quantities are often referred to an angle base. This is entirely conventional and is possible through the coincidence referred to.

Effective Values of Alternating Quantities. As it is essential that alternating e. m. f. and current be measured and compared with direct current and e. m. f., it is necessary to select some value of these quantities which shall be suited to this purpose. Naturally such values have been chosen that an alternating current ampere is that current which will heat a

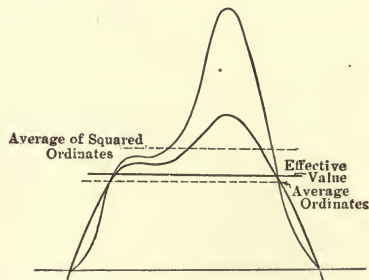

FIG. 42. Current wave and square of same, showing derivation of "effective" value of an alternating quantity.

wire to the same extent as will an ampere of continuous current. An incandescent lamp supplied with an ampere of alternating current will therefore give out the same amount of light as with an ampere of continuous current. An effective

alternating volt is such an e. m. f. that, impressed upon the terminals of a circuit containing resistance only, that circuit would be heated to the same extent as it would have been by a continuous volt. An effective alternating volt will send an effective alternating ampere through one ohm of resistance. From Joule's law the heating value of a current is proportional to its square, hence the effective value of an alternating quantity will not be the same as the average value. In Fig. 42 is shown a wave of current and its average value. The curve of the squares of the current values with its average is also shown and this indicates the instantaneous and average rates at which heat is produced in the circuit. Obviously the square of the average current will not be the same as the average of the squares. The square root of the average of the squared curve is termed the *effective value*. It is always more than the average value, being greater for peaked waves and less for flat-topped ones. In the case of the sine wave the effective value is 11 per cent greater than the average. The maximum value is $\frac{\pi}{2}$ times the average value and the effective value is $\frac{1}{\sqrt{2}}$ times the maximum value.

Alternating Current Power. The power in an alternating current circuit is the product of the current and e. m. f. at any instant. The average power, which would be shown by a watt-meter, is the average of the instantaneous values. The product of the effective alternating volts and amperes is not necessarily the power of the circuit, for it is possible that the maximum values of current and e. m. f. may not occur at the same time. In fact, when the two have the same frequency, as is generally the case, it may happen that one will be always zero when the other is maximum and the average power

would then be zero. The quantity by which the product of effective e. m. f. and current in a circuit must be multiplied, in order to give watts developed, is called the *Power Factor*.

$$\text{P. F.} = \frac{\text{watts}}{\text{volts} \times \text{amperes}}$$

To determine the power factor of a circuit with ordinary instruments requires measurements of watts, volts, and amperes. The expression $\cos\theta$, frequently used in place of power factor applies only to sine waves and is explained in the next section under "phase displacement."

Phase Displacement of Alternating Quantities. When two waves of the same frequency do not reach their zero and maximum values at the same time they are said to be *out of phase*, otherwise they are *in phase*. For example, if the e. m. f. in a circuit reaches its maximum value a certain fraction of a period before the current it *leads* the current by that amount or more commonly by the equivalent angle as explained in a previous paragraph. Fig. 43 illustrates this. The sine e. m. f.

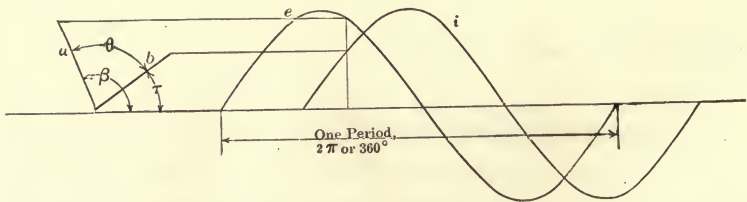

FIG. 43. Diagram illustrating meaning of the term "phase displacement."

wave e would be generated by a rotating radius a , the ordinates being the projections of a upon the vertical axis and the abscissæ being the values of the angle β between a and the horizontal axis. Similarly the current wave i would be generated by a second radius b making an angle τ with the horizontal axis.

The difference in phase of e and i , therefore, may be conveniently referred to as the difference between the angles β and τ . This angle is usually called θ and, with sine waves of e. m. f. and current, $\cos \theta$ is the power factor.

Problems Illustrating the Definition of Power Factor.

In a transmission circuit at 60,000 volts pressure a current of 50 amperes is flowing. The watt-meter indicates 2500 K. W. What is the power factor and what the phase difference of e. m. f. and current?

Ans. 83.3 per cent.

$\theta = 33.5$ degrees.

How many amperes will be required in a 6,600 volt circuit to produce 50 K. W. when the current lags 10 degrees behind the e. m. f.?

Ans. 7.69 amperes.

Polyphase Circuits. When two or more circuits are used in combination and the e. m. f.'s in these are of the same frequency, but differ in phase position, the system is called a *polyphase circuit*. Obviously, a single two-wire circuit is a *single-phase circuit*. For example, in Fig. 44 are two circuits

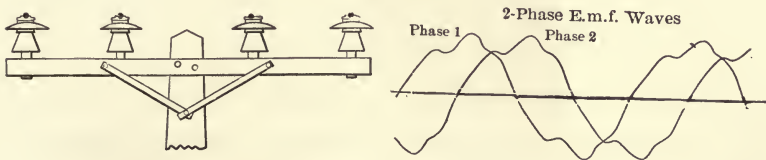

FIG. 44. Two-phase transmission line and diagram of e. m. f. waves in the two circuits.

in which the e. m. f.'s differ by a quarter period or 90 degrees. This is a two-phase or quarter-phase circuit and all apparatus designed to employ such a circuit is two-phase apparatus,

e.g., a two-phase motor. In this case the two circuits are separate single-phase circuits but their e. m. f.'s always preserve a definite phase relation.

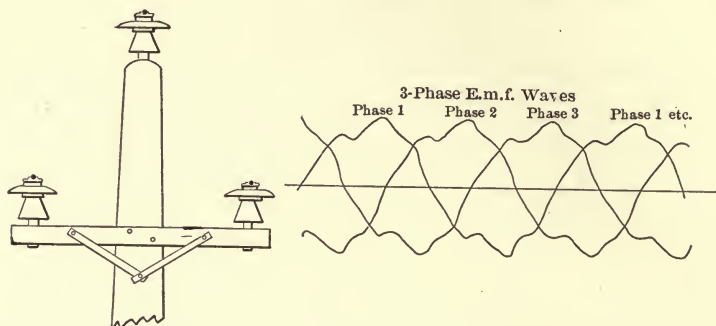

FIG. 45. Three-phase transmission line and diagram of e. m. f. waves in the three circuits.

Fig. 45 shows a corresponding three-phase system employing three wires. The e. m. f.'s between adjacent wires are 120 degrees apart. This is the arrangement used for practically all long distance power transmission. Four wires may be used for four circuits, the phase difference between

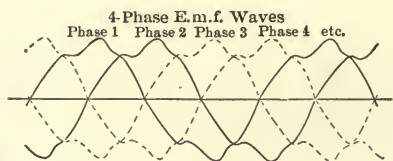

FIG. 46. Diagram showing the e. m. f. waves in the four circuits of a four-phase system.

adjacent circuits being 90 degrees. Six wires and six circuits with adjacent phase displacements of 60 degrees, forming a six-phase circuit, are also occasionally used. For most purposes, however, two or three phases are sufficient.

The reasons for the use of polyphase systems rather than single-phase are that (1) they are more economical of copper and (2) polyphase apparatus is more efficient and satisfactory than single-phase.

Resistance, Inductance and Capacity in Electric Circuits.

The properties of electric circuits were briefly discussed and units defined in Chapter II. These definitions may now be applied to the flow of current in alternating current circuits and their mechanical analogies will be useful in indicating the manner in which they affect the performance of a circuit. *Resistance* is analogous to mechanical resistance, *inductance* is analogous to inertia, and *capacity* is analogous to elasticity.

Resistance consumes e. m. f. in direct proportion to the current, hence a wave of resistance-consumed e. m. f. will be in phase with the current. In algebraic form, $E_R = RI$. This is shown in Fig. 47 where a current wave is given and this current is to be sent through a circuit of 700 ohms resistance. The e. m. f. curve has been calculated point-by-point by multiplying together the current in amperes and resistance in ohms.

Inductance consumes e. m. f. in proportion to the rate of change of the current just as inertia produces force in proportion to the rate of change of velocity. i. e., $e_L = -L \frac{di}{dt}$.

This is marked minus to indicate that the e. m. f. generated in the inductance *opposes* a change in the current. In order to change a current in a circuit in which there is inductance, it is necessary to introduce an e. m. f. equal and opposite to the self-induced e. m. f., or $e = +L \frac{di}{dt}$.

In Fig. 47 the wave of e. m. f. which would be generated by sending the wave of current through a circuit has been plotted

by noting the rate of change of current for a number of different ordinates. By measuring the changes in current

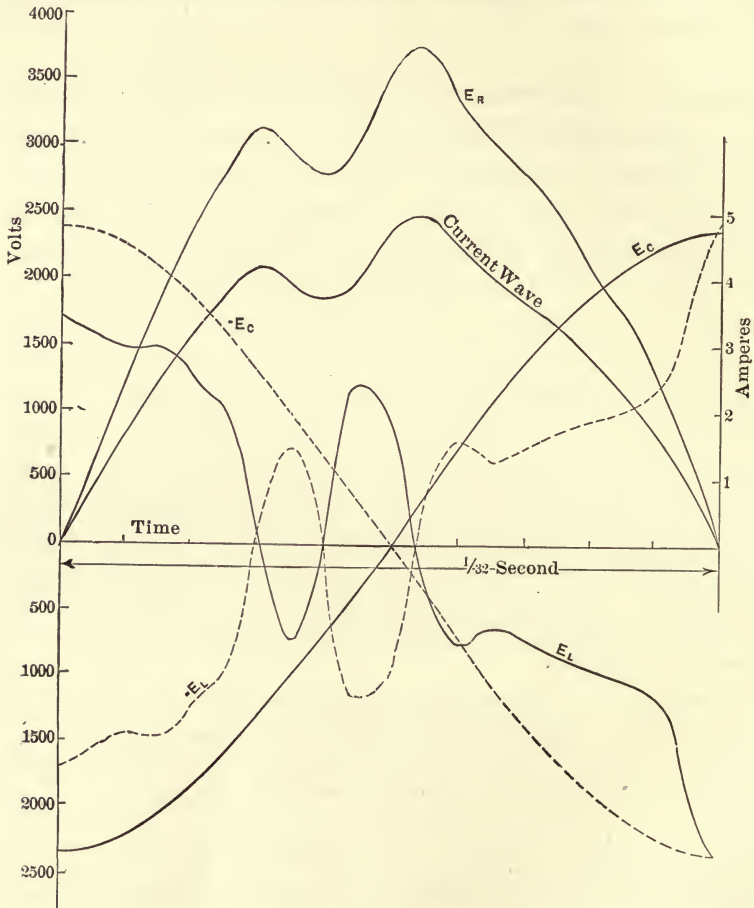

FIG. 47. Diagram showing the e. m. f. waves necessary to send a given current wave through 700 ohms res., 3 henrys inductance, and 20 m. f. capacity.

during short intervals of time and dividing these by the time intervals, the average rates of change, corresponding to the

mean times, are obtained. These rates of change, in amperes per second, are multiplied by the inductance in henrys (3 in this case) to determine the volts generated. To produce these rates of change of current in the circuit requires an e. m. f. wave equal and opposite to that produced in the circuit, as shown by the solid line E_L .

Capacity in a circuit results in a flow of current proportional to the rate of change of the applied e. m. f., just as in elastic bodies the rate of deformation is proportional to that of the applied pressure. As long as the e. m. f. is changing the current flows, and the e. m. f. is proportional at any instant to the total quantity of electricity that has flowed into the dielectric. As the quantity is the product of current and time, the e. m. f. due to capacity at any instant is proportional to the time-integral of the current. In algebraic form,

$$e = + \frac{I}{c} \int idt.$$

The positive sign here indicates that the e. m. f. due to capacity resists the *flow of the current*, whereas that of inductance resists a *change* in it.

In Fig. 47 is shown a wave of e. m. f. produced by the capacity in a circuit. It is calculated by integrating the current wave from its intersection with the horizontal axis to a number of successive ordinates. The area of the current wave is the total quantity of electricity which has flowed out of or into the condenser. When the current is zero no charge is passing into the dielectric and the quantity of charge is maximum because the e. m. f. is maximum. The first step, therefore, is to calculate the quantity of electricity in the dielectric at the maximum e. m. f. by multiplying this e. m. f. by the capacity in farads (in this case 20 microfarads, or millionths of farads). Then as successive areas are meas-

ured the corresponding quantities of electricity are subtracted one by one until the remainder is zero. At this point the e. m. f. is zero and its intersection with the horizontal axis has been determined. Beyond this point the quantities of electricity corresponding to the successive areas are added, and when complete should indicate the same quantity as at the start, for the positive and negative maxima of e. m. f. are the same.

The e. m. f. wave necessary to maintain the given current wave through the dielectric, as shown by the solid line E_c , will be the reverse of that produced in the dielectric, or

$$e = -\frac{1}{c} \int i dt.$$

If the same current flows successively through the resistance, inductance and capacity, that is, if they are *in series*, the several required e. m. f.'s must be added, point by point, to determine the wave of total e. m. f. which will be necessary.

Reactance and Impedance. Referring once more to Fig. 47 it is evident that there must be a relation between the effective values of the e. m. f. and current in each of the three cases cited. This ratio, in the case of the resistance circuit, is simply the resistance, for the form of the e. m. f. wave is the same no matter what the frequency of the circuit may be. This is not true of the other circuits. In the inductive circuit the e. m. f. is greater with a greater frequency (smaller period) while the reverse is true of the capacity circuit. *The name reactance is given to the ratio of the effective values of e. m. f. and current in these cases. Inductive reactance and capacity reactance are the ordinary terms employed. Reactance like resistance is measured in ohms.*

If both reactance and resistance are present in a circuit, the ratio of the effective value of the total e. m. f. consumed

to that of the current is the *impedance*, which is also measured in ohms.

Up to this point nothing has been said of the sine wave, and all the statements made apply to any form of wave. If sine waves be used or assumed the reactance and impedance may be conveniently expressed algebraically, otherwise they may not. The sine curve has a property very useful in electrical work, namely, that *its derivative is also a sine wave*, a quarter period, or 90° in phase position from the original. Then the reactive e. m. f.'s in inductance and capacity are in quadrature with the current, one behind, the other ahead. Further, the sum of the sine waves (with the same length of base) is also a sine wave and its maximum value is the geometric sum of the maximum values of the components as indicated in Fig. 48.

If in Fig. 47 the current wave had been of the sine form, the e. m. f. waves would have been sine curves. The effective value of the inductive e. m. f. would have been $2 \pi f L$ times

Inductive circuit.

$$e_L = L \frac{di}{dt} \qquad i = i_{max} \sin 2 \pi f t$$

where $2 \pi f$ is the angular velocity of a rotating radius which would generate the current curve, and e_L is the e. m. f. necessary to force the current through the circuit.

$$\begin{aligned} di &= i_{max} 2 \pi f \cos 2 \pi f t, \\ \frac{di}{dt} &= i_{max} 2 \pi f \cos 2 \pi f t, \\ e_L &= i_{max} 2 \pi f L \cos 2 \pi f t. \end{aligned}$$

As the coefficient, $i_{max} 2 \pi f L$, is the maximum e. m. f. (maximum ordinate of the cosine curve), the ratio of the e. m. f. and current is $2 \pi f L$. This is the reactance of the circuit.

Capacity circuit.

$$\begin{aligned} e_C &= \frac{1}{C} \int i dt & i &= i_{max} \sin 2 \pi f t, \\ \int i dt &= -\frac{i_{max}}{2 \pi f} \cos 2 \pi f t, & e_C &= -\frac{i_{max}}{2 \pi f C} \cos 2 \pi f t. \end{aligned}$$

As the coefficient, $\frac{i_{max}}{2 \pi f C}$, is the maximum e. m. f., the ratio of e. m. f. and current is $\frac{1}{2 \pi f C}$. This is the reactance of the circuit.

that of the current, and that of the capacity e. m. f. would have been $\frac{I}{2\pi fC}$ times that of the current. Hence these quantities represent the reactances in circuits containing induct-

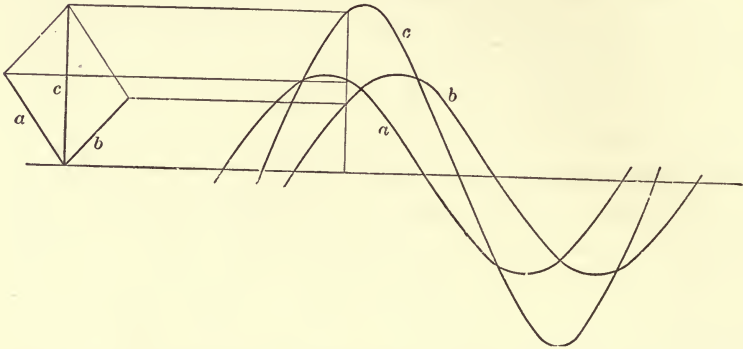

FIG. 48. Diagram representing the addition of sine waves.

ance and capacity. The impedances in such circuits are the geometrical sums of the resistance and reactance, and as the e. m. f.'s are in quadrature the resistance and reactance are combined by the law of squares, thus, $e_z = \sqrt{e_L^2 + e_R^2}$.

Problems Illustrating the Definitions of Reactance and Impedance.

A transmission line has a resistance of 50 ohms and an inductive reactance of 250 ohms. What are the drops in resistance and reactance and the total drop in the line and what is the e. m. f. at the receiver end if the generator e. m. f. is 50,000 volts, the current 25 amperes and the load power factor, 100 per cent?

Ans. 1250 volts. 6250 volts. 6375 volts. 48,348 volts.

The charging current on a cable system is 10 amperes at 20,000 volts, 60 cycles. What is its capacity assuming sine form current?

Ans. 1.326 microfarads.

Practical Applications. In direct current circuits inductance and capacity are of comparatively little importance. In alternating current work where the e. m. f. and current change values rapidly, the effects of these quantities must always be considered. Take for example, a transmission line. The wires are supported in the air and each is surrounded by a magnetic field. While this field is not very strong the wire is so long that the total quantity of flux is considerable. In fact it may produce several thousand volts pressure in a line like that from Niagara Falls to Syracuse. Further, the conductors are separated by a dielectric, air, and there is a considerable capacity on account of the great length of line. This results in a flow of current into the line even when no apparatus is connected to it. This "charging current" often is a considerable percentage of the useful current in the line. The magnetic field and the dielectric absorb very little power as they give back to the line practically all that they receive, but the presence of the *inductive drop* and the *charging current* have an important bearing upon the performance of the line.

CHAPTER V. MAGNETIC CIRCUITS.

OUTLINE.

Illustrations of Practical Magnetic Circuits: Street railway motor — magnetic brake — transformer core.

Laws of the Magnetic Circuit: Tractive effort.

Excitation of Electro-Magnets: Reluctance — magnetic leakage — problem of the magnetic brake.

Excitation of Magnetic Circuits in Electrical Machinery: The transformer — electric generators and motors. Excitation by permanent magnets: From separate exciter — by shunt winding — by series winding — by compound winding.

A MAGNETIC CIRCUIT is the path of magnetic flux in a piece of electrical or magnetic apparatus. The greater portion of such a circuit is usually magnetic material, but there are fre-

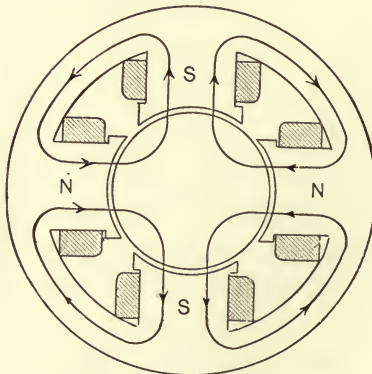

FIG. 49. Diagram representing the magnetic circuits of a street railway motor, showing the field coils in section.

quently one or more air gaps in the circuit. Usually the magnetomotive force is supplied by coils of wire carrying current, but occasionally in electrical devices hard permanently magnetized steel is used.

Illustrations of Practical Magnetic Circuits.

Fig. 49 shows in diagram the magnetic circuits of a *street railway motor*. There are four paths for the magnetic flux, hence there are four magnetic circuits as indicated by the arrow-headed lines. In each magnetic circuit there are two

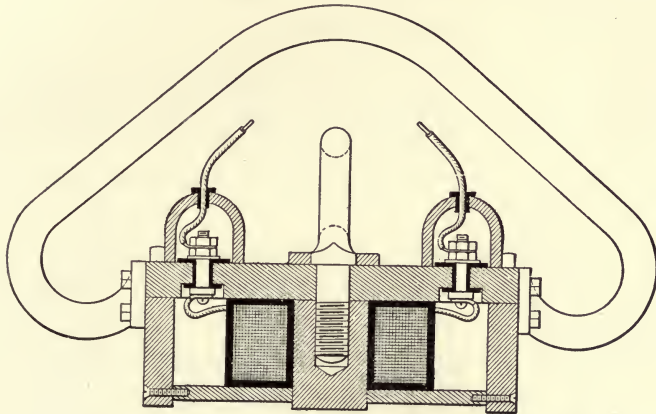

FIG. 50. Cross-section of a lifting magnet such as is used for lifting heavy safes, etc. (El. Controller & Supply Co.)

pole pieces, two air gaps, one section of armature core and one section of yoke or case. The m. m. f. is supplied by field coils mounted upon the pole pieces and so connected as to produce north and south poles alternately. The function of this particular magnetic circuit is to produce flux in the air gaps against which the current in the armature conductors may react and produce torque.

A second illustration of a magnetic circuit, one designed as a *lifting magnet*, is given in Fig. 50. A magnet of this kind,

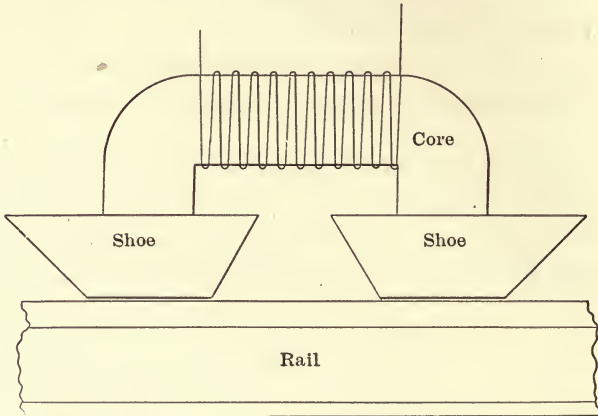

FIG. 51. Diagram of Westinghouse magnetic brake, showing several parts of the magnetic circuit.

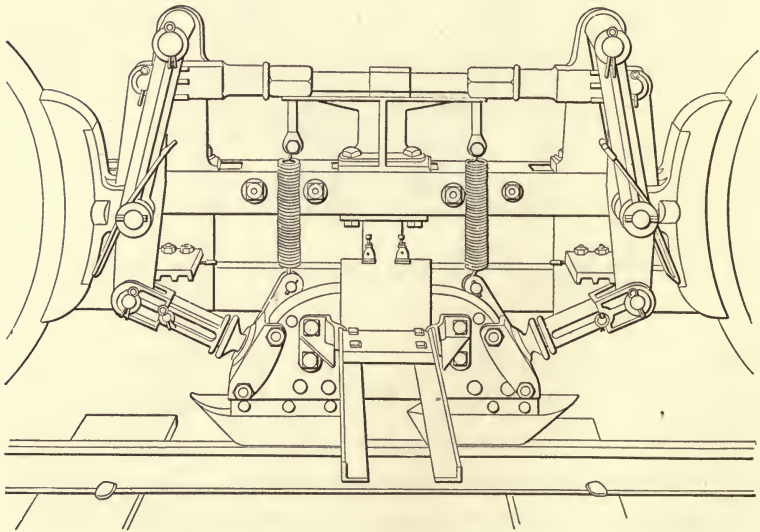

FIG. 52. View of the Westinghouse magnetic brake of which Fig. 51 is a diagram.

supported from a crane, is capable of handling rails, plate, scrap, nails and many other iron products very conveniently. The magnetic circuit is through the pole piece, top plate, side plates, air gaps and section of the object lifted. The air gaps exist because it is impossible to produce perfect contact between the poles and the lifted object.

A third illustration of a magnetic circuit is shown in Figs. 51 and 52, which represent a *magnetic brake* used to a limited extent on street railway cars. The brake consists of a horse-shoe shaped electro-magnet, flexibly supported, which is drawn into contact with the rails when current is supplied to the coil. When the magnet is in contact with the rails, the motion of the car produces a backward pull which is transmitted to the wheel brakes through a lever system. The magnetic circuit is through the magnet core, air gaps, and rail.

Another class of magnetic circuit is found in the *alternating current transformer* where there is no air gap in the circuit. Fig. 53 shows a transformer core in which the path of the flux is around the rectangular frame. The function of the flux in this case is to produce e. m. f. when the current, which sets it up, is changed in value, just as in Faraday's ring of which it is an improved copy.

The illustrations will serve to indicate several of the modes of application of the electro-magnet and its prevalence in electrical machinery. In fact, there are few devices in which the magnet is not an important part.

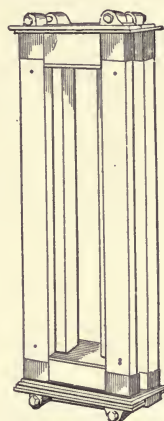

FIG. 53.
Core of a type H, (G. E. Co.) transformer. A simple, typical magnetic circuit. Cross-section is cross-shaped to permit circulation of cooling oil.

Laws of the Magnetic Circuit.

In these applications there are three functions of the magnetic flux:

(a) To produce e. m. f. in conductors moving through it, or otherwise cutting it, e.g., in the electrical generator and the transformer.

(b) To produce force upon conductors carrying current and located in it, e.g., electric motors of all kinds.

(c) To produce mechanical pull between the poles and attracted objects, e.g., the lifting and brake magnets described in this chapter.

The laws underlying (a) and (b) have been illustrated in Chapter II. The mechanical attraction depends upon the flux density in the field and upon the area of its cross-section. Experiment shows that the pull is exerted in accordance with the following formula:

$$F = A \frac{B^2}{8\pi}$$

where F = the force in dynes (445,000 being approximately equal to a pound).

A = the area in square centimeters.

B = the flux density in maxwells per square centimeter.

Problem Illustrating the Pulling Strength of a Magnetic Field.

In the magnetic brake shown in Figs. (51) and (52) the cross-section of each air gap is 9 square inches. When the current is first turned on and the air gap has its maximum length the pull is 88 pounds. When the shoes have been pulled against the rail the pull increases to 1248 pounds. What flux in maxwells per square inches exists in each case?

Ans. 18,800 maxwells per square inch.

70,600 maxwells per square inch.

Excitation of Electro-Magnets.

In Chapter III the relations between the m. m. f. required to maintain flux in various materials was exhibited graphically by means of the B-H curves. To determine the number of ampere-turns necessary to maintain a desired flux at any portion of a magnetic circuit the ampere-turns required in the several parts of the circuit are calculated separately and added together. The ampere-turns required in the air gaps may be determined directly from their areas normal to the direction of the flux and their lengths in its direction. An ampere-turn produces 1.257 ($0.4 \times \pi$) gilberts. A gilbert will set up a field of an intensity of a gauss in a centimeter length of circuit in air. The m. m. f. required is proportional to the intensity or flux density and to the length of the circuit. For example, take a density of 60,000 maxwells per square inch to be set up in a generator air gap one quarter inch long (measured radially or in the direction of the flux). The intensity of the field is 9320 gauss corresponding to 9320 maxwells per square centimeter. Nine thousand three hundred and twenty gilberts are, therefore, required for each centimeter length of circuit in air. The circuit is 0.635 centimeters long, and the gilberts required are 9320 times 0.635 or 5920. Each ampere-turn produces 1.257 gilberts, so that 4715 ampere-turns will maintain the required flux density of 60,000 maxwells per square inch.

The ratio of the total m. m. f. in gilberts to the total flux produced is called the *reluctance*. While this quantity is not used extensively in electro-magnetic calculations it is convenient as it is somewhat analogous to electrical resistance. The reluctance of any one part of the circuit is,

$$\mathcal{R} = \frac{l}{A \mu}.$$

\mathcal{R} , reluctance; l , length; A , area; μ , permeability.

Reluctance differs from resistance in that it is not constant but varies with μ which is affected by the flux density. It will be noted that μ corresponds in the formula to the reciprocal of specific resistance in an electric conductor.

Magnetic Leakage. If the flux were entirely confined to its proper paths *the total flux at all cross-sections of the circuit would be the same.* There is some leakage, however, through the air, the amount of which can only be determined for any case by experiment. It is this leakage flux which affects watch springs in the neighborhood of electric generators. The leakage is greatest when the air gaps are long and amounts to very little when there are no air gaps in the circuit.

Problem Illustrating the Method of Calculating Exciting Current for Electro-Magnets.

In the magnetic brake shown in Figs. 51 and 52 a pull of about 1250 pounds between shoes and rail is desired, when the brake shoes are in contact with the rail. With the following data given determine the current necessary to give the required pull:

Part of Circuit.	Material.	Length.	Cross-section.
		Inches.	Square Inches.
Magnet core	Sheet steel (good)	18	11
Pole shoes	Cast iron (good gray)	3.5	18
Double air gap * . .	Air	0.05	18
Rail	Steel (mild)	12	8.5

Number of turns in coil 12

* The air gap length is assumed at the given value, as it is impossible to produce perfect contact between shoes and rail. The area given is that of each air gap, the two being magnetically in series.

Solution:

The first step is to determine the flux density in all parts required. The pull of 1250 pounds is divided between two pole shoes, thus distributing the pull over 36 square inches, or 232.2 square centimeters. The pull per square centimeter is 5.38 pounds, or $5.38 \times 445,000 = 2,394,100$ dynes. Multiplying this by 8π and extracting the square root gives the density in maxwells per square centimeter which is approximately 7,760. Assuming no magnetic leakage in the circuit the following results are obtained:

Part of Circuit.	Amp. turns per in. from Figs. 29, 31 and 32.	Total amp. turns.
Magnet core	7.9	142
Pole shoes	90.9	318
Double air-gap	15,700	785
Rail	147.4	1,769

Grand total . . . 3,014.0

Dividing this by 12, the number of turns, the required current is found to be 251.2 amperes.

Ans. 251.2 Amperes.

Excitation in the Magnetic Circuits of Electric Machinery.

The Transformer. If one coil of a Faraday's ring be connected to an a. c. circuit and the other coil be left open, a current will flow into the first coil. The function of this current is to "excite" the core, or, in other words, to set up alternating flux in it. The current is known as the *exciting current* and it flows continually whether the second coil is

giving out current or not. When a current is drawn from the second coil, additional current is absorbed from the line by the first. The exciting current represents a waste of power, and the lighting companies use transformers with as small an exciting current as possible.

Electric Generators and Motors. There are five possible ways for producing the field excitation in electric generators and motors:

1. By permanent magnets.
2. By separate excitation.
3. By a shunt winding.
4. By a series winding.
5. By a compound winding.

Permanent Magnet Excitation need not be discussed, as permanent magnets are no longer used except for the fields of

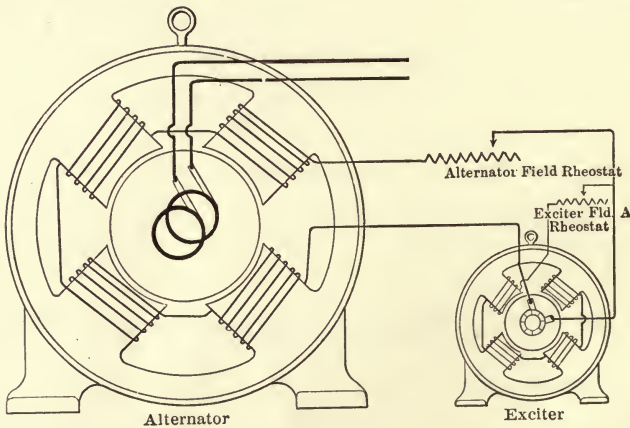

FIG. 54. Diagram of field excitation from separate exciter as used in alternator practice.

very small machines such as are used for ringing telephone bells.

Separate Excitation. By separate excitation is meant the supply of a current from an external source, such as another generator or a storage battery. Practically all alternators are separately excited, because, as the field requires a continuous current, that produced by the armature is useless for excitation. For this reason, an alternator is usually accompanied by a small machine known as the "exciter," which supplies the field current. In some cases a small commutator is connected with the armature to rectify enough current to supply the field, and this device takes the place of the exciter in some alternators. It is seldom necessary to excite a direct current generator separately, except for experimental purposes.

Shunt Excitation. The shunt winding is so named from the practice of "shunting" off a part of the armature current to excite the field magnets, the terminals of the field

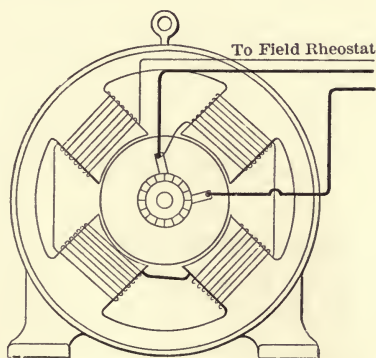

FIG. 55. Diagram of shunt field excitation as used in many d. c. generators and motors.

coils being connected directly to the brushes. For regulating purposes a resistance is usually connected in series with the field circuit so that its current may be varied, and the

e. m. f. of the armature adjusted over a considerable range. When a shunt machine is started from rest, there is no e. m. f. in the armature at first. There is, however, a slight residual field present and the rotation of the armature in this field produces some e. m. f. This small e. m. f. sends a current through the field circuit and increases the flux. Thus the machine "builds up" and the building up process continues until the saturation of the iron in the core reduces the rate of increase of the flux with the increase in field current. A point is reached at which the ampere-turns of the field maintain such a flux that the armature revolving in it generates the e. m. f. needed at the terminals of the field to produce the required number of ampere-turns. An increase in the speed will raise the e. m. f. more than proportionately, for as the e. m. f. of the armature increases with the speed, the field strength is increased unless the magnetic circuit is quite saturated, by the greater e. m. f. at the field terminals. Conversely, the e. m. f. decreases more rapidly than the speed, and below a certain critical speed the dynamo will not excite itself, for below this speed the e. m. f. produced by the armature is not sufficient to send enough current through the field circuit to produce the flux necessary to maintain it.

A simple laboratory experiment will serve to illustrate the above conditions. Suppose that a generator is driven at a certain speed and that the field is separately excited. Let the e. m. f. at the brushes and at the terminals of the field coil be measured. Evidently, if the e. m. f. at the brushes is less than that at the field terminals, the machine will not be self-exciting at that speed, and it is necessary either to run the armature at a higher speed or to increase the ampere-turns on the field by the use of a larger size of wire, having therefore a lower resistance.

Calculation of the Proper Size of Wire for a Shunt Field.

The flux required in the air gap determines the number of ampere-turns to be placed on the field to supply the necessary m. m. f. The e. m. f. at the brushes will have been previously determined, and this e. m. f. will be available at the terminals of the field circuit for sending the field current through it. The resistance of the field coils must be such that when the given e. m. f. is applied to its terminals such a current will flow that its product with the number of turns will give the required m. m. f.

The simplest method of solving this problem is to consider first that all the current flows through one turn of the field wire. This is allowable, for with a given size of wire the same number of ampere-turns will be produced, no matter what the number of turns, because the resistance of the coil increases in proportion to the number of turns and the current is thus reduced inversely as the number of turns is increased, keeping the product of the two the same. Assume, then, that the current flows through one turn, the length of which must be estimated from the dimensions of the magnetic circuit. The resistance of this one turn must be sufficient to allow a number of amperes to flow through it equal to the total number of ampere-turns. The resistance of this length of wire having been determined, the size of wire possessing it is selected from the wire table.

Obviously, this size of wire will not carry the current at first assumed, and it remains to determine how many turns of it will be necessary to reduce the current to a proper value. Each additional turn wound around the coil reduces the current that will flow without affecting materially the number of ampere-turns, until the coil becomes so bulky that the average length of a turn is increased beyond the original



estimate. It is never desirable to make the coil more than two or three inches in thickness, for beyond this it is difficult to dispose of the heat which forms in its interior and which is likely to injure the insulation if allowed to become excessive. The limit of the current depends on the heat radiating ability of the coil, which in turn is determined by the area exposed to the air and the temperature and circulation of the surrounding air. The allowable watts per square inch of radiating surface, or the square inches per watt, known as the *radiation factor*, allow for a certain rise in temperature at the surface of the coil, say 50 degrees C. When the number of watts which a given coil will radiate has been estimated, the number of turns may be increased with consequent reduction of current, until the watts lost in the coil, that is, the product of the resistance by the square of the current, are equal to its radiating ability.

In calculating the resistance of a coil it must be kept in mind that the resistance of almost all metals increases with the temperature, and, therefore, after a coil has been heated, its resistance is much higher than when cold. For this reason it is necessary to increase the value of the resistance as given by the tables, by an amount proportional to the rise of temperature which is expected to occur in the coil. This rise of temperature may be calculated from the temperature coefficient, which is the increase in resistance for a rise of one degree F. or C., as a proportion of the resistance at zero degrees C.

For example, if the resistance of a copper wire at zero degrees is 100 ohms, at 70° C. it is

$$(1 + 70 \times 0.004284) \times 100 = 130 \text{ ohms.}$$

*Problem Illustrating the Selection of Size of Wire for a
Field Coil.*

Given:

E. M. F. at terminals, volts.	100
Ampere-turns required	5000
Estimated length of one turn, ft.	2
Estimated radiating power, watts	250

Required:

The size of wire, the number of turns and the current.
Assume all the current to flow through one turn.

The resistance which allows 5000 amperes to flow through the circuit with a terminal e. m. f. of 100 volts is, from Ohm's law:

$$R = \frac{E}{I} = \frac{100}{5000} = .02 \text{ ohm,}$$

and this resistance is contained in two feet of wire. The resistance of 1000 feet (the quantity usually found in the tables) is

$$R = \left(\frac{1000}{2} \right) \times .02 = 10 \text{ ohms.}$$

which corresponds to No. 19 B. and S. (Brown and Sharpe) gauge (hot resistance).

To determine the number of turns needed:

The allowable power to be wasted is 250 watts, and this at 100 volts means a current of

$$I = P \div E = 250 \div 100 = 2.5 \text{ amperes,}$$

and the number of turns required is

$$n = 5000 \div 2.5 = 2000.$$

To check this result it may be noted that 2000 turns equals 4000 feet, having a resistance of $4 \times 10 = 40$ ohms. The energy lost is

$$P = I^2R = (2.5)^2 \times 40 = 250 \text{ watts.}$$

In this calculation no allowance has been made for a regulating resistance. In order to allow for such a resistance a wire larger than No. 19 would be used and the current would be controlled in value by this resistance, or field rheostat.

The Series Winding. The series winding is used principally for railway motors and for constant current generators. Of the latter comparatively few are used, and these only for arc lighting. In a series winding the wire is made large enough to carry the entire armature current, which is allowed to pass

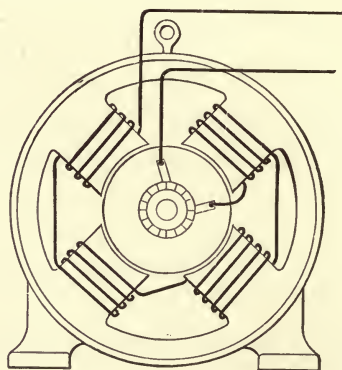

FIG. 56. Diagram of series field excitation as used in railway and other motors and in a few generators.

around the field in series with the armature. The excitation of the field is thus proportional to the current in the outside circuit, and at full load current the ampere-turns on the field should be sufficient to produce the required flux through the air gap.

Determination of the Size of Wire for a Series Field Coil.

As in the preceding case, the allowable loss of power is determined by the radiating ability of the coil, which depends upon the surface exposed. In this case the current which flows through the coil is given and a resistance may be chosen which will produce the allowable rate of heating with this current. The number of turns is also fixed by the required number of ampere-turns, being this number divided by the full load current of the armature.

Problem Illustrating the Selection of Wire for a Series Field Coil.

A series field coil will radiate 250 watts, and the full load current is 250 amperes. It must produce 5000 ampere-turns and the average length of turn is four feet. What is the allowable resistance and what size of wire is required?

The allowable resistance is, since $P = I^2R$,

$$R = P \div I^2 = 250 \div 250^2 = 0.004 \text{ ohm.}$$

The number of turns is

$5000 \div 250 = 20$ turns, and as the resistance of 20 turns is 0.004 ohm, that of one turn of four feet is

$$0.004 \div 20 = 0.0002 \text{ ohm.}$$

1000 feet will have a resistance of

$$\frac{0.0002}{4} \times 1000 = 0.05 \text{ ohm.}$$

From the wire table this is found to correspond to No. 0000 B. and S. gauge. As this is too large to wind, it may be either divided in several smaller wires, preferably square in form, or it may be made of one flat ribbon wound edgewise.

Compound Excitation. Shunt excitation of a generator does not produce as great an e. m. f. at the brushes when the machine is delivering a large current to the circuit as when it is on open circuit. This is due (1) to the loss of e. m. f. in the resistance of the armature; (2) this reduces the terminal e. m. f. and causes a further reduction, owing to the weakened field, which receives less magnetizing current when the e. m. f. at its terminals is reduced; (3) to the armature reaction which

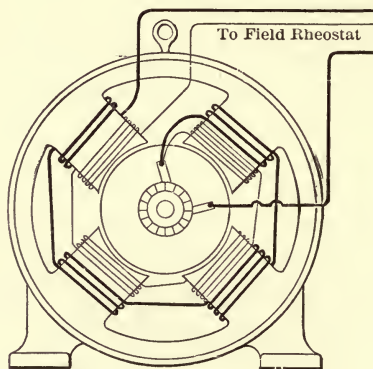

FIG. 57. Diagram of compound field excitation as used in most d. c. generators and in some d. c. motors.

occurs when the current flows through the armature, weakening the field to the extent of the number of back ampere-turns produced.

Series excitation results in a higher electromotive force for increase of load on the machine up to the limit of saturation of the field, as the field and armature currents are the same. It is possible, by combining the shunt and series excitation, to produce one that will maintain the same e. m. f. at full load and no load, or if desirable the armature may supply a greater e. m. f. at full load.

Estimation of Series Turns Required for Compounding.

The calculation of the number of series turns required to produce a desired compounding effect requires experience and judgment. For practical purposes it is best to determine by experiment the loss in e. m. f. caused by full load on the machine when operated as a shunt generator, and then to wind upon the field a few turns of wire through which may be sent a current from a storage battery or other source of continuous current. The current in these extra turns is adjusted to give the desired compounding. Having experimentally determined the proper number of series ampere-turns to overcome the resistance of the armature and series field windings and the armature reaction, it is necessary to decide upon the allowable resistance and consequent size of the series and shunt wire. As in the previous cases, the radiating ability of the coils determines the allowable losses, which are now produced in both the series and shunt coils.

CHAPTER VI.

CONSTRUCTION OF ELECTRIC GENERATORS.

OUTLINE.

Elements of Electric Generators:

The Alternator.

The Armature.

The core — the coils — armature windings — connection to circuit — ventilation.

The Field Magnet.

The core — ventilation — the coils — excitation.

The Direct Current Generator.

Commutation.

The Armature.

The core — the coils — the commutator.

Elements of Electric Generators.

AN electric generator is a device for the transformation of other forms of energy into electrical energy. This definition is very comprehensive and includes primary batteries and thermo-electric couples. For practical purposes the transformation from mechanical to electrical power is the principal one and will alone be considered in this chapter. The name *dynamo-electric machine* was at one time used to designate an electric generator and this was shortened to the meaningless term "*dynamo.*" Fortunately this word is passing out of use and the self-defining terms *d. c. generator*, *a. c. generator* or *alternator*, *motor-generator set*, etc., are preferred.

The general underlying principle of all generators is that of the Faraday disk generator; namely, that a conductor cutting a magnetic field generates an e. m. f. the direction of which depends upon the direction of motion and upon the direction of the field. Further, the e. m. f. is proportional to the flux density, to the velocity of the conductor, and to the length of the conductor.

The different forms taken by electric generators are the result of the application of the general principle to particular requirements. For example, the apparatus developed early in the last century was designed for current supply from primary batteries, this being the only available source of electric power at that time. The early generators were, therefore, constructed to supply the same kind of current. As the electric generator is inherently an alternator, complicated rectifying devices had to be designed to enable it to yield direct current. The result was the development of successful d. c. generators. As the d. c. generator became more and more perfect, apparatus to utilize the output was also perfected, and thus the commercial position of d. c. systems was firmly established. Between 1880 and 1890 apparatus was devised for utilizing the alternating current, including transformers, motors, lamps, and auxiliaries, and since that time the a. c. generator has developed rapidly. At present both d. c. and a. c. generators are in common use and the design and construction of both types are well standardized. Except for minor differences the machines produced by various manufacturers are similar in appearance and performance, and they are as simple as possible in construction. The tendency is toward simplicity and away from the complicated mechanisms considered necessary at one time to overcome the faults of design and construction.

The essential elements of all generators are:

1. A magnetic circuit for maintaining magnetic flux through which electric conductors can be moved conveniently, with a source of magnetomotive force for the same. This "field magnet" may be stationary or it may revolve.

2. A set of electrical conductors suitably connected and mounted on a support, preferably part of the magnetic circuit. Provision must be made for maintaining relative motion of the "armature" conductors and the magnetic flux.

3. Auxiliary devices for conveying current from or into the rotating part of the machine.

The armature of the continuous current machine invariably revolves, current being conducted from the winding through a "commutator" as in all constant potential and in a few constant current generators, or through a "rectifier" as in most constant current machines. In the "alternator," either armature or field may revolve and the current is conducted through "collecting rings" to or from the moving member in either case. "Fly-wheel-effect" often makes motion of the field magnet desirable.

The source and nature of the magnetomotive force for the magnetic circuit of a generator determines to some extent the nature of the armature output. The possible sources of m. m. f. as detailed in Chapter V are:

1. *Separate Excitation* from an auxiliary circuit as used in most alternators except such as are mentioned under class (4). The continuous current generator supplying the field current is known as the "exciter."

2. *Shunt Excitation*, that is by connection of the field circuit across the armature terminals. This plan is used in many constant potential, continuous current lighting generators.

3. *Series Excitation*, the line current passing through the field circuit. It is used on constant continuous current generators only.

4. *Compound Excitation*, a combination of series and shunt or of series and separate excitation. Compound excitation is used either in continuous or alternating current generators where either a perfectly uniform pressure is desired or where the pressure should rise with increase of load. The latter frequently receives the name "over-compounding."

In compounding alternators all or part of the line current is rectified and passed through the series field coils, such an arrangement being usually designated "composite wound." A compounding effect is also produced very successfully without the aid of a series winding by sending the alternating current through the armature of the exciter, modifying its field flux and e. m. f. and in turn the field current of the alternator. This combination of exciter and alternator is called a "compensated" alternator, and the method provides for variable power factor as well as variable load. Alternators are, in general, not compounded, as they can be designed for satisfactory inherent regulation through the experience gained by manufacturers during the past twenty years in which alternators have been in general use.

All generators comprise three essential features whether for alternating or direct current. These are:

1. *The Armature*, consisting of the support for the laminated structure, the magnetic circuit, the winding, the devices for connecting to the line circuit, such as commutators, brush-holders, etc.

2. *The Field Magnet*, including mounting for the magnetic circuit, the field cores, the winding, the circuit connections.

3. *The Mechanical Mounting* of armature and field magnet as a whole.

The Alternator.

The Armature. The armature of the alternator, as of other generators, is the part in which e. m. f. is generated. In the alternator it may either revolve or be stationary, and the names *revolving field* alternator, and *revolving armature* alter-

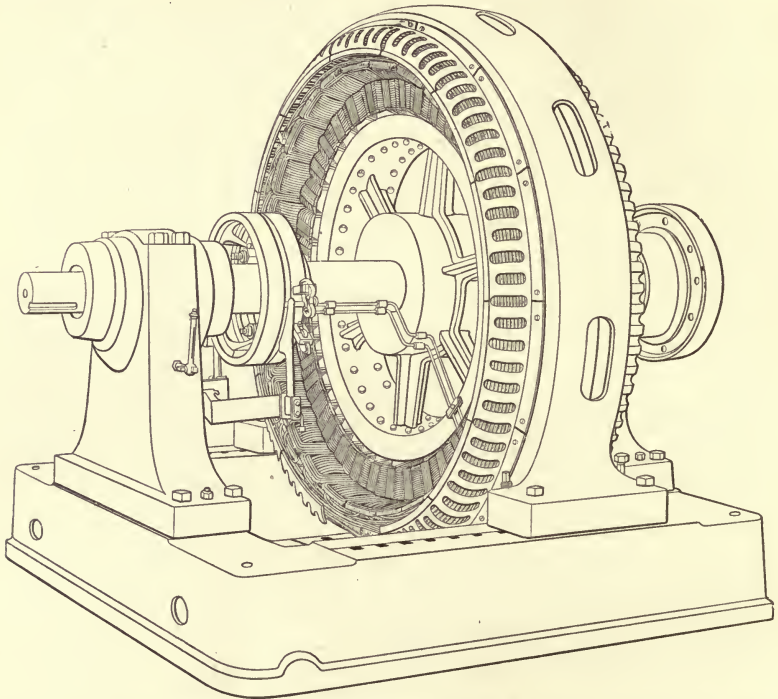

FIG. 58. View of 200 k. w. revolving field alternator. (Westinghouse.)

nator indicate the types from this standpoint. The essential fact is that the flux of the field must cut or be cut by the conductors, and which shall be done in a particular case is largely a matter of convenience of construction and of mechanical design.

The core of the armature serves to support the winding and to act as part of the magnetic circuit. It is usually in the

form of a ring a few inches in radial depth and is built up of thin stampings of electrical steel. These are insulated from each other by varnish, and they are held together by bolts and clamps so as to insure a substantial structure. This *laminated* ring is carried upon the outside of a cast iron or steel wheel in revolving armature machines and upon the

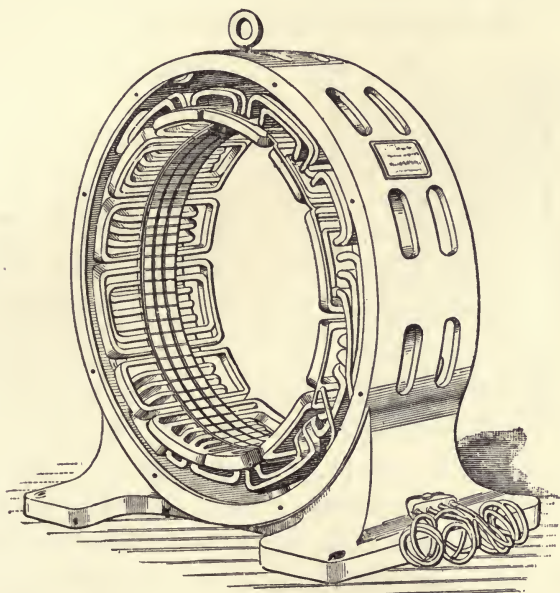

FIG. 59. Alternator armature (Westinghouse) for revolving field type, showing details of coils, core and frame 200 k. w.

inside of a cast iron frame when it is to remain stationary. The purpose of laminating and insulating the stampings of the armature core is to prevent the circulation of local or *eddy* currents in it. The iron of the core cuts the flux just as do the copper conductors, and as iron is a conductor, also, e. m. f. is generated in it and current tends to circulate in the same directions as those taken by the useful currents.

By laminating and insulating the core in planes normal to the axis this tendency is to a large extent reduced and the heating due to eddy currents is rendered almost negligible. Hysteresis loss in the armature core is kept down by employing the best grades of electrical steel, and the lamination and insulation of the sheets has no effect upon this loss except that in the sheet form it is easy to secure good material and to anneal it for the purpose of reducing the hysteresis coefficient.

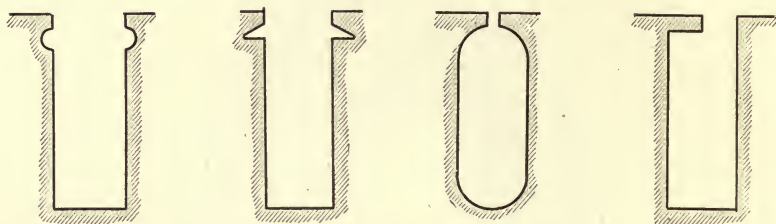

FIG. 60. Diagrams of a number of slot forms used in alternator armature cores.

The surface of the core in contact with the air gap is slotted for the reception of the coils. The slots used are of various forms, as shown in Fig. 60, from the open slot with straight sides and open top, to one almost entirely "closed-over." The slot construction gives excellent mechanical support to the conductors and permits of the use of substantial insulation upon the coils. The open slot allows the use of a coil completely formed and insulated before being put in its place upon the core. It has also the advantage of giving a poor magnetic circuit around the coil, and hence the coil has a small inductance. It does not give as good mechanical support for the coils as the partly closed-over slots, for the coils must be secured by wedges driven into grooves near the tops of the slots. The partly closed-over slots require a more expensive and tedious method of inserting the coils, which must either be put into place, one conductor at a time, or a

complete coil must be cut at one end and rejoined after being placed in position.

The coils are formed of cotton-covered wire, round or square, and molded to the proper shape upon wooden or metal forms. These forms are usually revolved upon a lathe head in order to reduce the cost of manufacture and to secure uniformity of product. The form of the coils is largely a matter of geometry and convenience of mechanical construction.

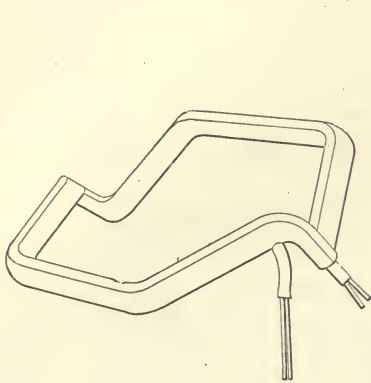

FIG. 61. Machine-formed coil for alternator armature, bent to permit overlapping.

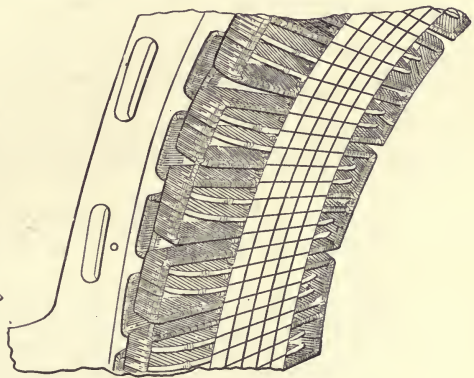

FIG. 62. Part of alternator armature showing second method of winding.

Common forms of coils are shown in Figs. 61 and 62. With the type shown in Fig. 61 but one size and shape is required for an armature, with the other there are usually several sizes and shapes required. The type shown in Fig. 62 is the most generally used in alternators.

The insulation of the coils is of prime importance, as upon this largely depends the successful operation of the machine. It is one of the most difficult features of design and construction. Varnished cloth and paper, oiled cloth and paper, mica, fuller-board and mineral wax compounds, enter into the construction of armature coils. In addition to the cotton upon

the individual conductors, the layers are separated by fuller-board, and the coil as a whole is wrapped with layers of the various fabrics indicated. The cotton is impregnated with varnish or mineral wax to insure dielectric strength and to repel moisture. In many cases the slot is lined with troughs made of fuller-board or micanite (mica sheets cemented together with shellac or varnish). By means of the modern methods of insulating armature coils it is possible to construct alternators to give 15,000 volts e. m. f., but at this pressure the insulation occupies the larger portion of the slot space and the armature is consequently bulky for its output.

Armature windings for alternators are of many different forms, but the same general principle is involved in all, namely,

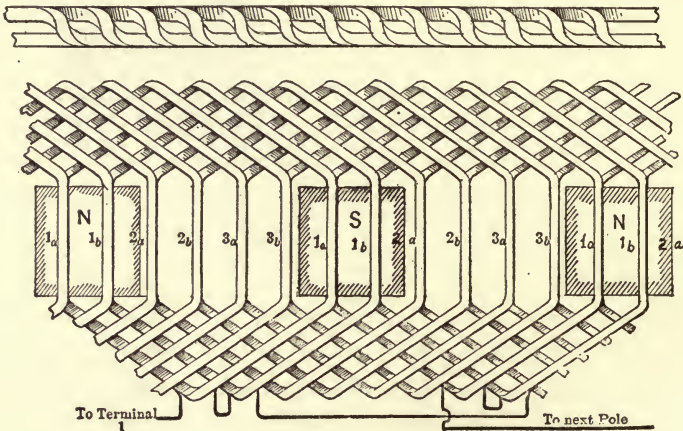

FIG. 63. Diagram of three-phase winding using but one form of coil. (That shown in Fig. 60.)

to connect the conductors of each phase or section of the winding in series by as symmetrical arrangement as possible. This is indicated by Figs. 63, 64, 61, 62 and 59. In a single-phase alternator all of the conductors are commonly connected

in series with two terminals which go to the outside circuit. In a single-phase winding it is not necessary to entirely cover the armature surface with slots and coils, as this involves some waste of copper through the neutralization of e. m. f. in different parts of the same coil which would cut the same field in opposite directions at the same time. Polyphase windings are produced by dividing the polar space upon the core into as many sections as there are phases and each space is entirely filled with an independent winding.

Fig. 63 shows a three-phase winding made of coils like those of Fig. 61. Fig. 64 represents a two-phase winding of

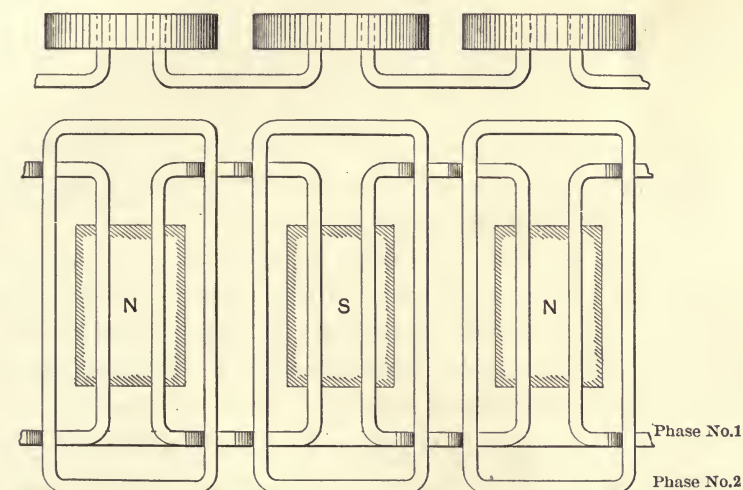

FIG. 64. Diagram of two-phase winding using several forms of coil.

coils of the general form shown in Fig. 62. Either three-phase or two-phase windings may be formed with either type of coil.

Two-phase windings as a rule consist of two separate circuits with two pairs of terminals connected with the outside circuit, each winding occupying one-half of the armature surface. It is possible and sometimes desirable to connect the

entire winding in series, closing the ends, and to tap into it at such points as will give the desired phase difference for the two-phase circuits as in Fig. 65. This winding is equally

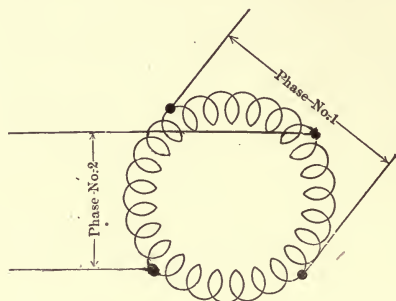

FIG. 65. Diagram of interconnected or closed-coil two-phase winding. Any closed winding may be thus connected.

good for two-phase or four-phase current. It has the disadvantage that the two windings are interconnected and any trouble in one affects the other.

Three-phase windings, as indicated above, consist of three sections, in each of which an e. m. f. is generated, the three e. m. f.'s. being 120 degrees apart in phase position. For connection to the outside circuit the three windings may be connected in either of two ways.

(a). One end of each coil may be joined to a common or neutral point and the other end may go to the outside circuit. This is the *Y* connection and an armature thus arranged is said to be *Y-connected* or *star-connected*. In this style of connection the e. m. f. between line conductors is the geometrical sum of the e. m. f.'s of the two windings, and as the e. m. f.'s are 120 degrees apart it is $\sqrt{3}$ times that in either winding. The current in the armature windings is the same as in the line wires to which they are connected. Fig. 66 shows the *Y*-connected winding.

(b). The three sections may be connected in series, forming a closed winding, the junctions between windings going to the line. This is the Δ -connection and such an armature is called Δ -connected or mesh-connected. In this case the e. m. f. between the line conductors is the same as that in each section

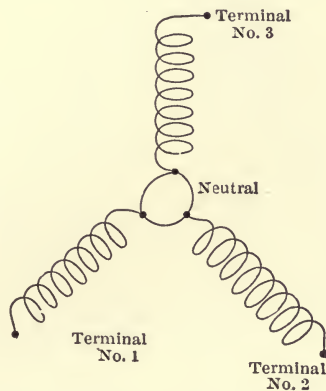

FIG. 66. Diagram of "Y" or star-connection of the three armature windings of a three-phase armature.

of the winding. The current in each line wire is the geometrical sum of the currents in adjacent windings, hence, if the currents drawn by all lines are equal, each winding will contain the geometrical difference of two currents 120 degrees apart.

Each will therefore be $\frac{1}{\sqrt{3}}$ times the line current. Fig. 67 shows the Δ -connection.

Connection to circuit. If the armature is stationary the connections to the line are made through insulating bushings and terminals at one side of the armature frame. The current from revolving armatures is taken off through brass or steel collector rings carried by the shaft and well insulated therefrom, the conductors being brought out along the surface of the shaft and secured firmly in place. Stationary copper or

'carbon "brushes" bear upon the rings and serve to connect them through the sliding contact with the line. The brush

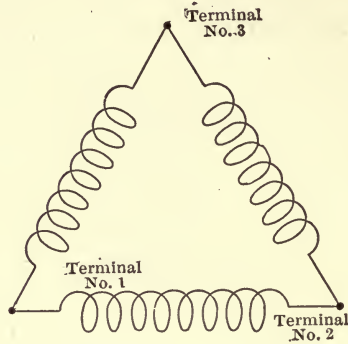

FIG. 67. Diagram of "Δ" or mesh connection of the three armature windings of a three-phase armature.

holders are carried upon brackets usually mounted upon the bed plate.

Ventilation of the armature is secured by allowing currents of air to flow radially through the core and windings. The core is made in sections with flues between, and the winding is made open so as to interfere as little as possible with the flow of air. The ends of the coils are carried well beyond the ends of the core and are spread out to increase their heat radiating ability. In very compact, high-speed alternators such as those directly connected to steam turbines, it is usually necessary to place fans upon the revolving part (usually the field magnet) to secure a rapid circulation of air.

The Field Magnet. The field magnet of the alternator has for its function the maintenance of a magnetic flux between the pole surfaces and the armature core. The form taken by the core of the magnet depends largely upon the conditions under which it is to operate. A revolving magnet is of radically

different mechanical construction from a stationary one, although the magnetic and electrical features are the same. The number of poles in the magnet is determined solely by the frequency desired and the speed. A conductor upon the

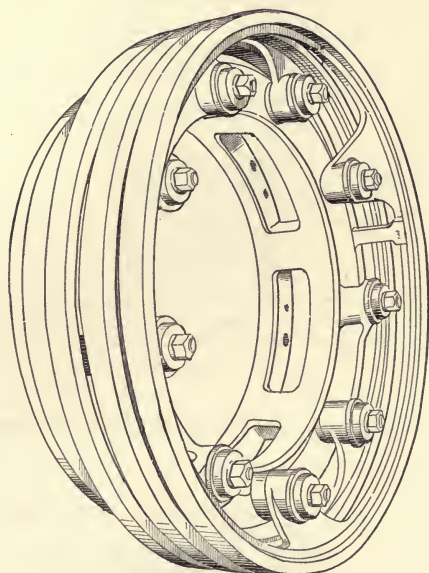

FIG. 68. View of "spider" collector rings for the armature of a revolving armature alternator (Westinghouse).

armature generates a cycle of e. m. f. in passing a pair of poles. Hence the frequency is the number of pairs of poles passed per second by a point on the armature. For example, a ten-pole armature rotating at 720 r. p. m. generates e. m. f. at 60 cycles per second. The result of this necessity for producing a given frequency is that alternators have many poles and these poles are small in machines of moderate output.

The core of a revolving field alternator magnet may be of cast steel or sheet steel, cast iron being out of the question on

account of its bulk and its mechanical weakness. Not only is the bulk of cast iron directly objectionable, but the large

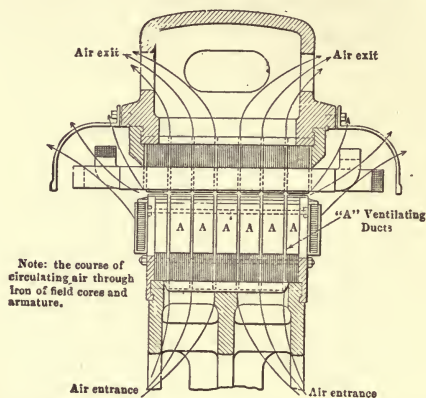

FIG. 69. Diagram showing ventilating system of a revolving field alternator (Westinghouse).

perimeter of a pole core necessary to contain a given magnetic flux requires a greater amount of copper in the coil for a

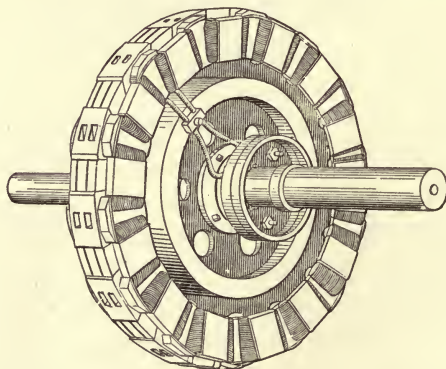

FIG. 70. View of revolving field of 200 k. w. alternator (Westinghouse).
(See Figs. 58 and 59 for general view and armature.)

given number of ampere-turns. The mean length of a turn is greater and as the allowable heating is limited, the cross-section

of the copper conductors must be larger to keep down the resistance. When cast-steel poles are used they are bolted to the rim of a strong fly-wheel structure of cast steel or iron. The rim forms part of the magnetic circuits. Sheet-steel poles are punched in sections as shown in Fig. 71 and the

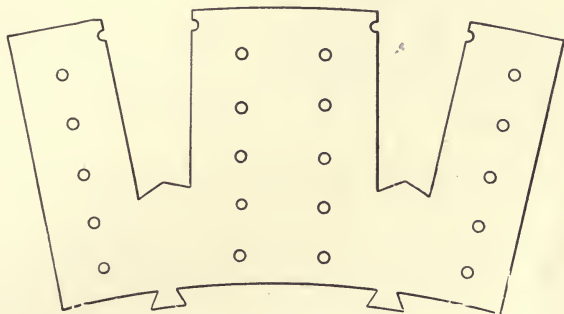

FIG. 71. Field core stamping of electrical steel for revolving field alternator (Westinghouse) showing bolt holes for assembling and securing sheets.

sections are overlapped and bolted together. The assembled field core is supported upon a cast fly-wheel structure by dove-tail groove and tenon or other mechanical device for insuring rigidity. Sheet-steel poles have the advantage of obviating the formation of eddy currents through the fluctuation in the flux. Such fluctuation is always present with slotted armatures which tend to localize the flux in "bunches." As the bunches of flux "snap" from slot to slot they cut the pole iron and tend to generate local currents therein.

As revolving field alternators are usually of the engine-type (directly mounted upon the engine shaft) the field structure supplements or takes the place of the fly-wheel, hence the weight is not objectionable.

The stationary field magnet of a revolving armature machine is simpler in construction than a revolving magnet. The pole

cores are either of sheet steel or cast steel. If of the former, the stampings are provided with a dove-tail tenon and after assembling are cast into the iron frame. The latter in all large machines is made in two sections so that the upper part may be lifted off to expose the armature for inspection and repair.

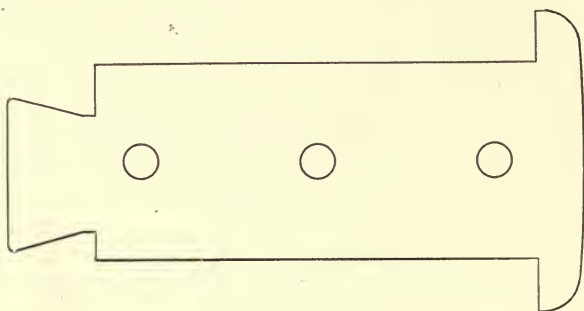

FIG. 72. Field core stamping of electrical steel for revolving armature alternator (Allis-Chalmers Co.) showing dove-tail tenon to be cast into frame.

The ventilation of the revolving field is provided by air ducts in the laminated structure corresponding to those in the armature core. It is not practicable to use such flues with stationary field machines.

The coils of the field magnet are wound either with cotton-covered square or round wire or bare copper strap bent edge-wise as shown in Fig. 73. The last named is afterward insulated by sheet insulation inserted between turns. The strap winding possesses mechanical stability and is used on most large machines particularly of the rotating field type. As an exciter e. m. f. of not over 135 volts is used the insulation of the field coils presents no difficulty. Wire-wound coils are impregnated with insulating varnish and securely taped, but the outer surfaces of strap wound coils are left unprotected

in order that the exposed edges of the copper strap may directly radiate the heat generated in it.

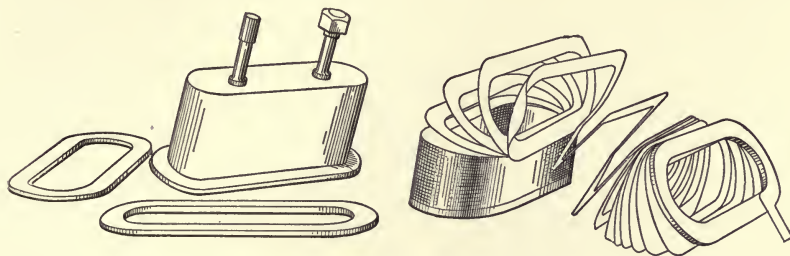

FIG. 73. Alternator pole core with strap edgewise wound coil (G. E. Co.),

The field coils are held in position by wedges or by bolts and clamp plates and the fastening must be such that there will be no chafing of the coil insulation. In many machines brass or copper plates or grids are wedged into grooves punched near the outer ends of the pole pieces. These serve to hold the field coils in position. The most important function of these "dampers" is to increase the steadiness of rotation of the revolving part, for when two or more alternators are operating in parallel, that is, supplying current to the same circuit, there is a tendency for them to interchange current if they do not all revolve at perfectly uniform angular velocity. By the generation of eddy currents in the dampers and by their action upon the field, steadiness of running is increased. Dampers are absolutely necessary with sheet-steel poles. When solid poles are used the steadying currents circulate in the pole pieces and render the use of dampers less important.

The *excitation* of alternators is provided usually by an auxiliary d. c. generator with a capacity of from two to five per cent of that of the alternator and with a range of from 80 to 125 volts e. m. f. One exciter may supply several alter-

nators with field current in a power station. A revolving field winding receives its exciting current through collector rings of

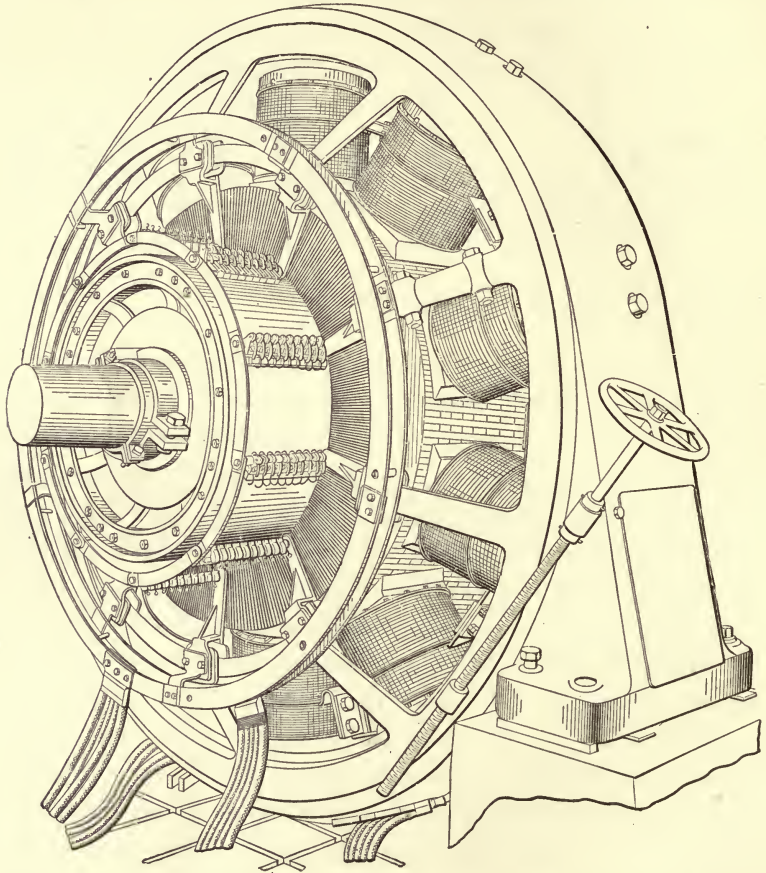

FIG. 74. General view of large compound wound d. c. generator (G. E. Co.). iron or brass similar in general form to those shown in Fig. 68 but only two in number.

The Direct Current Generator.

The only radical difference between the direct current generator and the revolving armature alternator is the *commutator*,

the device which permits the machine to furnish continuous current in spite of the fact that it generates an alternating e. m. f. in its windings. The principle underlying the rectifying action of the commutator is shown in Figs. 75 and 76. Fig. 75 represents a bipolar field with an armature consisting of a ring core wound continuously with coils of wire forming a complete closed circuit. As the armature revolves it generates e. m. f. under each pole, but these polar e.m.f.'s oppose each other in the armature circuit, hence no current flows. Con-

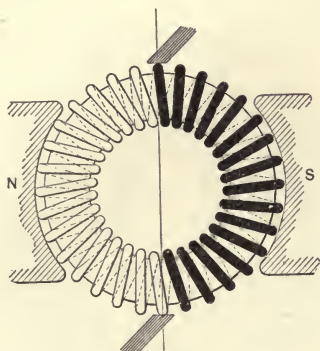

FIG. 75. Diagram illustrating principle of commutation, brushes bearing directly upon winding.

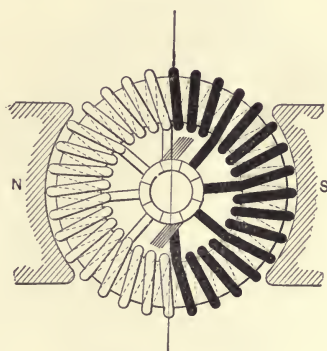

FIG. 76. Diagram illustrating the purpose of the commutator in d. c. generators.

sider that the outer surface of the conductors is bare so that fixed contact brushes may rub upon them. Continuous current may be taken from these brushes if they are placed between the poles, for the e. m. f.'s generated under the poles are stationary in direction with respect to the poles although alternating with respect to the conductors. Obviously it is impracticable to allow the brushes to bear upon the conductors as it would be very difficult to insulate them.* Instead, a

* A number of generators of considerable size were constructed exactly along these lines and they were a few years ago on the market.

cylinder of copper split into a number of segments, which are insulated from each other, takes the wear which would otherwise come upon the conductors. These commutator segments are tapped into the windings at equidistant points as shown in Fig. 76 and the commutator is mounted upon the armature shaft near one end of the core.

The Armature of the d. c. generator for mechanical reasons invariably revolves. The current is taken from the armature through a commutator and brushes, and if the armature

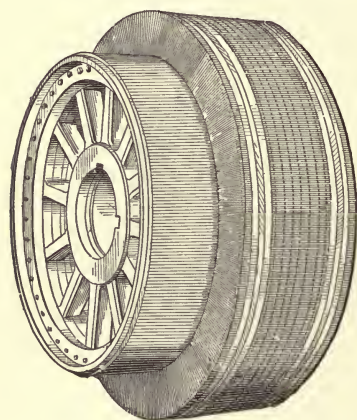

FIG. 77. View of large d. c. armature from commutator end (G. E.).

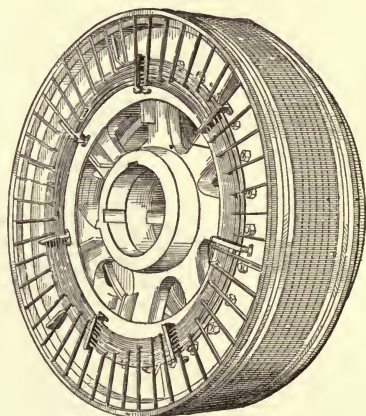

FIG. 78. View of large d. c. engine armature from end showing bonding rings for equalizing potential in different parts of winding (G. E. Co.).

remained stationary the brushes would have to revolve with the field magnet. The mechanical impracticability of this has been demonstrated by unsuccessful experiments. Further, the brushes need adjustment to prevent sparking and this can only be done satisfactorily while the machine is in operation. It would be almost impossible to adjust the brushes if they were revolving at high speed.

The core of the armature is essentially the same as that of a revolving armature alternator. The radial depth of core is usually greater than in an alternator of the same capacity, as the d. c. machine has fewer and larger poles, hence the flux per pole is greater. In general, also, the slots are smaller in size and greater in number, as it is necessary to keep down the number of turns in a coil in order to allow of successful commutation. It is difficult to reverse the current in a coil which has a large number of turns and a consequently large inductance.

The coils are of the form shown in Fig. 61 and in section in Fig. 79. They are all connected in series with the ends

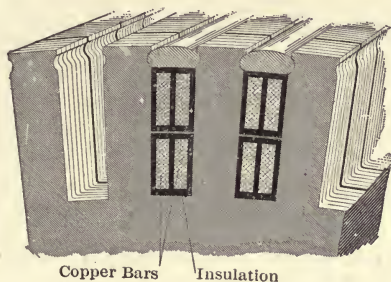

FIG. 79. Cross-section of d. c. armature tooth, conductors and insulation (Allis-Chalmers Co.).

closed, forming the *closed winding*. In connecting the coils in series two methods are used, producing:

- (a) The series or wave winding.
- (b) The lap or parallel winding.

The *series winding* is similar to that shown for the three-phase alternator in Fig. 63, except that all of the conductors are connected in one circuit, the ends of which are closed. The name "series" is given to this winding because all of the conductors are connected as nearly in series as possible. Reference to Fig. 75 will show that in a closed winding there

can never be less than two paths through the winding between any two points. The series winding is, therefore, one in which there are two paths or circuits between brushes regardless of the number of poles. The manner in which this is accomplished is shown in Fig. 80.

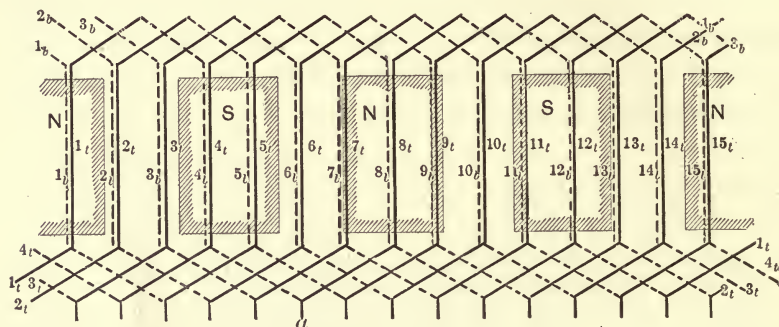

FIG. 80. Diagram of wave winding for d. c. armature as used in railway and other motors and some generators.

The diagram represents the winding cut between slots 1 and 15 and laid out flat or "developed." If the diagram were cut out and pasted to form a ring it would represent exactly the appearance of the coils in place. Coils like those shown in Fig. 61 are placed with one side in the bottom of one slot and the other in the top of the third slot away. The solid lines indicate that the corresponding coil side is in the top of a slot, the dotted lines that it is in the bottom of a slot. Dotted end connections are in the lower plane or slot-bottom plane, solid end connections are in the upper plane or slot-top plane. The coils may be designated 1_4 , 2_5 , etc. As many turns as are needed to produce the desired e. m. f. may be wound in each coil before it is connected in series with the next one. As a rule this number is very small. The connections of the coils may be followed by taking a starting point a and tracing the path of the current in either direction.

Assume that at a particular instant commutator lead a is connected to the commutator bar under a brush. The series from left to right is then as follows:

Coil $8,11_b$ to coil $15,3_b$ to coil $7,10_b$ to coil $14,2_b$ to coil $6,9_b$ to coil $13,1_b$ to coil $5,8_b$ to coil $12,15_b$ to coil $4,7_b$ to coil $11,14_b$ to coil $3,6_b$ to coil $10,13_b$ to coil $2,5_b$ to coil $9,12_b$ to coil $1,4_b$ to coil $8,11_b$ which is the starting point and which therefore closes the winding after all slot space has been filled. Each junction between coils is connected to a commutator bar as shown in Figs. 80 and 76. The e. m. f. produced by such a winding is one-half the sum of the average e. m. f.'s. of all the conductors. The wave winding produces, therefore, the greatest e. m. f. possible from a given number of conductors. It is useful where a high e. m. f. is desired and where the current output of the machine is not excessive. It cannot be used in very large generators because the conductors would be too massive for convenient mechanical construction.

The choice of the number of slots and pitch of coils (distance between sides measured in slots) is largely a geometrical matter. As the two sides of a coil are in series, one must be under a north pole when the other is under a south pole or their e. m. f.'s. will neutralize. The coils must therefore be approximately as wide as the distance between pole centers. The number of slots cannot be a multiple of the number of poles, however, or the winding would close upon itself before the slots were filled. Hence the total number of slots is one more or less than a multiple of the number of poles. In the case taken, a four-pole machine, the number of slots is 15 or one less than four times four. Seventeen would have been just as satisfactory, as would 19, etc. This principle is very much like the "hunting tooth" used with spur gears to prevent uneven wear. That is if the number of teeth

upon the gear (or larger wheel is an even multiple of the number upon the pinion the same teeth will always be in contact and unevenness of wear will result. If a tooth be added to or subtracted from the number upon the gear, the teeth will be continually changing places with respect to each other.

The *lap winding* is made from the same coils as the series winding, but instead of the connections progressing in a "wave" around and around the core, adjacent coils are connected in series, as indicated in Fig. 81. The same number of slots and poles and the same width of coils, in fact the

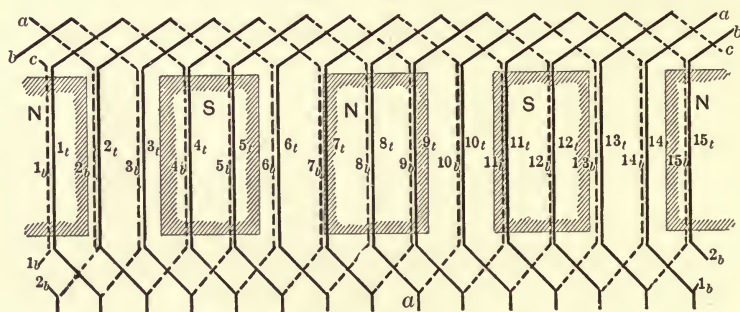

FIG. 81. Diagram of lap winding for d. c. armatures as used in large d. c. generators, rotary converters and some motors.

same coils are used in this case. Starting at the same coil as before, $8_t 11_b$, from the point *a* the coils are connected in the following order:

Coil $8_t 11_b$ to coil $9_t 12_b$ to coil $10_t 13_b$, etc., progressing forward one slot each time. In this winding there are as many paths as poles, for the e. m. f.'s. generated under successive poles are in opposite directions. The effect is similar to a series of four cells of battery connected as in Fig. 82. Each cell represents the e. m. f. generated under one pole of the field. They are connected + to +, - to -, + to + and - to -. No current can flow around the battery circuit

and to utilize the current in an outside circuit the two + and the two - points must be connected together. Similarly four brushes are needed for the four-pole winding shown and the two pairs of positive and negative brushes must be connected together. Only two brushes are needed for the series winding. The lap winding is used for all large generators. The total current is divided up among a number of armature circuits, so that the conductors may be small and easily

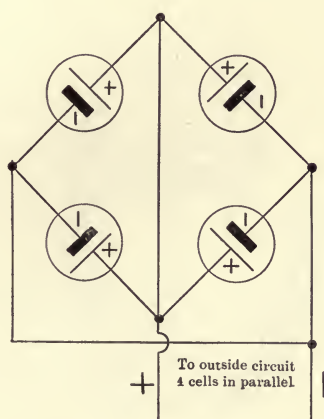

FIG. 82. Diagram showing four cells of battery connected like the sections of a lap wound d. c. armature.

handled. The choice of the number of slots in a lap winding is a simpler matter than in the preceding case. Practically any number of slots will be satisfactory.

There was originally a great deal of trouble with lap windings caused by the interchange of current among the various paths of the winding when the e. m. f's. were not equal in them. This is now prevented by bonding together a number of equi-potential points in the winding, the rings for this purpose being located at the end of the core opposite to the commutator.

The Commutator. The principle of the commutator has already been briefly described. Its mechanical construction is indicated in Fig. 83. The segments are of rolled or forged copper and they are separated by soft mica insulating sheets. This mica must wear down evenly with the copper hence its consistency is important. The segments are wedge-shaped so that when drawn radially inward they support each other like the stones of an arch. They are drawn together by hol-

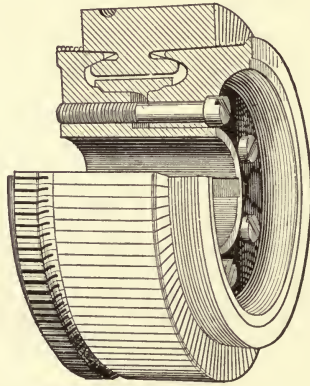

FIG. 83. View and section of a commutator (G. E. Co.), showing segments, collars, insulation, etc.

low cone collars which bear upon lugs projecting from the ends of the segments. These lugs are turned to form a smooth cone after the segments are assembled. The collars are insulated with mica from the segments and they are held in place by nuts upon the commutator shell or by bolts passing from end to end under the segments. The segments are also provided with lugs for connection to the windings. These "leads" from the coils which are to be connected in series are joined in the commutator lugs which thus perform two functions.

The "brushes" are small carbon blocks pressed against the commutator by springs and supported in brass frames or brush holders. The brushes are inclined to the radial direction, in some cases in the direction of rotation, in others, against it. The purpose of this inclination is to prevent vibration and consequent sparking. The brushes are partly copper-plated to permit the soldering of flexible cables or "pig-tails" to them. This mode of connection reduces the heating by improving the electrical connection between the brushes and the holders.

The brush holders are carried upon studs mounted in a ring which can be moved or rocked backward and forward to permit the adjustment of the brushes to the "sparkless" position upon the commutator. In large machines this "rocker arm or ring" is operated through gear and hand wheels.

The Field Magnet of the d. c. generator does not differ in essential principle from that of the revolving armature alternator. A noticeable feature is that the poles are usually larger than in an alternator of similar output. There is in this case no restriction as to frequency and the number and size of poles may be determined from considerations of manufacturing economy and convenience. The field magnets are always stationary and the pole pieces are usually built up of sheet-steel punchings bolted against or cast into a cast iron or steel frame. As in the case of the alternator the lamination of the pole pieces prevents the circulation of eddy currents. There is an additional advantage in this case. The operation of a d. c. generator is much better if that portion of the pole piece next the air gap is heavily saturated. With punched pole pieces part of the pole shoe can be cut away by a number of methods of which a good example is shown in Fig. 84. Alternate punchings are reversed in build-

ing up the core so that for a short distance into the pole the

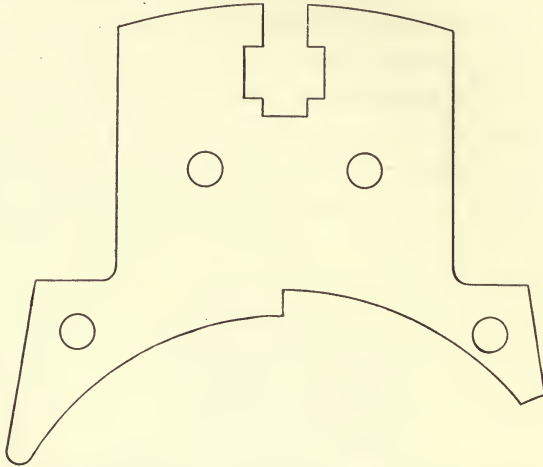

FIG. 84. Pole stamping for d. c. generator field core (Allis-Chalmers Co.) showing one-half pole face cut away to produce magnetic saturation.

net steel section is but one-half what it would be in an ordinary pole.

The field coils are similar to those of the alternator except

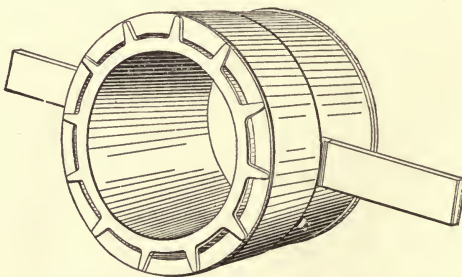

FIG. 85. Field coil for d. c. compound generator, showing shunt and series sections.

that they are usually in two sections: (a) *the shunt coil* of round or square wire, carrying a small exciting current; and



(b) *the series coil* of copper strap, carrying the line current. The coils are supported in such a manner as to allow excellent ventilation which is doubly important on account of the presence of two coils. The coils of each section are connected in series, the shunt coils being connected either across the brushes or across the terminals of the machine (short and long shunt, respectively) with a regulating resistance in series. One end of the series windings is connected to a brush, the other to the line.

CHAPTER VII.

OPERATION OF ELECTRIC GENERATORS.

OUTLINE.

Regulation:

Alternator Characteristics: Regulation — Efficiency — Iron loss — Saturation — Heating — Short-circuit.

Alternator Handling: Synchronizing — Distribution of load — Balancing of phases.

D. C. Generator Characteristics: General Principles — Field Compounding — Commercial Compounding — Saturation — Efficiency.

D. C. Generator Handling.

Regulation. Electric generators in general have for their purpose the transformation of mechanical into electrical power through the cutting of a magnetic field by conductors. Their output is produced under certain specifications as to e. m. f., frequency, allowable steady and momentary current, etc. For example an alternator may be expected to deliver at a certain speed, an e. m. f. which is within a specified percentage of a constant value when the load is varied in amount and character. This is known as its *regulation* or *inherent regulation*, the latter name indicating that the e. m. f. is regulated by the machine itself and not by any auxiliary devices. Occasionally a generator is required to produce a constant current in which case specifications call for a certain current regulation with variable resistance in the circuit. The operation of all machines may be determined by simple

tests and the results of these are always exhibited graphically in the form of *characteristic curves*.

It is necessary that engineers agree upon the terms to be used and the tests to be employed in rating electrical machines, and this is done through the Standardization Committee of the American Institute of Electrical Engineers.* The report of this committee, revised from time to time, forms the basis of agreement between manufacturer and purchaser. The paragraphs relating to the matter of regulation are as follows:

D. REGULATION.

(I) DEFINITIONS.

DEFINITION. The regulation of a machine or apparatus in regard to some characteristic quantity (such as terminal voltage, current or speed) is the ratio of the deviation of that quantity from its normal value at rated load to the normal rated load value. The term "regulation," therefore, has the same meaning as the term "inherent regulation," occasionally used.

CONSTANT STANDARD. If the characteristic quantity is intended to remain constant (*e.g.*, constant voltage, constant speed, etc.) between rated load and no load, the regulation is the ratio of the maximum variation from the rated-load value to the no-load value.

VARYING STANDARD. If the characteristic quantity is intended to vary in a definite manner between rated load and no load, the regulation is the ratio of the maximum variation from the specified condition to the normal rated-load value.

(a) **NOTE.** If the law of the variation (in voltage, current, speed, etc.) between rated-load and no-load is not specified, it should be assumed to be a simple linear relation; *i.e.*, one undergoing uniform variation between rated-load and no-load.

(b) **NOTE.** The regulation of an apparatus may, therefore, differ according to its qualification for use. Thus, the regulation of a compound-wound generator specified as a constant-potential generator, will be different from that which it possesses when specified as an over compounded generator.

In **CONSTANT-POTENTIAL MACHINES** the regulation is the ratio of the maximum difference of terminal voltage from the rated-load value (occurring within the range from rated-load to open-circuit) to the rated-load terminal voltage.

* The complete report of the committee may be obtained at a nominal price from the Am. Inst. of Elec. Engineers, 33 West 39th St., New York City.

In **CONSTANT-CURRENT MACHINES** the regulation is the ratio of the maximum difference of current from the rated-load value (occurring within the range from rated-load to short-circuit, or minimum limit of operation), to the rated-load current.

In **CONSTANT-POWER APPARATUS**, the regulation is the ratio of maximum difference of power from the rated-load value (occurring within the range of operation specified) to the rated power.

In **CONSTANT-SPEED DIRECT-CURRENT MOTORS** and **INDUCTION MOTORS** the regulation is the ratio of the maximum variation of speed from its rated-load value (occurring within the range from rated-load to no-load) to the rated load speed.

The regulation of an induction motor is, therefore, not identical with the slip of the motor, which is the ratio of the drop in speed from synchronism, to the synchronous speed.

In **CONSTANT-POTENTIAL TRANSFORMERS**, the regulation is the ratio of the rise of secondary terminal voltage from rated non-inductive load to no-load (at constant primary impressed terminal voltage) to the secondary terminal voltage at rated load.

In **OVER-COMPOUNDED MACHINES**, the regulation is the ratio of the maximum difference in voltage from a straight line connecting the no-load and rated-load values of terminal voltage as function of the load current, to the rated-load terminal voltage.

In **CONVERTERS, DYNAMOTORS, MOTOR-GENERATORS AND FREQUENCY CONVERTERS**, the regulation is the ratio of the maximum difference of terminal voltage at the output side from the rated-load voltage, to the rated-load voltage on the output side.

In **TRANSMISSION LINES, FEEDERS, ETC.**, the regulation is the ratio of the maximum voltage difference at the receiving end, between rated non-inductive load and no-load to the rated-load voltage at the receiving end (with constant voltage impressed upon the sending end).

In **STEAM ENGINES**, the regulation is the ratio of the maximum variation of speed in passing slowly from rated-load to no-load (with constant steam pressure at the throttle) to the rated-load speed. For variation and pulsation see Secs. 59-64.

In a **HYDRAULIC TURBINE OR OTHER WATER-MOTOR**, the regulation is the ratio of the maximum variation of speed in passing slowly from rated-load to no-load (at constant head of water; i.e., at constant difference of level between tail race and head race), to the rated-load speed. For variation and pulsation see Sec. 59-64.

In a **GENERATOR-UNIT**, consisting of a generator united with a prime mover, the regulation should be determined at constant conditions of the prime mover; i.e., constant steam pressure, head, etc. It includes the inherent speed variations of the prime-mover. For this reason the regulation of a generator-unit is to be distinguished from the regulation of either the prime-mover, or of the generator contained in it, when taken separately.

(II) *CONDITIONS FOR AND TESTS OF REGULATION.*

SPEED. The REGULATION OF GENERATORS is to be determined at constant speed and of alternating apparatus at constant impressed frequency.

NON-INDUCTIVE LOAD. In apparatus generating, transforming or transmitting alternating currents, regulation should be understood to refer to non-inductive load, that is, to a load in which the current is in phase with the e. m. f. at the output side of the apparatus, except where expressly specified otherwise.

WAVE FORM. In alternating apparatus receiving electric power, regulation should refer to a sine wave of e. m. f., except where expressly specified otherwise.

EXCITATION. In commutating, rectifying machines, and synchronous machines, such as direct-current generators and motors, alternating-current and polyphase generators, the regulation is to be determined under the following conditions:

- (1) At constant excitation in separately excited fields.
- (2) With constant resistance in shunt-field circuits, and
- (3) With constant resistance shunting series-field circuits; i.e., the field adjustment should remain constant, and should be so chosen as to give the required full-load voltage at full-load current.

IMPEDANCE RATIO. In alternating-current apparatus, in addition to the non-inductive regulation, the impedance ratio of the apparatus should be specified; i.e., the ratio of the voltage consumed by the total internal impedance of the apparatus at full-load current, to its rated full-load voltage. As far as possible, a sinusoidal current should be used.

COMPUTATION OF REGULATION. When in synchronous machines the regulation is computed from the terminal voltage and impedance voltage, the exciting ampere-turns corresponding to terminal voltage plus armature-resistance-drop, and the ampere-turns at short-circuit corresponding to the armature-impedance-drop, should be combined vectorially to obtain the resultant ampere-turns, and the corresponding internal e. m. f. should be taken from the saturation curve.

Alternator Characteristics.

Regulation. Alternators are designed to produce as nearly constant an e. m. f. as possible, considering the requirements of the load to be operated. If incandescent lamps are to be the principal load the regulation must be close, but fortunately incandescent lamps, being almost entirely resistance, form a satisfactory load. On the other hand, loads which have

a comparatively low power factor (say 80 per cent) such as arc light circuits and induction motors, seriously interfere with the regulation of the alternator. A lagging current weakens the field of the alternator and hence less e. m. f. is produced than with the same output of higher power factor. All loads cause a falling off of e. m. f. on account of armature resistance.

The following table* gives the result of tests upon an alternator similar to that illustrated in Chapter VI.

200 K.W.—REVOLVING FIELD, BELTED TYPE GENERATOR—
3-PHASE—2200 VOLTS—7200 ALTS. 12-POLE—600 R.P.M.

PART I. REGULATION. Per cent rise in voltage when load circuit is opened.

Load.	POWER FACTOR.			
	100 Per cent.	95 Per cent.	90 Per cent.	80 Per cent
$1\frac{1}{4}$	10.4	16.3	18.1	20.9
1.	8.0	13.6	15.9	18.1
$\frac{3}{4}$	5.6	10.4	12.2	14.0
$\frac{1}{2}$	3.6	7.5	8.1	10.0

PART II. EFFICIENCY.

Load.	POWER FACTOR.			
	100 Per cent.	95 Per cent.	90 Per cent.	80 Per cent.
$1\frac{1}{4}$	93.85	93.33	92.67	91.52
1	93.30	92.60	92.04	90.82
$\frac{3}{4}$	92.00	91.25	90.62	89.30
$\frac{1}{2}$	89.06	88.13	87.38	85.59

The first part of this table contains data obtained by maintaining the speed and terminal e. m. f. of the machine constant while the load is varied in amount and power factor. For this purpose the load may be made up of variable resist-

* The tables and curves of alternator performance are used by courtesy of the W. E. and M. Co.

ance and reactance coils. The field current is adjusted in each case until the terminal e. m. f. is normal. The load is then thrown off, and after the speed has been adjusted the terminal e. m. f. is again measured. The percentage rise over

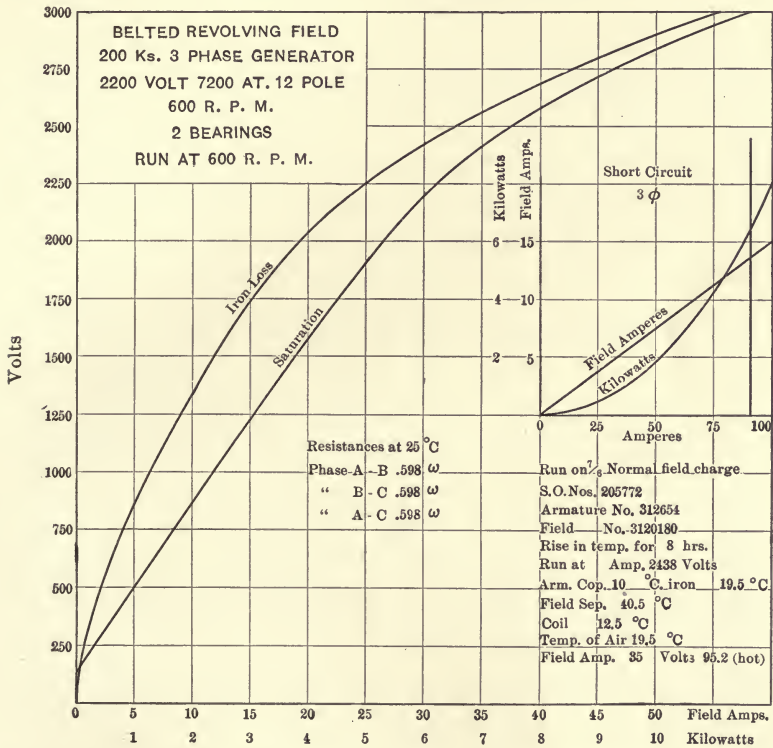

FIG. 86. Characteristic curves of 200 k. w., three-phase alternator (Westinghouse).

its value under load is its regulation for that case. The table covers tests for several power factors and loads. The rise ranges from a minimum of 3.6 per cent, when a half-load of unity power factor is thrown off, to 20.9 per cent with one and one-quarter load at 80 per cent power factor.

Efficiency. The second part of the table shows the efficiency in each test in Part I. The maximum efficiency is obtained with the largest load and highest power factor and vice versa. This is not always the case as many generators are designed to give their maximum efficiency at full load or even less.

Iron Loss. Fig. 86 shows other important characteristics of this generator. The *iron loss curve* is plotted between terminal e. m. f. on open circuit and k. w. absorbed in the iron. This loss has an important bearing upon the performance, for like the friction, it is always present when the machine is in operation. The iron loss is made up of eddy and hysteresis losses, the latter being the larger of the two.

The saturation curve, plotted between field current and terminal e. m. f. indicates the condition of the magnetic circuit, as the terminal e. m. f. is directly proportional to the flux. This curve differs in form from the magnetization curves of samples of iron because the circuit is made up of air and several kinds of iron. The dimensions of the circuit are different at the several parts and all do not saturate at the same time. The saturation curves for different machines are not necessarily of the same form.

Heating. In Fig. 86 are given, in tabular form, the results of heat runs on this alternator. As the output capacity of any electrical machine is determined by the allowable rise in temperature, such tests are the most important. The allowable rise is fixed by the maximum temperature at which the insulation and the iron may be safely operated. Under excessive heating the former is liable to soften and to carbonize, the latter to deteriorate magnetically by increase of the hysteresis coefficient (ageing). The Standardization Code deals fully with this matter in the following paragraphs.

LIMITING TEMPERATURE RISE.

GENERAL. The temperature of electrical machinery under regular service conditions, should never be allowed to remain at a point at which permanent deterioration of its insulating material takes place.

LIMITS RECOMMENDED. It is recommended that the following maximum values of temperature elevation, referred to a standard room temperature of 25 degrees Centigrade, at rated load under normal conditions of ventilation or cooling, should not be exceeded.

(A) **MACHINES IN GENERAL.**

In commutating machines, rectifying machines, pulsating-current generators, synchronous machines, synchronous-commutating machines and unipolar machines, the temperature rise in the parts specified should not exceed the following:

Field and armature, 50° C.

Commutator and brushes, by thermometer, 55° C.

Collector rings, 65° C.

Bearings and other parts of machine, by thermometer, 40° C.

(B) **ROTARY INDUCTION APPARATUS.** The temperature rise should not exceed the following:

Electric circuits, 50° C., by resistance.

Bearings and other parts of the machine 40° C., by thermometer.

In squirrel-cage or short-circuited armatures, 55° C., by thermometer, may be allowed.

(C) **STATIONARY INDUCTION APPARATUS.**

a. **TRANSFORMERS FOR CONTINUOUS SERVICE.** The temperature rise should not exceed 50 degrees Centigrade in electric circuits, by resistance; and in other parts, by thermometer.

b. **TRANSFORMERS FOR INTERMITTENT SERVICE.** In the case of transformers intended for intermittent service, or not operating continuously at rated load, but continuously in circuit, as in the ordinary case of lighting transformers, the temperature elevation above the surrounding air temperature should not exceed 50° C., by resistance in electric circuits and by thermometer in other parts, after the period corresponding to the term of rated load. In this instance, the test load should not be applied until the transformer has been in circuit for a sufficient time to attain the temperature elevation due to core loss. With transformers for commercial lighting, the duration of the rated-load test may be taken as three hours, unless otherwise specified.

c. **REACTORS, induction- and magneto-regulators** — electric circuits by resistance and other parts by thermometer, 50° C.

a. **LARGE APPARATUS.** Large generators, motors, transformers, or other apparatus in which reliability and reserve overload capacity are important, are frequently specified not to rise in temperature more than 40 degrees Centigrade under rated load and 55 degrees Centigrade at rated overload. It is, however, ordinarily undesirable to specify lower temperature elevations than 40 degrees Centigrade at rated load, measured as above.

(D) **RHEOSTATS.**

In **RHEOSTATS, HEATERS** and other electrothermal apparatus, no combustible or inflammable part or material, or portion liable to come in contact with such material, should rise more than 50° C. above the surrounding air under the service conditions for which it is designed.

a. **PARTS OF RHEOSTATS.** Parts of rheostats and similar apparatus rising in temperature, under the specified service conditions, more than

50° C., should not contain any combustible material, and should be arranged or installed in such a manner that neither they, nor the hot air issuing from them, can come in contact with combustible material.

(E) LIMITS RECOMMENDED IN SPECIAL CASES.

a. HEAT RESISTING INSULATION. With apparatus in which the insulating materials have special heat-resisting qualities, a higher temperature elevation is permissible.

b. HIGH AIR TEMPERATURE. In apparatus intended for service in places of abnormally high temperature, a lower temperature elevation should be specified.

c. APPARATUS SUBJECT TO OVERLOAD. In apparatus which by the nature of its service may be exposed to overload, or is to be used in very high voltage circuits, a smaller rise of temperature is desirable than in apparatus not liable to overloads or in low-voltage apparatus. In apparatus built for conditions of limited space, as railway motors, a higher rise of temperature must be allowed.

d. APPARATUS FOR INTERMITTENT SERVICE. In the case of apparatus intended for intermittent service, except railway motors, the temperature elevation which is attained at the end of the period corresponding to the term of rated load, should not exceed the values specified for machines in general. In such apparatus the temperature elevation, including railway motors, should be measured after operation, under as nearly as possible the conditions of service for which the apparatus is intended, and the conditions of the test should be specified.

The short-circuit characteristic, plotted between field and armature amperes, represents data obtained by short-circuiting the armature circuits through ammeters and noting the field current corresponding to two or three values of armature current. The curve is a straight line for all practical purposes. The curve gives a measure of the magnetic effect of the armature upon the field, combined with the armature losses. For example, on short-circuit at 50 armature amperes, 7.5 field amperes are required. The saturation curve shows this to correspond to 680 armature volts. At 50 amperes 680 volts have been consumed in armature impedance and in the weakening of the field by the armature.* In connection with the short-circuit curve is shown another plotted between armature amperes and corresponding kilowatts copper loss.

* The curve is required in order to rate an alternator in accordance with paragraph 209 of the Standardization Code. This paragraph briefly describes an empirical method for predicting the performance of alternators. While the method does not give general satisfaction it appears to be the simplest in application and furnishes a comparative if not absolute rating.

Alternator Handling. After an alternator has been properly installed it is only necessary to insure constant speed and reasonable load and to protect it from the effects of lightning disturbance.*

Synchronizing. When an alternator is to be connected in parallel with others already in operation, great care is necessary in closing the switches at the proper instant. The e. m. f. of the incoming machine must have the same fre-

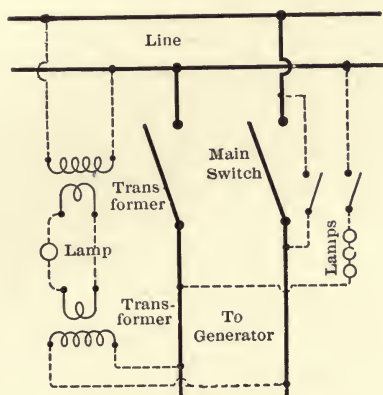

FIG. 87. Arrangement of lamps, with and without transformers, for synchronizing a. c. generators.

quency as the others. The e. m. f. waves must also be exactly in phase, otherwise the difference between any two instantaneous e. m. f. values will circulate a short-circuit current which may be injurious to the apparatus. In order to indicate to the operator the proper instant for closing the switches, various synchronizing devices are used. The simplest of these is a string of incandescent lamps, connected between the two machines, as indicated in Fig. 87, the number of lamps

* This has already been touched upon in Chapter IV, and will be discussed more fully in Chapter IX, Power Stations and Sub-Stations.

in series being sufficient to operate safely at twice the e. m. f. of the line. When the two e. m. f.'s are of the same frequency and exactly opposite each other in the synchronizing circuit, the lamps will be dark, when they assist each other the lamps will be bright. As the incoming machine approaches synchronous speed the light of the lamps "beats" or pulsates more and more slowly. When the dark periods last a few seconds the switches are closed and the operation is complete. Usually some cross-current will flow even with the most skillful operator but if this is not excessive no harm is done and the cross current tends to pull the revolving armature or field into exact synchronous speed. While simplest of all, this scheme requires the use of too many lamps for most cases, and the number is reduced to one by connecting the primary circuits of transformers to the generator and the line. Their secondary circuits are connected in series through the synchronizing lamp. Patented devices are also upon the market which indicate by the movement of a pointer upon a dial the proper instant for closing the switches. The latest development is a scheme for automatically closing the switches (automatic synchronizer).

Distribution of load among alternators is varied by changing the governor setting of the driving engines. A change in field strength of any one machine simply alters the phase position of its e.m.f. with respect to that of the others, and has no appreciable effect upon the amount of load which it takes. In this respect the parallel operation of alternators is radically different from that of direct current generators.

Balancing of phases of polyphase circuits is necessary in order to obtain the best performance from alternators. This can only be done by shifting load from one circuit to another, either at the switchboard or outside of the power station

Direct Current Generator Characteristics.

General Principles. The function of practically all d. c. generators is to maintain a constant e. m. f. or to produce a rising e. m. f. with increase of load. The shunt machine obviously cannot produce increasing e. m. f. automatically nor can it even maintain a constant e. m. f. Hence the compound-wound generator is used wherever good automatic regulation is required. In some cases, where hand adjustment of field current is not undesirable, shunt machines are employed. As a rule, however, compound-wound fields are preferred, not only for their regulating properties but also because generators so equipped "spark" less than plain shunt-wound machines. As an armature coil passes from one side of a brush to the other, its current is reversed and its inductance resists this reversal. In order to force the reversal the coil may have generated in it an e. m. f. opposed to its self-induced e. m. f. Such a reversing e. m. f. is produced by pushing the brushes forward, that is, in the direction of rotation,* until the coil is situated in a magnetic field of the necessary strength. Naturally this is called a "reversing field" on account of the service which it renders to the short-circuited coil. In order to secure good commutation this reversing field should be as stable as possible. This is not the case in a plain shunt machine as the armature m. m. f., increasing with the load, very greatly weakens it. In the compound-wound machine it is more stable on account of the increase of field m. m. f. with the load, the current passing around the series coils on the field. The brushes of the compound-wound machine need not be shifted as much as those of the shunt machine for a given change in the load. For

* The brushes are pushed backward (against the direction of rotation) in a motor as the current flows in the opposite direction with respect to the armature e. m. f.

loads of an extremely variable character, such as are imposed upon a generator by an electric railway, the compound-wound machine is absolutely necessary.

Commercial Compounding. Fig. 88 shows the performance of a compound-wound d. c. generator* similar to that illustrated in Chapter VI. On open circuit an e. m. f. of 525 volts is generated, and this increases with the load until when the armature is delivering 1700 amperes it produces 575 volts. The lower curve is taken with increasing, the upper with decreasing load, the difference being due to the retentive-

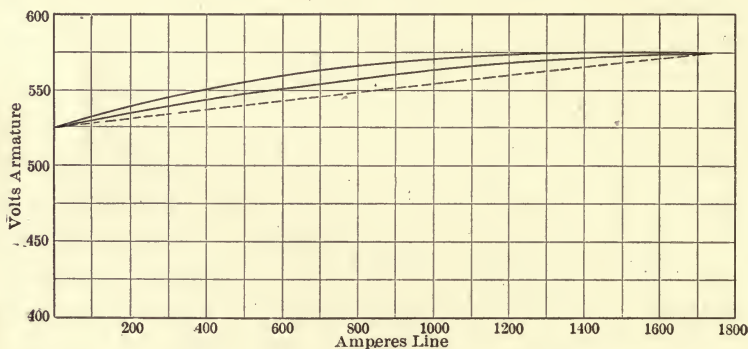

FIG. 88. Commercial compounding curve of d. c. generator (G. E. Co.).
Upper line with decreasing load, middle line with increasing load, dash line, perfect over-compounding.

ness of the iron in the magnetic circuit. A machine with sufficient series field turns to thus raise the e. m. f. with increased load is said to be *over-compounded*. The curves show that the e. m. f. does not rise in proportion to the current. The dash line connecting the ends of the e. m. f. curves represents perfect over-compounding, which cannot be secured automatically on account of the saturation of the magnetic circuit. Standardization Code, paragraph 198, states that

* The d. c. generator curves are used by courtesy of the G. E. Co.

“in over-compounded machines the regulation is the ratio of the maximum difference in voltage from a straight line connecting the no-load and rated-load values of terminal voltage as function of the load current, to the rated-load terminal voltage.” That is, the less the curvature of the curves, the better is the regulation.

Field Compounding. The number of series-field turns to be used is determined by a test yielding the data in Fig. 89. While the armature current is varied, the terminal e. m. f. is maintained constant at 575 volts by varying the shunt-field current. The curve shows that it requires in this case an increase from 12,300 to 14900 or 2600 ampere-turns to

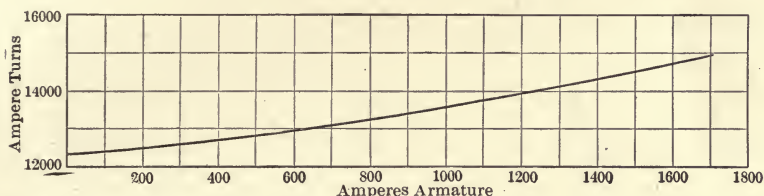

FIG. 89. Field-compounding curve, d. c. generator (G. E. Co.), showing field ampere-turns necessary to maintain 575 volts e. m. f. with varying load.

maintain e. m. f. against the armature resistance drop and the magnetic effect of the armature upon the field. The curve dips on account of the field saturation, more field m. f. being required proportionately with large than with small armature current.

Saturation. The saturation curve shown in Fig. 90 is plotted between field ampere-turns and armature e. m. f., which is proportional to the flux. The curve shows that the iron in the magnetic circuit begins to saturate at about 350 volts and the steepness of the curve decreases rapidly above 500 volts. This accounts for the bending of the compounding

curves already referred to. Fig. 91 exhibits the corresponding core loss (in hysteresis and eddy currents) for various armature e. m. f.'s.

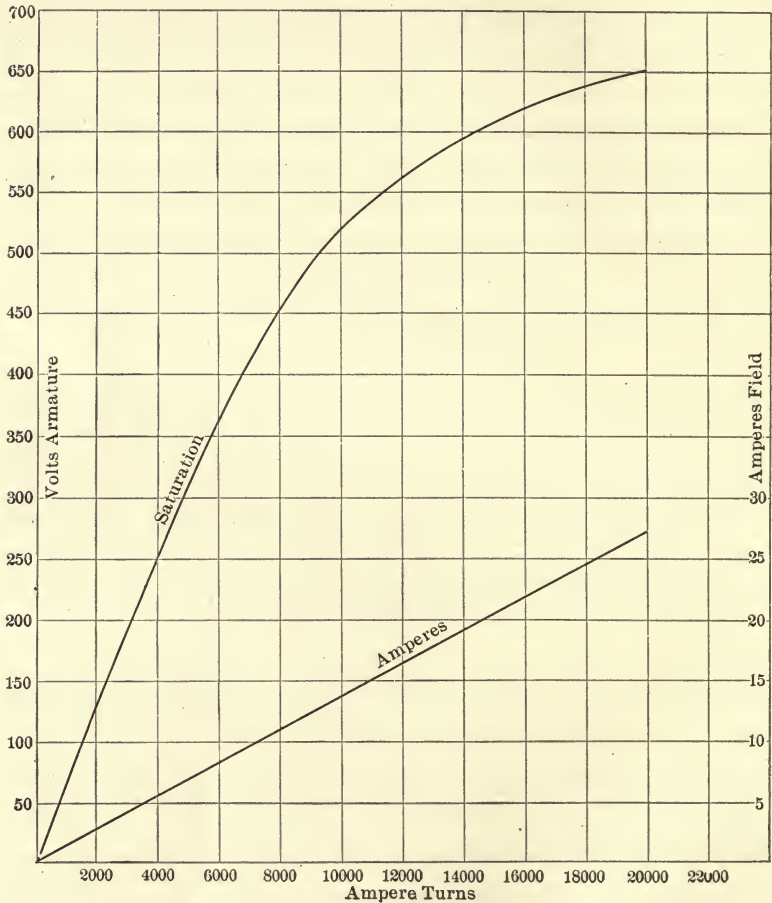

FIG. 90. Saturation curve of d. c. generator (G. E. Co.).

The efficiency curve, Fig. 92, gives the relation between per cent efficiency and per cent load and shows that above 50 per cent load the efficiency is practically constant at 95.5

per cent. On light loads the efficiency is low because field loss, armature-core loss and friction are proportionately large, amounting at 5 per cent load, or 85 amperes, to 30 per cent of the input or about 21.5 k. w. This indicates the import-

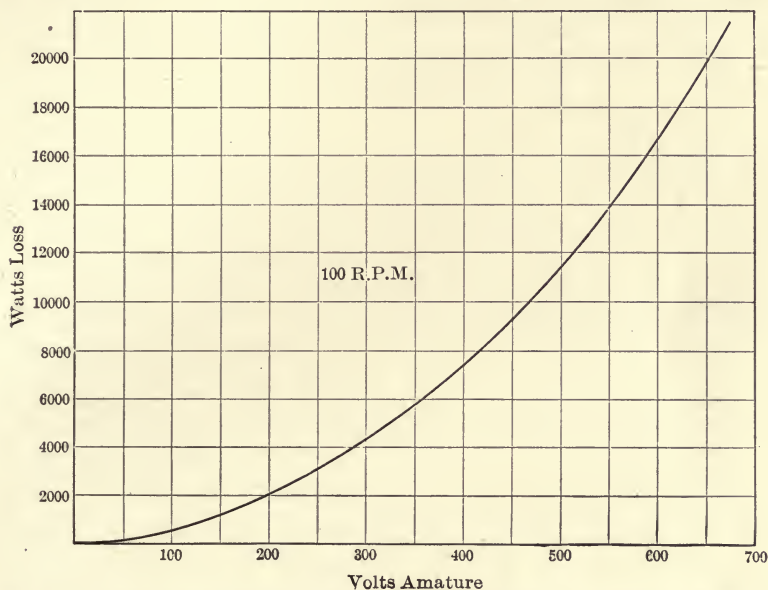

FIG. 91. Curves between core loss and e. m. f. (proportional to flux) in d. c. generator (G. E. Co.).

ance of operating these generators, and in fact all electrical machines, at as large a percentage of rated load as possible.

Handling Direct Current Generators.

The shunt field circuits of all d. c. generators are provided with resistances or "rheostats" for the purpose of permitting the variation of the current and thus adjusting the e. m. f. When shunt machines are operated in parallel the load is distributed by means of these rheostats or by varying the speed of the driving prime movers. Compound-wound generators

cannot be operated in parallel directly for the following reason. If one machine for any reason takes more than its share of the load its e. m. f. will automatically increase. It will take still more load, and in fact will almost immediately begin to operate the other generators as motors. To prevent

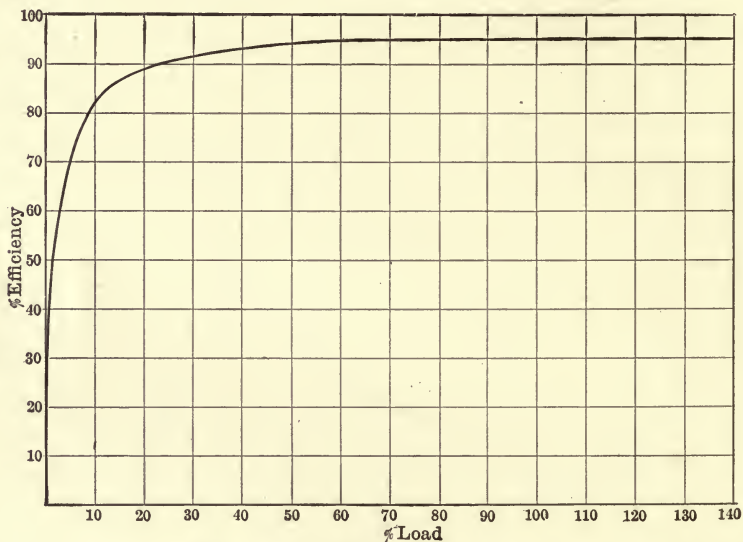

FIG. 92. Efficiency curves, d. c. generator (G. E. Co.).

this the series coils are all connected in parallel by a heavy bus bar known as an "equalizer" bar or bus. This insures the uniform distribution of the line current among the series coils, and hence if an increase of line current occurs all of the machines will increase their e. m. f.'s. alike and each will take its proper share of the increased load.

CHAPTER VIII.

TRANSFORMERS AND THEIR APPLICATIONS.

OUTLINE.

Transformer Construction:

Principles underlying Transformer Performance — Varieties of Transformers — Constant Potential Transformers.

Structural Features — Summary — Connections — Protection from Lightning — The Auto-transformer.

Series Transformers — Constant Current Transformers.

Constant Current Transformer — Constant Current Regulator.

Transformer Characteristics.

Constant Potential Transformer.

Regulation — Losses — Efficiency — Heating — Exciting Current.

Series Transformer.

Constant Current Transformer.

Transformer Installation — Transformers on Polyphase circuits.

Transformer Construction.

Principles Underlying Transformer Performance.

FARADAY'S ring, illustrated in Fig. 16, contains the principle of the transformer. Faraday found that when he connected one circuit to a battery a momentary current was produced in the other. A similar momentary secondary current was produced when the primary circuit was disconnected. If alternating current had been available at the time, Faraday would undoubtedly have applied his coil to the transformation of e. m. f., but it was not until fifty years later that this was actually done. In the intervening period all development was along the line of continuous current. Faraday's ring would

have made an imperfect transformer because the primary and secondary coils occupied different sections of the core, and the magnetic flux passed partly through the air between the coils. This *magnetic leakage* reduces the secondary e. m. f. and hence interferes with the regulation.

Principle of the Modern Transformer. An alternating current, furnished to one coil of a transformer, sets up an alternating magnetic flux in the core which cuts other coils located upon it. If there is no magnetic leakage the flux is the same throughout the core and *each turn thereon generates the same e.m.f.* The e.m.f. of all coils is, therefore, proportional to their numbers of turns. Magnetic leakage reduces the *ratio of transformation* by depriving the secondary coil or coils of part of the flux which is produced by the primary coil. In modern transformers the magnetic leakage effect has been reduced to an almost negligible amount by placing the primary and secondary windings very close together.

The term *primary coils* is used to designate those connected to the source of power. The *secondary coils* furnish current to the load. If the transformer is used to increase the e. m. f. it is a *raising* or *step-up* transformer. If it reduces the e. m. f. it is a *lowering* or *step-down* transformer.

Varieties of Transformers.

In general a transformer is a device for changing the form of electric power. The requirements of engineering practice cover the following varieties:

- (a) Transformation of constant alternating pressure at a fixed ratio, employing the *constant potential transformer*.
- (b) Transformation of alternating currents at a fixed ratio, employing the *series transformer*.
- (c) Transformation from constant alternating pressure to

constant alternating current, employing the *constant current transformer*.

(d) Transformation from constant alternating to constant continuous pressure, employing the *rotary transformer or converter*.

The word "constant" as used in this connection does not mean that the quantity so designated is absolutely constant as there is always some variation due to imperfections of the machinery.

Constant Potential Transformers.

Construction. Modern constant potential transformers are illustrated in Figs. 93, 94, 95, and 96. They are of two general types, Figs. 93 and 94 representing the *core type*, and Figs.

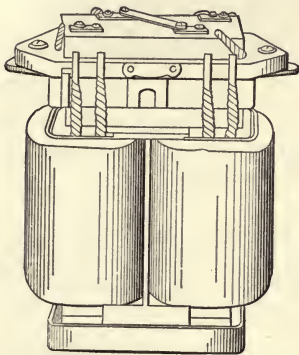

FIG. 93. View of small core type (G. E. Co. Type H) transformer.

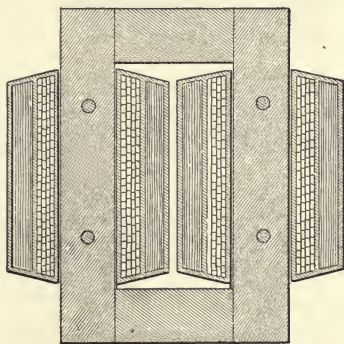

FIG. 94. Cross-section of coils and core of transformer shown in Fig. 93. (Section in plane of stampings.)

95 and 96 the *shell type*. The former has a rectangular core forming one magnetic circuit and the coils are placed upon the vertical limbs. The shell type has a "figure 8" form, two rectangles placed side by side, the center tongue carrying the

* As the rotary transformer is inherently a synchronous a. c. motor it is discussed under that head in Chap. X.

coils. This core contains two magnetic circuits in parallel. The cores are formed from stampings of thin electrical steel, bolted or clamped together, and insulated to prevent the cir-

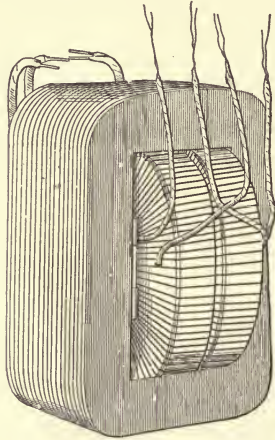

FIG. 95. View of shell-type (Fort Wayne Elec. Co., Type A) transformer.

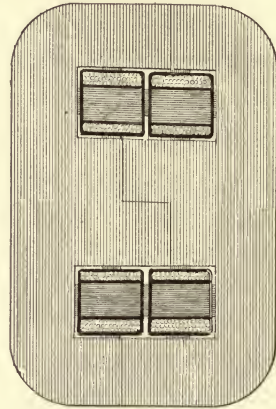

FIG. 96. Cross-section of coils and core of transformer shown in Fig. 95. (Section in plane of stampings.)

ulation of eddy currents. To minimize hysteresis, the steel with the lowest percentage of carbon is used and it is annealed with great care.

The coils are wound either in the form of concentric cylinders or in flat rings, primary and secondary coils being alternated to reduce magnetic leakage. The coils are wound with round or square cotton-covered wire and they are impregnated with insulating varnish or mineral wax compounds. They are taped and varnished when complete and are separated from the core and from each other by sheet fiber or micanite.

The complete transformer is mounted in a protecting iron case which is usually filled with oil. In some cases the oil is omitted and provision is made for rapidly circulating air

through the case and around and through the coils. These two practices give rise to the terms *oil-insulated* and *air-blast* transformers.

The terminals are carried through the case in rubber, porcelain, glass, or wood bushings. In outdoor locations the wires must be brought vertically downward under protecting eaves in order to prevent the entrance of moisture. In indoor transformers they may be brought out in the most convenient way. In high tension transformers the bushings are very elaborate and they form a troublesome part of the equipment.

Summary. The structural features of constant potential transformers may be summarized as follows:

1. The coils must be so related to each other that no magnetic flux passes through one which does not also pass through the other.

2. The insulation of the coils must be such that no electrical connection can exist between the coils or between a coil and the core.

3. The heat, which is necessarily generated in the coils and core, must be conveyed away without causing undue rise of temperature in any part of the transformer.

4. The losses of energy in coils and core must be kept low in order to insure high efficiency. This is especially true of the core, which must be magnetized at all times whether the coils are carrying useful current or not.

1. *Magnetic Leakage.* In order to insure the presence of the same flux in both coils, the latter are divided into sections and these sections are alternated in such a way that the turns are practically interlaced. In the constant current transformer the magnetic leakage is varied by allowing the coils to move under the action of the repulsive force between them.

2. *Insulation.* The insulation of the coils is made as perfect as possible as follows: The wires are individually insulated and the layers are separated from each other with proper material of great dielectric strength. Between primary and secondary coils are placed sheets of insulating material which will withstand the combined action of heat and electric pressure. In addition to all of this the transformer is usually immersed in oil which permeates all parts and greatly assists in improving the insulating properties of the other materials.

3. *Ventilation.* The oil, by circulation, carries heat from coils and core to case, which has walls of large surface and as thin as is consistent with mechanical strength. This is sufficient ventilation in small-sized transformers. The radiating surface per pound is evidently less as the transformer is larger. Hence in large sizes it is necessary to immerse in the oil, coiled pipes carrying cold water. In some cases the oil is dispensed with and air is forcibly circulated about the coils and core.

4. *The core and copper losses* are kept down as in the armatures of generators and motors by proper selection and application of magnetic and conducting materials.

Connections. The coils are usually wound in at least two sections with terminals brought to a connecting plate of porcelain or taken through bushings outside the case. High tension connections are, as a rule, made inside the case, and low tension connections outside. By making various combinations of primary and secondary coils the same transformer may be used for several operating conditions. For example, if there are two primary and two secondary coils, and each primary has 10 times as many turns as each secondary, and

if each primary coil is designed for 1000 volts they may be arranged as follows:

1. Primaries in series, secondaries in series, 2000 volts to 200 volts.
2. Primaries in series, secondaries in parallel, 2000 volts to 100 volts.
3. Primaries in parallel, secondaries in series, 1000 volts to 200 volts.
4. Primaries in parallel, secondaries in parallel, 1000 volts to 100 volts.

Transformers are frequently constructed with taps into the winding at various points so that the ratio of transformation may be changed by cutting out a number of turns. This is especially useful in power transmission work when it is desired to raise the e. m. f. of a line by a small amount without changing that of the generator. For example, in a certain railway substation it is desired to increase the e. m. f. on the low tension side of the lowering transformers, which are arranged normally to transform from 30,000 to 375 volts. Four hundred volts are required, and to obtain this increase the number of primary turns (high tension in this case) is *decreased* by

$$\frac{400-375}{400} = 6.25 \text{ per cent.}$$

Protection from Lightning. Transformer coils have a large inductance and, therefore, present a very great impedance or choking action to lightning discharges. They tend to reflect the discharges back into the line, which is usually provided with air gap lightning arresters. Before being reflected the electricity forming the discharge penetrates into the transformer winding a distance depending upon the severity of the disturbance. In doing this it very greatly strains the insulation upon the coils. In many transformers the *end*

turns are provided with extra heavy insulation to protect them from lightning effects.

The auto-transformer or single-coil transformer is a special type of constant potential transformer that is useful in special cases. If the primary winding of an ordinary constant potential transformer be connected to the line, the line e. m. f. will be consumed uniformly throughout its turns. That is, if it is a 1000-volt primary and has 1000 turns, a voltmeter connected across any part of the winding will indicate as many volts as there are turns included between the points of contact. Current may be taken off from these two points and the same winding will serve both as primary and secondary. Reversing this process, if a section of the turns be connected to line, the whole number may be used as secondary and the e. m. f. will be raised. For example, if 500 volts line e. m. f. be applied to 500 turns, 1000 volts may be used as secondary e. m. f. from the 1000 turns.

Series or Current Transformers.

If one of the coils of a constant potential transformer is connected in series with a circuit and the other is practically short-circuited, the secondary and primary currents will be proportional. The connections are as shown in Fig. 97. The most important application of this mode of connection is in transforming current for measuring purposes. For example, if an ammeter is short-circuited upon the secondary of the transformer, it will indicate a current which is equal to the primary current multiplied by the *inverse* ratio of turns. If one hundred amperes were the greatest current which a line carried and an instrument of 25-amperes range were the only one available it could be used by connecting in the line a transformer primary with any number of turns if the secondary has

four times the number. An arrangement of this kind is very convenient as it allows the construction of ammeters, wattmeters, watt-hour meters and electricity meters of standard sizes and limited range and these can be applied to any circuit

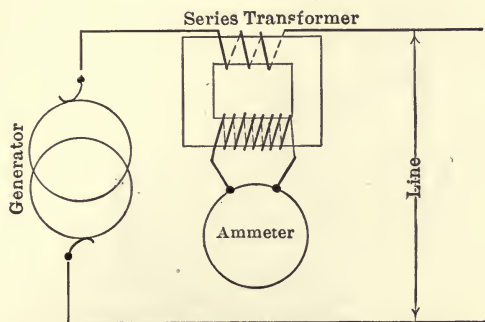

FIG. 97. Diagram of connections of series or current transformer in circuit.

by the use of the series transformer. Further, as the primary and secondary coils are insulated from each other the indicating instrument need not be connected directly in the high tension line. Series transformers are now made in small sizes only and in form convenient for switchboard work. At one time they were used for arc lighting and other purposes but have been superseded by simpler devices.

Series transformers are constructed under the same requirements as to core loss, ventilation, and regulation as constant potential transformers. It is not usually necessary to encase them as, on account of their small size, they readily radiate the heat generated.

Constant Current Transformers.

Arc lamps require for satisfactory operation a constant current. When the lamps are connected in series, the current in the circuit may be maintained constant by a regulating device.

The most important of these is the series or "tub" transformer. The primary of this transformer receives constant e. m. f. from the generator circuit and it maintains constant current in the secondary automatically, by the movement of the secondary

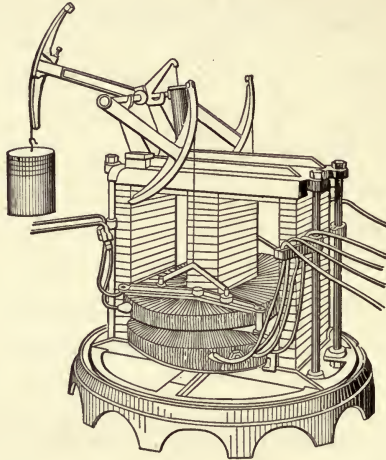

FIG. 98. Constant current transformer (G. E. Co.) showing coils, core, and counter-weight device.

coils. These are carried in guides and are supported from the end of a counter-weight arm provided with an adjustable counter-weight. The primary and secondary coils repel each other when they are carrying current and hence tend to take positions as far apart as possible. In this extreme position there is the maximum magnetic leakage, and hence the lowest ratio of transformation of e. m. f. When the coils are in contact there is minimum magnetic leakage, and hence highest ratio of transformation. The secondary coils are counter-weighted to such an extent that they "float" when under load, adjusting themselves automatically to a constant current over a wide variation in load resistance. The weights and coils are carried by chains or straps passing over adjustable cams which can be adjusted

to vary the length of the lever arms with the coil positions and thus magnify the effect of a change in position of the coils.

An elongated type of shell core is used in constant current transformers and the coils are flat and well protected from mechanical injury. The transformer is usually mounted in an oil-filled case, but small sizes may be operated satisfactorily unenclosed. The rating is made upon the basis of the maximum number of standard arc lamps for which the current can be regulated. The current is usually 6.6 amperes. A 25-light transformer will regulate for any number less than 25 that does not force the secondary coils to their minimum e. m. f. position. In a two-secondary type this will be when the two secondary coils strike each other, in a one-secondary type when the secondary coil strikes the core.

The constant current regulator is a device similar in action and purpose to the constant current transformer, but having only one coil, which is connected in series with the load. The coil moves over a core or *vice-versa*, the moving part being counter-weighted. The movement causes the coil to be surrounded by a greater or less amount of magnetic flux and correspondingly varies the *reactance* of the coil. The reactance controls the current in the circuit. The regulator is simpler than the transformer but the latter has the advantage in its ability to transform the e. m. f. at the same time that it is regulating the current. For example, a generator delivers 2200 volts to a line and a 35-lamp circuit is to be operated from it. Assuming that each lamp requires 85 volts and allowing for 10 volts line drop per lamp, 3325 volts will be consumed in line. There are three arrangements which will satisfy the requirements:

1. A 35-light transformer may be used and its primary and secondary circuits arranged with sufficient numbers of

turns to give the necessary maximum secondary e. m. f. (3325 volts.)

2. The lamps may be divided into two circuits and a regulator placed on each.

3. The e. m. f. may be raised to, say, 3500 volts in a constant potential transformer, and a regulator connected in series with the lamps in the secondary.

Transformer Characteristics.

Constant Potential Transformer Characteristics.

Regulation. The function of this type is to produce the rated secondary current without unnecessary falling off of e. m. f. The secondary current may vary in power factor as well as in amount. As stated in paragraph 197 of the Code, "the regulation is the ratio of the rise in secondary terminal voltage from rated non-inductive load (at constant primary impressed terminal voltage) to the secondary terminal voltage at rated load." Further, the transformer must operate without excessive rise in temperature, such excessive rise being injurious to the insulation, causing increase of resistance and rendering the core iron liable to "ageing." Code, paragraphs 283 and 284, recommend the allowance for temperature rise, measured by increase in resistance of the coils, not to exceed 50°C. above the surrounding air.

The following table * gives the regulation at full load for the shell type of transformer illustrated in Figs. 95 and 96.

For other loads the regulation is found by simple proportion.

The table indicates that the regulation is best for unity power factor and that it is worst in this case at 80 per cent power factor. The magnetic leakage of the transformer produces reactance which consumes e. m. f. and thus interferes

* This table and the curves of Figs. 99, 100, and 101 are used by courtesy of the Fort Wayne Elec. Works.

with perfect regulation. The fact that this reactance cannot be very great is evidenced by the fact that even in the worst case the combination of resistance and reactance (impedance) causes a rise of but 3.1 per cent when full load of the most unsatisfactory power factor is thrown off. It should be noted that the maximum rise will not necessarily occur at the same power factor in other transformers. The power factor at which it occurs depends upon the resistance and reactance (caused by magnetic leakage) in the transformer coils.

REGULATION OF 60-CYCLE, 5 K.W., TRANSFORMER.
 PRIMARY VOLTS 1100/2200.

PER CENT. POWER FACTOR.	PER CENT. REGULATION FULL LOAD.
100	2.0
95	2.5
90	2.8
85	3.0
80	3.1
75	3.0
70	3.0

Losses. The characteristic curves of the same transformer are shown in Figs. 99, 100, and 101. Fig. 99 contains curves of the power losses with different secondary loads of unity power factor. The core loss (63 watts) is the same at all loads, as the frequency and density of flux remain constant. The secondary load increases from zero to 27 amperes, the primary current increasing practically in the same proportion. The copper losses vary as the square of these currents. The total losses in this transformer, therefore, increase from the core loss with secondary on open circuit in accordance with the curve marked "total loss."

Efficiency. Fig. 100 shows the efficiency for the same transformer. This is the ratio, in per cent, of the output to the sum of the output and losses. The efficiency reaches its maximum value, in this case, at about three-fourths load.

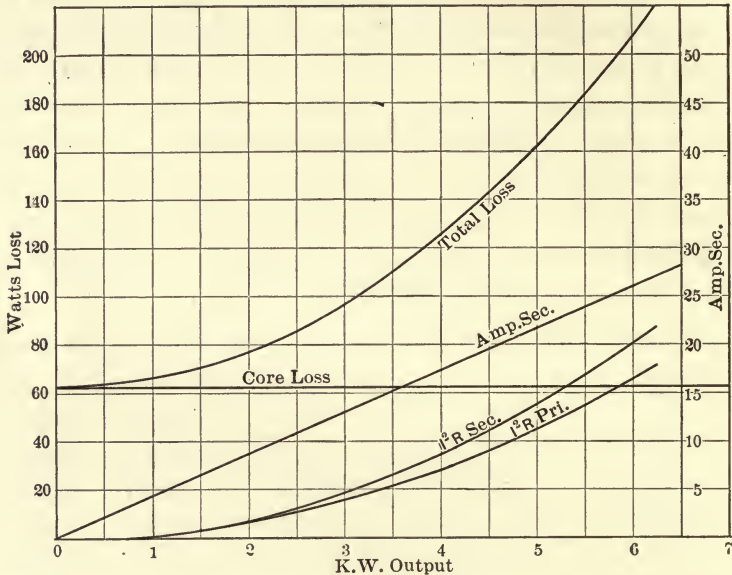

FIG. 99. Curves showing variation of transformer losses with secondary current (Fort Wayne).

In any transformer the location of the maximum efficiency point depends upon the relation of the iron and copper losses. A transformer may, therefore, be designed to suit a large or small average load. For example, a transformer, which is to supply its full load current continuously to an electric furnace will be designed for a high efficiency upon full load. Another, which will be loaded ordinarily to but one-fourth its normal full load, will be designed for high efficiency upon light load. The former may have a comparatively large iron loss, the latter must have a comparatively small iron loss.

Heating. Fig. 101 represents a "heat run" on this same transformer. The temperature continues to rise for a number

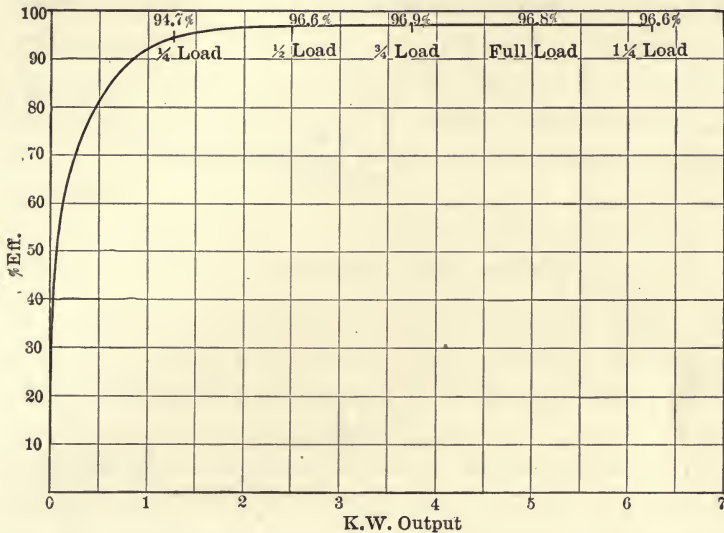

FIG. 100. Curve showing variation of transformer efficiency with load (Fort Wayne).

of hours. As transformers are usually employed for intermittent service it is unlikely that the equivalent of a continuous load will ever be applied to them. Hence, for example, for lighting purposes a transformer may be considered safe if the rise at the end of a three-hour run does not exceed the allowance. The curves show that a greater rise is indicated by resistance increase than by a thermometer in the oil. This is due to the greater temperature which exists in the interior of the coils.

Exciting current in constant potential transformers. When the secondary circuit is open a certain current flows into the primary for the purpose of:

- (a) Magnetizing the core.
- (b) Supplying the core losses.

This is the *exciting current* and as it flows continually for 24 hours per day, and as it does not register upon the consumer's meter, it is a matter of importance to the supply company.

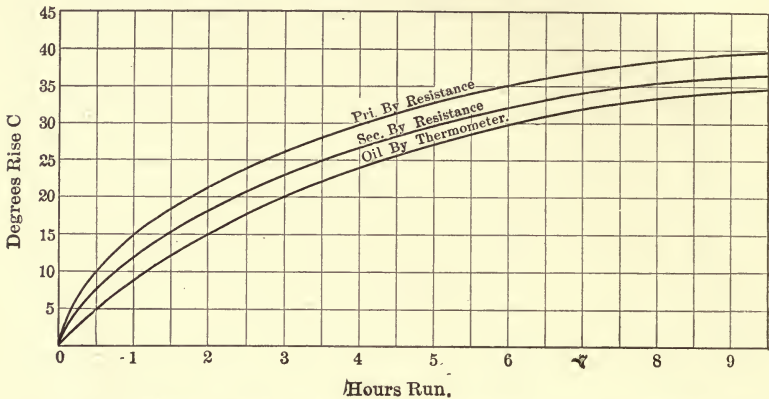

FIG. 101. Curves showing increase of temperature with duration of load in transformer (Fort Wayne).

The *magnetizing component* of the exciting current represents no loss of power as it is in quadrature with (or 90° behind) the line e. m. f. The *core loss component*, however, is a power loss. Take for example, the transformer performance shown in Fig. 99. The "all-day" loss is 63 watts whether any secondary current is flowing or not. 63 watts for 24 hours is 1513 watt-hours, or, say, 1.5 k. w. hours per day, or 548 k. w. hours per year. As the selling price of this energy would be at least 10 cents per k. w. hour, the company loses what might have been sold for \$54.80. Of course the company does not lose this much, as the loss is computed in determining the selling price of the energy. Obviously it is not the power efficiency of a transformer, but rather the *energy* efficiency which is most important. The latter is frequently called the *all day* efficiency to distinguish it from the former. As an example of the calculation of all-day efficiency, suppose

that the transformer, which is shown in Fig. 99, operates for three hours at full load (5 k. w.) during a day. The energy loss in the copper is (from the curves) $(55 + 45) \times 3$ or 300 watt-hours. The all-day core loss is 1513 watt-hours and the total all-day loss, 1813 watt-hours. The output is 15,000 watt-hours, the input 16,813 watt-hours and the actual corresponding all-day or energy efficiency is approximately 89.2 per cent.

Series Transformer Characteristics.

The important curves for series transformers are those showing the relation of primary and secondary current at all values of load. As these devices are usually constructed for operation with particular instruments, which are calibrated in connection with the transformers, the regulation is not a matter of interest to others than the manufacturers, assuming that the instruments indicate correctly under specified operating conditions. When a series transformer is to be used independently its curves should be obtained.

Constant Current-Transformer Characteristics.

Given a constant primary e. m. f., this type of transformer should deliver a constant current. Obviously this current cannot be absolutely constant as a change is necessary to cause the regulating mechanism to operate. This change is so slight as to be entirely negligible, and the current may be considered as constant for all practical purposes. By adjustment of the counter-weights the current may be made to increase or decrease with the load, but this is seldom desirable. The variation of current with e. m. f. (that is with the number of lamps in series) will follow a straight line law.

Transformer Installation.

Transformers are treated as a considerable fire risk and for this reason are placed preferably out of doors. When necessarily installed indoors they are preferably mounted in a brick or other fire-proof chamber with ventilation to the out-door air. A satisfactory plan is to place the transformers in out-door manholes with underground service connections. In Fig. 102 is shown an excellent pole mounting of the transformer previously discussed. The iron case is bolted to two strap-iron hooks which hang from the upper cross-arm and rest against the lower. The current is received from the line through fused "cut-outs" which serve both as switches for opening the circuit and as over-load protecting devices for the transformer. The wires enter and leave the case under projecting eaves, passing through insulating bushings.

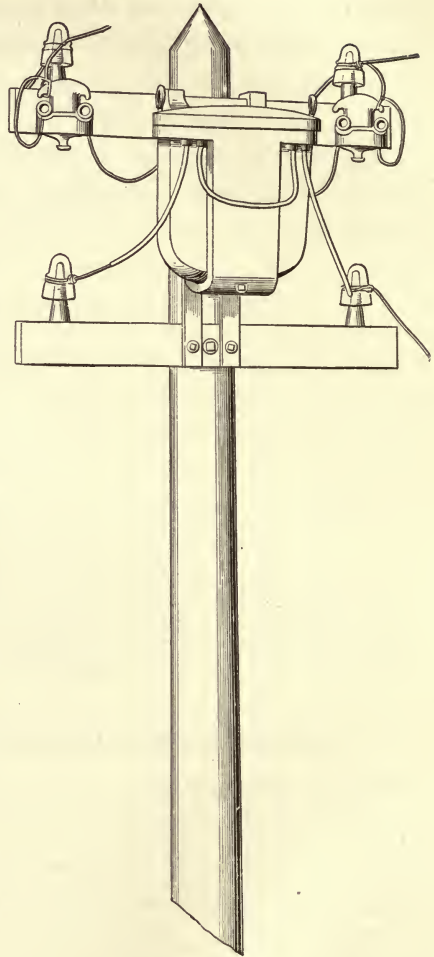

FIG. 102. Transformer (Fort Wayne) mounted on cross-arm, showing method of connection of primary circuit to line.

When transformers are very large it may be necessary to mount them in-doors. In this case they should be installed in such a manner that, should the oil become ignited it may burn without endangering surrounding property. While it is not likely that the transformers will ignite themselves, it is a possible contingency. When a short-circuit occurs, if the protective devices do not act promptly, a large amount of heat will be generated in a small space and much damage may result. Further the presence of a large volume of oil is in itself a risk as it is apt to be ignited by a fire originating outside.

The *grounding* of the middle or neutral point in the secondary winding of a transformer is often desirable in reducing fire risk and danger of life when the primary is accidentally grounded. With a grounded neutral it is impossible for the secondary to attain a potential above the ground greater than the e. m. f. produced in one-half its turns. Usually this will not be a dangerous e. m. f.

Transformers on Polyphase Circuits.

Two or three phases may be transformed on a single core provided that there are at least two paths for the flux which passes through any one pair of primary and secondary coils. Two transformers are, however, invariably employed with two-phase circuits and usually in this country three are used with three-phase circuits. Each phase of a two-phase circuit is treated as a separate single-phase circuit. The primaries may be arranged either in Δ (mesh) or Y (star) connection, as may also the secondaries. The Δ -connection has the advantage that one transformer may be removed without interfering seriously with the operation, the remaining transformers combined producing very nearly the e. m. f. of the missing transformer. This is convenient in case of accident

as it obviates the necessity of disconnecting the entire "bank" or set of transformers in case of accident to one of them. A

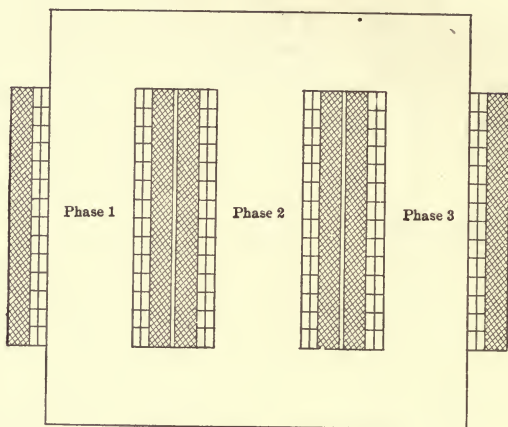

FIG. 103. Core and coils of core-type three-phase transformer (Westinghouse).

three-phase core and windings is shown in Fig. 103. The primary and secondary coils may be connected as if they were mounted upon separate cores.

In 1893 when the Niagara Falls power projects were under way there was much discussion as to the relative merits of two-phase and three-phase machines. Three-phase circuits were preferred for transmission as they are more economical of copper, but many engineers preferred two-phase generators and motors. An invention of Mr. Charles F. Scott simplified the situation by providing an efficient means for transforming from two to three-phases or *vice versa*. As shown in Fig. 104 the secondaries of two-phase transformers may be arranged in *T-connection*, that is the end of one is tapped into the middle of the other. The three resulting terminals will then be the terminals of a three-phase circuit, and if secondary *c* contains

a number of turns equal to $\sqrt{3}$ times the number in a or b , or $\frac{\sqrt{3}}{2}$ times the number in $a + b$, the three e. m. f.s will be equal

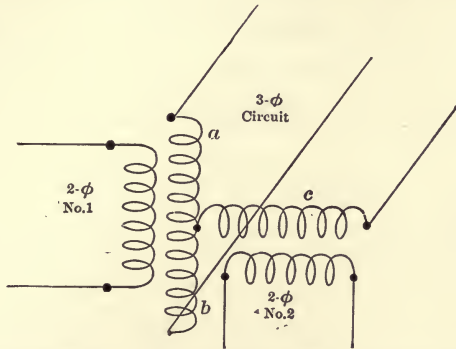

FIG. 104. The "Scott" or "T" connection of transformers for changing from two to three phases or *vice-versa*.

and equally displaced from each other in phase position. The diagram in Fig. 104 indicates the vector diagram representing

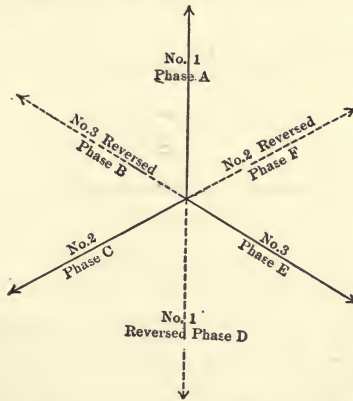

FIG. 105. Diagram of three-phase, six-phase transformation, by reversal secondary terminals of transformers.

the Scott transforming system. The transformation will take place either way, that is from two to three or from three to two phases.

Polyphase currents may be transformed in an almost indefinite number of combinations largely through the ability to reverse the secondary connections of the transformers. As an example, it is often desirable to produce six phases from

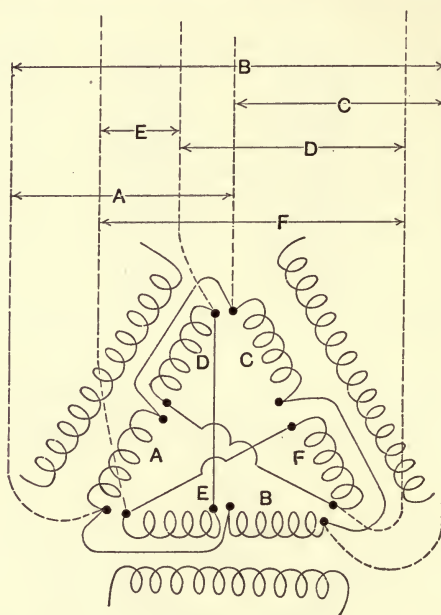

FIG. 106. Transformer connections for three-phase, six-phase transformation.

three. As shown in Figs. 105 and 106, if each e. m. f. of a three-phase circuit is reversed (shifted through 180°) there will be a total of six e. m. f.'s displaced by 60° . This is accomplished by the use of three transformers with double secondaries. Each set of three secondaries is connected in Δ and the six-phase circuit with six wires is taken off from the six junctions as indicated in Fig 106. This case will serve to illustrate the possibilities of phase transformation.

CHAPTER IX.

CONSTRUCTION AND OPERATION OF POWER STATIONS.

OUTLINE

Power Station Construction.

Introduction — Elements of Stations — Source of Power — Power Auxiliaries — Switchboards and other Electrical Auxiliaries — Battery Auxiliaries.

Electrical Auxiliaries in Power Plants:

Lightning Protection — Ground Detectors — Switches and Circuit Breakers — Switchboards.

Examples of Plant Construction:

Reciprocating Steam Engine Plant — Steam Turbine Plants — Vertical Type — Horizontal Type — Hydro-electric Plants — Impulse-wheel Plant — Turbine Plant — Gas Engine Plant — The Storage Battery.

Operation of Power Stations.

Function of the Power Station:

Power Station Characteristics:

The Load Curve — The Load Factor — Lighting load Curves — Railway load Curves — Effect of the Storage Battery.

Power Station Economics:

Cost of Producing Electrical Energy — Station Records — Effect of Load Factor — Charging for Electrical Energy.

By the term power station or power plant is meant that part of the electrical and mechanical equipment in which the electrical power is originally generated. It is the "heart" of the system. A substation is one in which the power is transformed for local distribution. It is connected with the power plant by the transmission line.

The elements of all stations are:

1. **The Source of Power.** This may be boiler and engine, water wheel, gas or oil engine, synchronous motor or induction motor. The proper one to use is that which, in the end, will deliver energy most cheaply at the receiving apparatus.

2. **The Electric Generators.** The different varieties have been covered in Chapter VI. The type for a particular case is selected with a view to economical transmission and application of power. To a certain extent the receiving apparatus affects the selection of the generator, but this is not the controlling influence as it is practicable to transform any one variety of current to any other. The economy of transmission is most important when the power is to be transmitted over any considerable distance. Two general forms of practice in stations may be noted.

(a) The use of separate generators for the different varieties of current needed. This is the general plan in use in substations and in power plants located near the receiving apparatus. An example of the latter is in *isolated* plants, such as those in large office buildings.

(b) The generation of a standard form of power which is afterward transformed to the different varieties required. This is the practice in all large plants at the present time. The power is more efficiently produced in large units than in small ones and even if different varieties of current are needed in the vicinity of the station they are usually produced in transforming devices located in the station.

3. **The Power Auxiliaries.** In connection with the prime movers there are various devices for increasing station economy. The use of such devices as economizers, feed heaters, purifiers, stokers, etc., is to be decided upon from the stand-

point of financial economy, taking into account interest on first cost, depreciation, and expense of operation.

4. The Switchboards and Other Electrical Auxiliaries. These are most essential features of a station, and the arrangement of generator, feeder, and transfer switches, ammeters, voltmeters, circuit breakers, fuses, etc., must be carefully determined. As a general consideration it may be said that the switchboard must be designed to fit the machinery, to provide for transfer of feeder and generator circuits, both to avoid shut-down and to properly distribute the load. It should also be provided with such measuring instruments as will enable machines to be economically operated and to give a measurement of the daily energy output.

5. The Battery Auxiliary. In modern stations the installation of a battery is always considered, and frequently a battery is installed to act as an energy reservoir for emergencies and to serve as a load regulator. A battery, properly installed, may have a marked influence upon the economy and reliability of the operation of a station.

Electrical Auxiliaries in Power Plants.

All varieties of power plants have certain features in common. The electrical equipment must be protected from lightning disturbance; the current must be controlled by devices for opening the circuits when there is danger to apparatus from over-load; switches must be provided for transferring the load from one circuit to another or for disconnecting generator and load circuits.

Lightning Protection. Dr. Steinmetz thus summarizes the present views of lightning disturbances in electric circuits:*

“ In its most general meaning, as understood now when

* Proc. A. I. E. E., from paper delivered at 217th meeting, March 29, 1907.

dealing with electric circuits and their protection, *lightning denotes all phenomena of abnormal voltage and abnormal frequency.*

The lightning phenomena in electric circuits then comprise:

External lightning, the disturbances due to atmospheric electricity.

Internal lightning, the disturbances due to defects of the circuit or its operation, etc., and

Surges, that is, disturbances in the flow of generated power, brought about by the external or internal lightning, and depending for their energy on the power of the generator system, hence frequently destructive.

The phenomena of abnormal voltage and frequency in electric circuits are the same three classes of phenomena met with in the disturbances in any medium which is the seat of energy:

1. Steady stress or gradual electric charge.
2. Impulse or traveling wave.
3. Standing wave or oscillation and surge."

In order to relieve the stress due to these disturbances the abnormal charge of electricity in the circuit must be allowed to escape to ground without short-circuiting the line. A plan for doing this is illustrated in Fig. 36, Chapter IV. A grounded wire is separated from the line wire by a short distance across which the discharge jumps rather than pass through the highly inductive apparatus in the circuit. This is the "horn" arrester, used to a large extent on transmission lines. In power stations and sub-stations a different type is in general employed. A number of knurled brass cylinders are mounted in straight or zig-zag rows, adjacent cylinders being separated by a few hundredths of an inch. Brass is a "non-arcing" metal; that is an arc is maintained with great difficulty between terminals of this or other zinc alloys. The combination of

cylinders and gaps, named a "multi-gap" arrester, is illustrated in Fig. 107. For low values of line e. m. f. a number

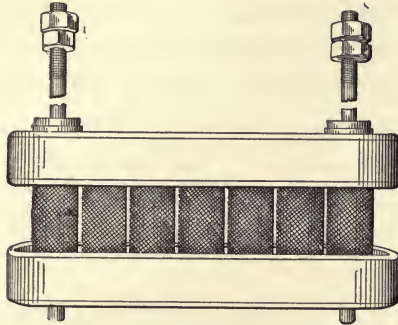

FIG. 107. Small Westinghouse multi-gap lightning arrester.

of these gaps may be simply connected in series between the line wires and the ground as indicated in Fig. 108. Usually a

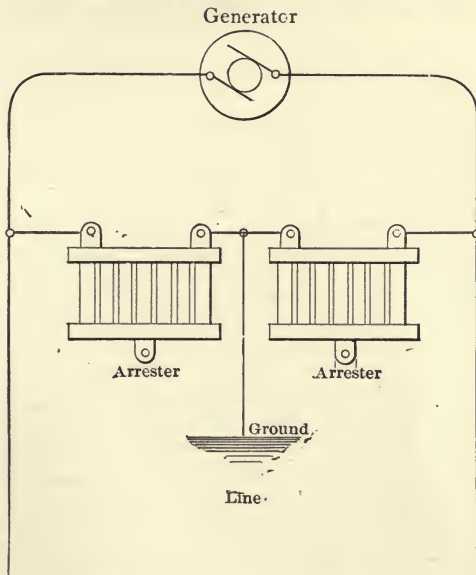

FIG. 108. Lightning arresters connected to line and ground.

few turns of wire, known as a "choke coil" are connected in the line wire between the generators and the arrester in order

to force the discharge to pass across the gaps. As the lightning disturbances are usually of high frequency, it is easier for them to jump across the air gaps than to overcome the reactance of the choke coils. It has also been experimentally determined that multi-gap arrestors are more reliable when shunted with resistance as shown in Fig. 109,* which illustrates the latest developments in "shunted gap" arrestors. The whole matter of lightning arrestors is one presenting the greatest difficulty as the disturbances are of very high and

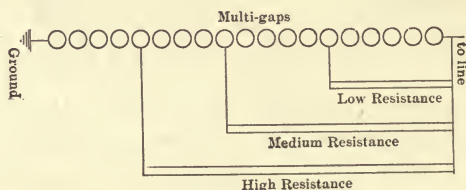

FIG. 109. Shunted, multi-gap lightning arrestor.

unknown frequencies and of uncertain quantity. Much remains to be done in perfecting the arrestor equipment.

Ground Detectors. Any part of an electric circuit is liable to become connected with the ground directly or indirectly. This throws the entire dielectric stress upon the insulation of the other conductor or conductors forming the circuit. In order that the presence of such a "ground" may be detected, an arrangement of lamps or voltmeters, known as a "ground detector," is located in the power plant. A good plan for low e. m. f. is shown in Fig. 110.† An accidental ground on the circuit is supposed to occur at *a*. No interruption of the service is caused by the "ground" until another develops at *c*. The line is then short-circuited and the fuses are melted.

* The figure is from a 1907, A. I. E. E. paper on Protection against Lightning by Messrs. Rushmore and Dubois.

† From hand-book of the Assn. Fact. Mut. Fire. Ins. Cos.

The ground at *a* is discovered by placing one voltmeter switch lever on point 1 and the other on point 3, which is connected to ground through wire *b*. If the "ground" has practically no resistance the voltmeter will indicate the full line e. m. f. If the resistance of the "ground" is the same as that of the

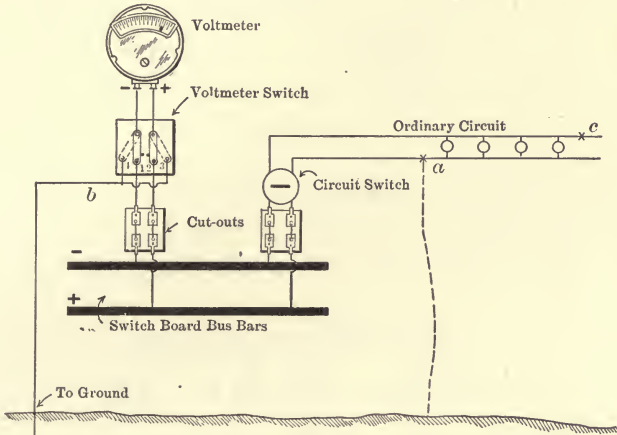

FIG. 110. Voltmeter and switches arranged for detecting "grounds" in electric circuits.

voltmeter, the e. m. f. indicated will be one-half that of the line. From the voltmeter resistance and the reading when it is grounded an approximate calculation of the "ground" resistance may be made.

Voltmeters or lamps may be permanently connected between the wires and ground and an indication of trouble will be given by the lighting of the lamps or the movement of the voltmeter needle. For high alternating e. m. f.'s the lamps or low pressure voltmeters may be connected through transformers, or a voltmeter of the electrostatic type may be employed.

Switches and Circuit Breakers. The simplest device for opening a circuit is a blade of copper, hinged at one end and

making contact between flexible copper jaws. (See Fig. 111.) Such a switch, with its parts properly supported upon insulating material (marble, porcelain or slate), and with the length

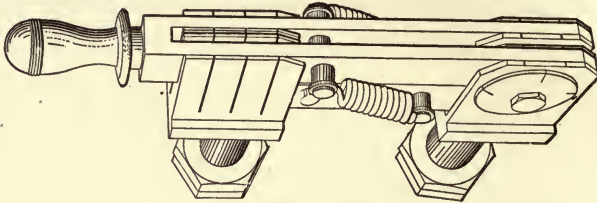

FIG. 111. A quick-break switch.

of "break" properly proportioned to the e. m. f. of the circuit, can be used to open circuits with moderate e. m. f. and current. Such a switch is adapted to "transfer" purposes at much

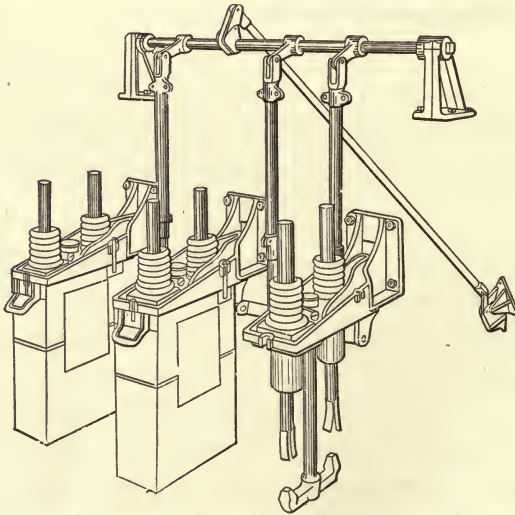

FIG. 112. A three-phase oil-break switch, with one oil cell removed.

higher e. m. f. By *transfer* is meant the connection or disconnection of circuits when not under pressure or carrying current. Obviously, a switch which can be depended upon to

open a circuit of 500 volts e. m. f. and carrying 100 amperes can be used to transfer "dead" circuits that will later be subjected to several thousand volts e. m. f. with the same current. It is the opening of a switch under current that renders it liable to short-circuit and burning. Open knife switches as described are not commonly used for circuit-breaking purposes above 500 volts and a few hundred amperes. Such switches, when immersed in oil, are available for very high e. m. f.'s and are in general use as circuit-breakers, either automatically or manually operated. Instead of the knife blade type of switch, the plunger type is well adapted to high tension work when oil immersed. The plunger switch comprises a metal plug drawn into and out of a split tube by a lever mechanism.

In large power plants it is usual to have the switches and circuit-breakers located away from the control board in fire proof chambers. The operation of the switches is by electric motors, solenoids or air cylinders, under the control of the switchboard attendant. The heavy bars and high tension wires may be placed in the best positions, with a view to economy of material and ease of insulation. The operating board is thus reduced in size and may be placed to the greatest advantage.

Switchboards. Marble panels or frames of metal and wood upon which instruments and switches are mounted, is given the general name *switchboard*. There is infinite variety in form and arrangement of such equipment, each plant having its own peculiar requirements. In general, these switchboards are designed to provide accommodations for ammeters, voltmeters, watt meters, watt-hour meters and special instruments, and such switches and circuit-breakers as are necessary to open the generator and feeder circuits either under load or when idle. If the main switches are too large to be mounted upon the switchboard, the control switches are arranged upon

a special operating board or table and indicators show the condition of the main switches.

The control equipment is located in a position from which the generators are visible, usually in a gallery well above the operating floor. The equipment is in charge of one or more attendants whose duty it is to prevent over-loading of machines, to synchronize and cut out generators as required to meet the demands of the load and to keep watch over the output of the station insuring proper regulation of e. m. f. and continuous service to customers.

Examples of Plant Construction.

Reciprocating Steam Engine Plants. Figs. 113 and 114 illustrate the standard practice in stations of moderate size. In Fig. 113 the coal supply is at the left and the electrical energy is sent out to the line from the switchboard at the right, the energy having passed from the chemical form, through the thermal and mechanical to the electrical. Coal is delivered from an overhead track to the storage space in front of the boilers, into which it is fed by hand. Four water-tube boilers of 3000 square feet heating surface each furnish steam at 150 pounds pressure to two 850 horsepower cross-compound condensing engines. The 500 k. w. three-phase, 25 cycle, 2300 volt generators are direct connected to the engines between the high and low pressure sections. At rated load the engines produce a horsepower hour on 14.1 pounds of dry steam at 26 inches of vacuum. The generating units are designed for a continuous maximum load of 1500 horsepower and a momentary load of 1700 horsepower.

Steam passes from the boilers through 6-inch boiler leads, with valves at both ends, to a 12-inch header located several feet below the boiler outlets. This header acts as a steam reservoir and allows the precipitation of moisture from the

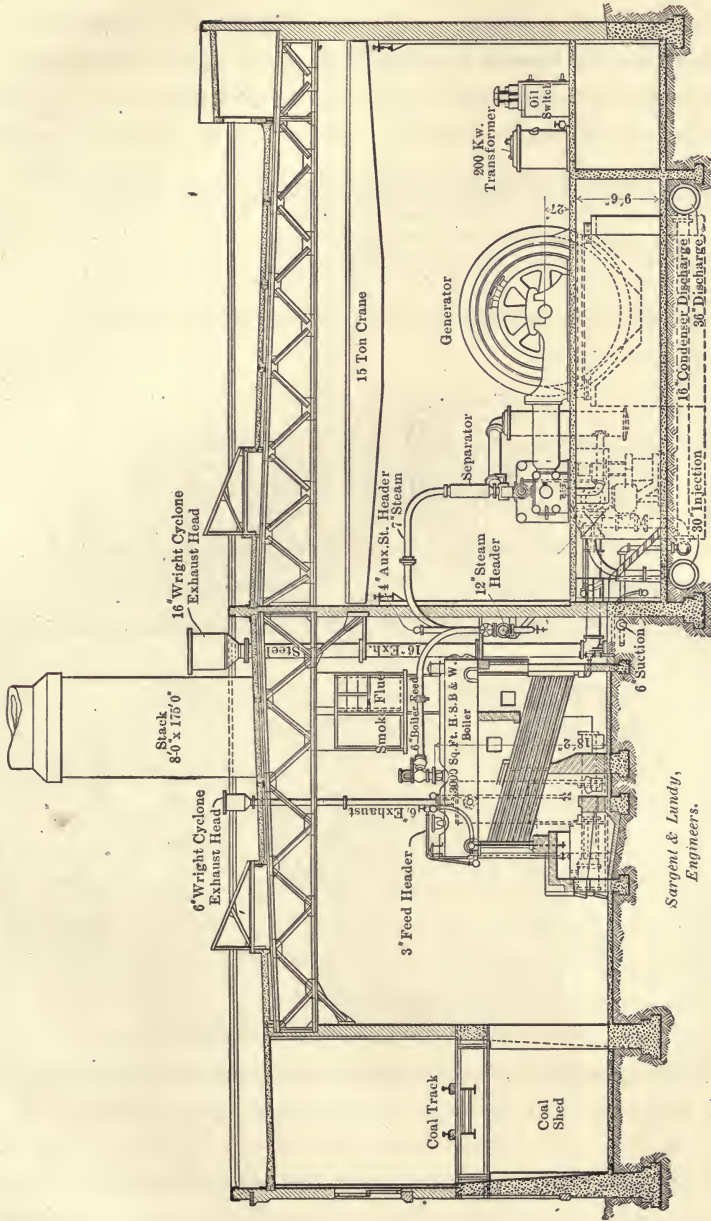

FIG. 113. Cross-section of the power plant of the Winona Ry. Co., illustrating reciprocating engine practice.

steam. Drips are located at the ends and middle of the header. Above the main header is a 4-inch auxiliary one for emergency use and also serving as a supply for the exciter engine. From the tops of the main header 7-inch arched engine leads, with

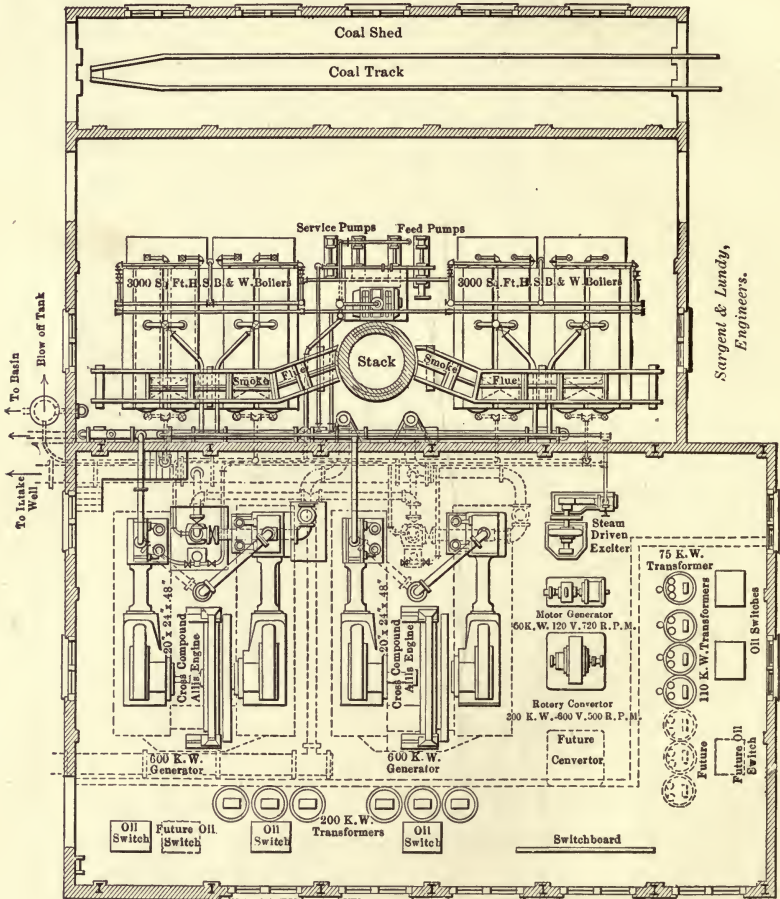

FIG. 114. Plan of the power plant of the Winona Ry. Co.

valves at both ends, convey steam to the main engines. The steam is dried in separators just as it enters the engines. From

the engines the steam passes to jet condensers, or to the atmospheric exhaust in case of disability of the condensing apparatus, or when it is desired to supply exhaust steam for district heating purposes.

The speed of engines and generators is approximately 94 r. p. m. requiring 32 poles on the generator for the frequency of 25 cycles per second. There are two exciters, each of 50 k. w. capacity, one driven by a high speed steam engine, the other by an induction motor. The electrical output of each generator passes to a bank of three 200 k. w. oil-insulated, water-cooled, delta-connected transformers, in which the e. m. f. is raised to 33,000 volts for transmission. From the transformers the conductors lead through oil-immersed, electrically controlled switches to the high tension line.

A substation is located under the same roof as the power plant for the purpose of supplying 600-volt direct current for local railway purposes. The equipment for this is the same as in the sub-stations located along the line. It consists of a 300 k. w. rotary converter, supplied with three-phase current at 375 volts from the high-tension line through a bank of three 110 k. w. transformers.

The station described is typical of those of modern construction and moderate size. In smaller plants the high speed engine is frequently used and power is generated in the form required by the receiving apparatus. When the plant is for lighting service only single-phase generators may be preferable especially if the load is not distributed over a wide area. In stations of great size vertical, or combined vertical and horizontal engines are used in order to economize floor space. The latter type also gives more uniform rotative effort. In such plants numerous economizing devices, not practicable in smaller ones, are necessary in order to obtain maximum plant efficiency.

Steam Turbine Plants. Vertical Type. A typical steam turbine plant of large size is shown in Figs. 115 and 116. These

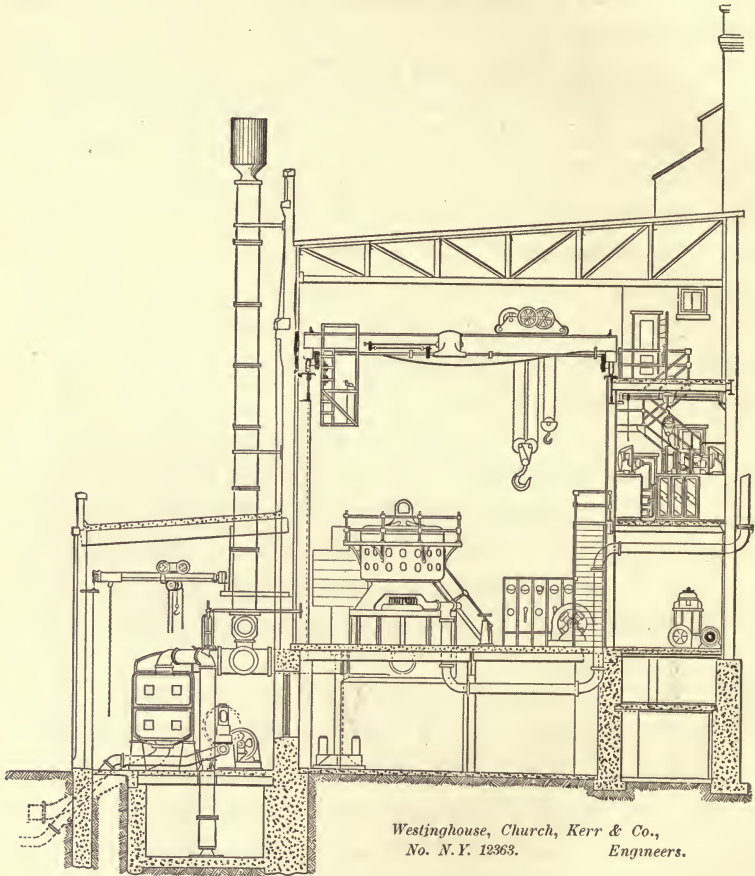
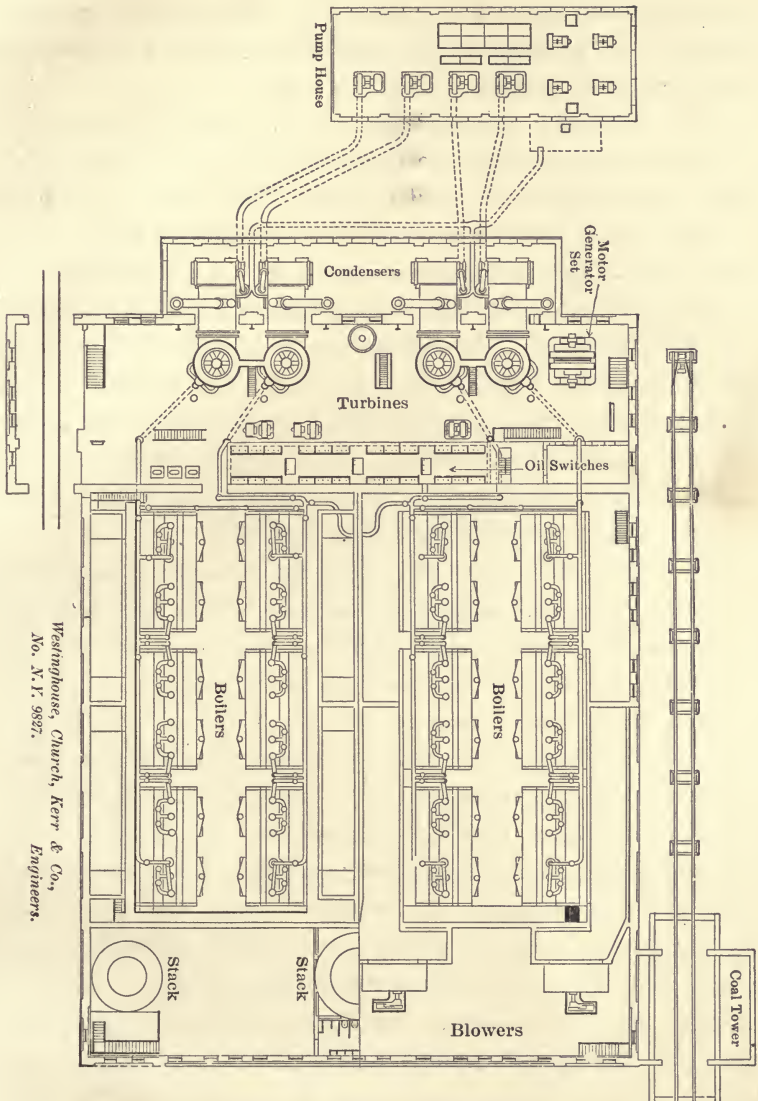

FIG. 115. Section of the power station of the Detroit Edison Co., illustrating vertical steam turbine practice. (Figs. 115 and 116 are from West. Elec.).

turbines are of the vertical type, occupying a minimum of floor space. The most noticeable feature of such a plant is the disproportionate amount of space occupied by the boilers as



Westinghouse, Church, Kerr & Co.,
No. N. Y. 9827.
Engineers.

FIG. 116. Plan of the power station of the Detroit Edison Co.

compared with the engine equipment. This station as originally built was as shown in the illustrations, but it was afterward extended by the addition of a fifth unit.

Coal is handled automatically by the following mechanism. It is first dumped from the cars into an elevator located in a tower at a corner of the boiler room. The elevator discharges it at the top of the tower whence it falls through hoppers to a cable railway through a screen or direct. It is there delivered to bunkers over the boilers from which it is fed by spouts to automatic stokers. The boilers are of a water-tube type, of 520 horsepower each, and connected in batteries of six. Each boiler has 4834 square feet of heating and 2000 square feet of superheating surface. Each boiler battery delivers steam at 250° superheat, and 200 pounds pressure to a turbo-alternator unit of 3000-k. w. rated capacity.

The station is so large that all possible heat-saving devices are employed. The feed water for the boilers, pumped from the hot well, passes through open feed heaters, which are supplied with the exhaust steam from the auxiliary engines and pumps. It is heated thus to about 95° and at this temperature enters economizers through which pass the flue gases. Here the feed-water temperature is raised to 240° and the flue gases are reduced both in temperature and volume. The feed-water mains are in duplicate and each boiler has also an injector to supplement the pumps. From the boilers the steam from each battery passes to its turbine through 12-inch mains with cross-connections for emergency use. From the turbines the steam goes to surface condensers supplied with water by centrifugal pumps located in the adjacent pump house. The condensed steam and air are exhausted from the condensers by air pumps which deliver the water to the hot well, thus completing the steam circuit.

The alternators are 12-pole, 60-cycle, three-phase, 4600-volt



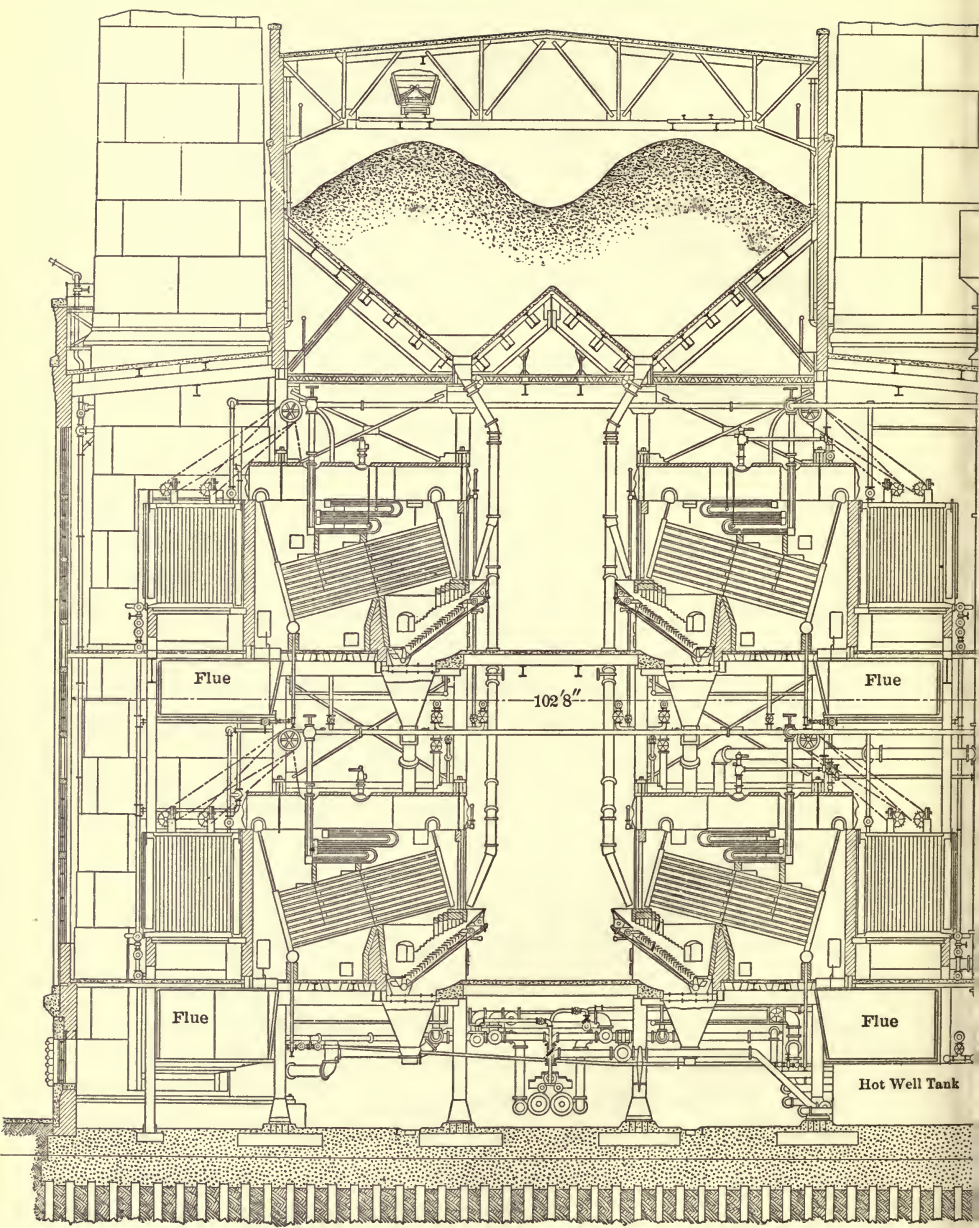

Westinghouse, Church, Kerr & C
 No. N. Y. 11938. Eng

FIG. 117. Section of the power plant of the Long Island R. R. Co., illustrating horizo

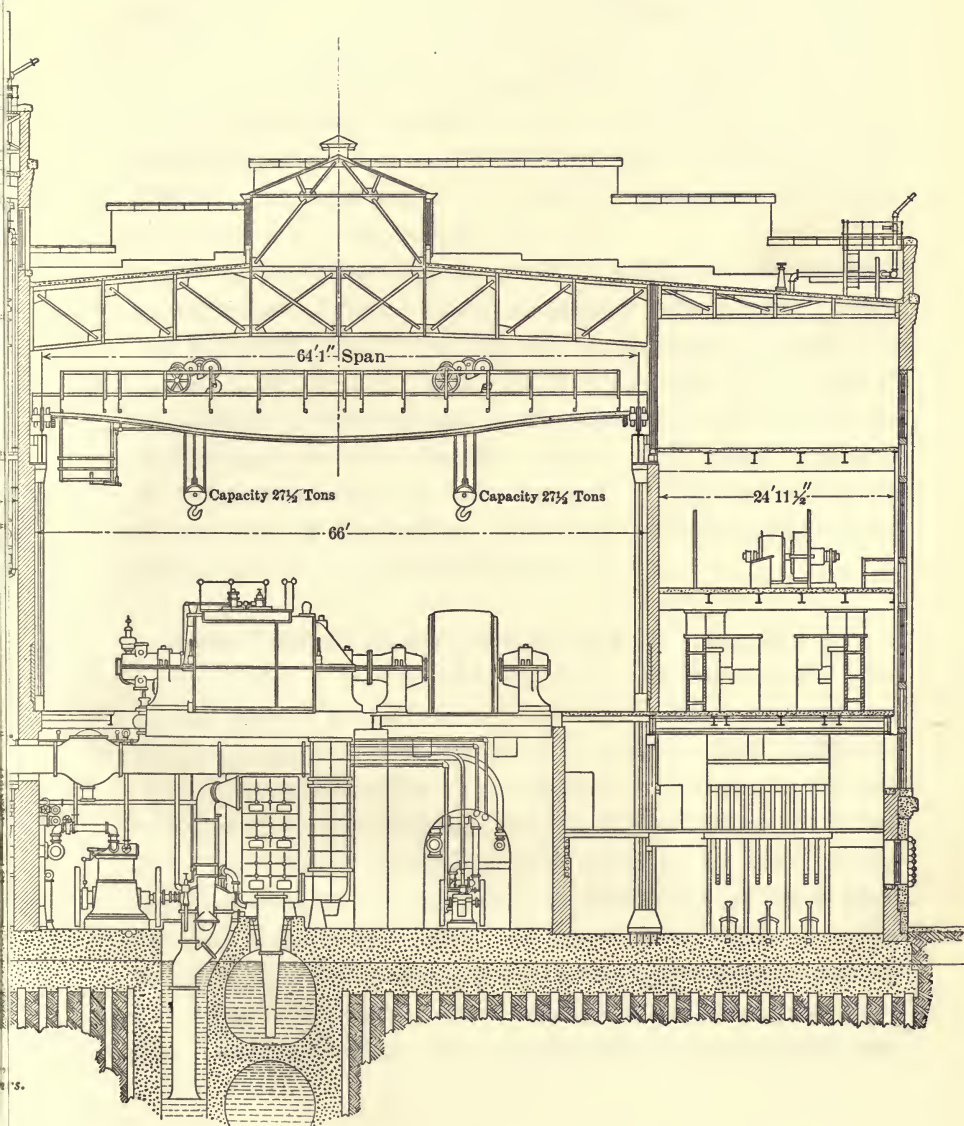

and steam turbine practice (this figure and Nos. 118 to 121 are from the St. Ry. Jour.).

machines and they operate at 600 r. p. m. They are furnished with field current by two exciters of 50-k. w. capacity each, direct connected to 75-horsepower three-phase induction motors. The exciters are supplemented by a storage battery of a capacity of 556 amperes discharge for one hour.

While this is primarily a lighting plant, a certain amount of power is furnished to the local railway company from a sub-station located in the turbine room. It contains a 1000-k. w. motor-generator set supplemented by a motor-generator booster set consisting of a 300-volt, 450-ampere generator driven by a 500 volt motor.

From the generators the current passes to oil-immersed generator and feeder switches controlled from a switch board and located in galleries at the side of the turbine room. The power is distributed to substations in which are located transformers, synchronous motor-generator sets, induction motor-generator sets, storage batteries and other apparatus to adapt the output to the demands of different localities. A large part of the lighting and motor service on the system is direct current and at different e.m. f.'s.

Steam Turbine Plants. *Horizontal Type.* A second typical turbine plant is illustrated in Fig. 117. In this case the horizontal type of turbine is used and some other features are radically different from those of the station just described. The fuel supply is taken from barges by a bucket hoist and elevated to a long bridge which connects the hoisting tower and the power station. Small cars are operated by cable on the bridge, delivering the coal into bins directly above the boilers. The latter are located upon two floors, one directly over the other, each containing eight batteries of two boilers each of the water-tube type. Each boiler has 5243 square feet of water heating surface with corresponding superheating area

of 1116 square feet. The fuel delivered by gravity through spouts, is fed on to the grates by automatic stokers and the ashes fall into hoppers below the fire pits from which they are loaded on small hand cars. The boilers deliver steam at 200 pounds pressure superheated 200°.

The feed water is drawn from hot wells (as this is a surface condensing system) and the waste is made up from the city supply mains. Feed water heaters are employed, practically as in the preceding case, and the general arrangement of condensers is similar.

The steam from each group of eight boilers is sufficient for one 5500-k. w. turbo-alternator. The generator end of each unit delivers three-phase current at 11,000 volts, 25 cycles, its full load rating being based on 289 amperes per terminal. The revolving field of the alternator has four poles punched from solid steel disks. The field windings are supplied with exciting current from any one of three sources of current:

- (a) Two steam driven, 200-volt, 200-k. w. turbo-generators.
- (b) One three-phase induction motor-generator set of 200-k. w. output.
- (c) A storage battery of 366 amperes capacity for one hour, supplemented by an induction motor-booster set of 12.5-k. w. output.

A diagram of the low tension wiring is given in Fig. 118. The alternator fields draw current from a pair of bus bars which are supplemented by an auxiliary pair. Each field switch is provided with a resistance through which the coils may be short-circuited to discharge the energy stored in their inductance and which might otherwise cause a destructive rise in e. m. f. The battery, engine-driven exciters, and motor-driven exciter feed into these bus bars.

The high-tension circuits are connected as in Fig. 119, the switching being done by oil-immersed circuit-breakers or

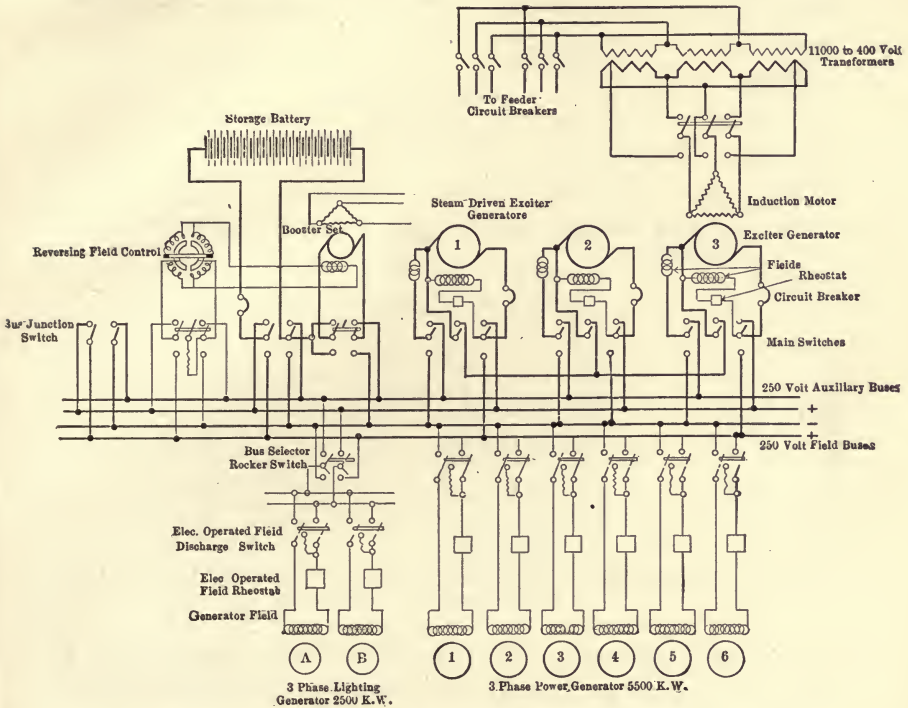

FIG. 118. Diagram of low tension wiring in the power plant of the Long Island R. R. Co.

switches. Fig. 120 indicates the general arrangement of the galleries in which the buses and circuit breakers are located, and from which the operation of the station is controlled.

A typical substation in this system is represented in elevation in Fig. 121. Its function is to transform the high-tension three-phase alternating current to low tension (550 volts) direct current for distribution to the electric railway system. The current enters at the right of the illustration and passes, first through choke coils and lightning arrestors mounted in

the gallery, thence through disconnecting switches, and circuit breakers to banks of 550-k. w. transformers containing three each. Each bank of transformers supplies one 1500-

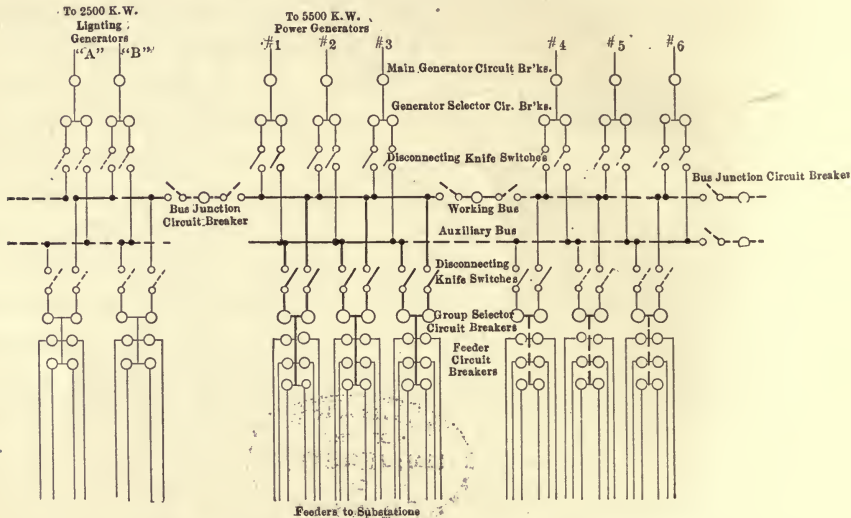

FIG. 119. Diagram of the high-tension wiring in the power plant of the Long Island R. R. Co.

k. w. rotary converter. The converters are brought to synchronous speed by induction motors direct connected to their shafts and used only for starting purposes.

From the d. c. ends of the converters the current passes through the measuring instruments and control switches to the underground conduits and thence to the line.

Hydro-Electric Plants. *Impulse Wheel Plant.* The power plant for which water is available is in every way simpler than one depending upon steam. The impulse wheel is the only one for very high heads and the turbine is in general use for low heads. Both are used for moderate heads, and they are in active competition on heads between 100 and 300 feet. The small impulse-wheel plant illustrated in Figs. 122, 123,



LIBRARY
OF THE
UNIVERSITY
OF
CALIFORNIA

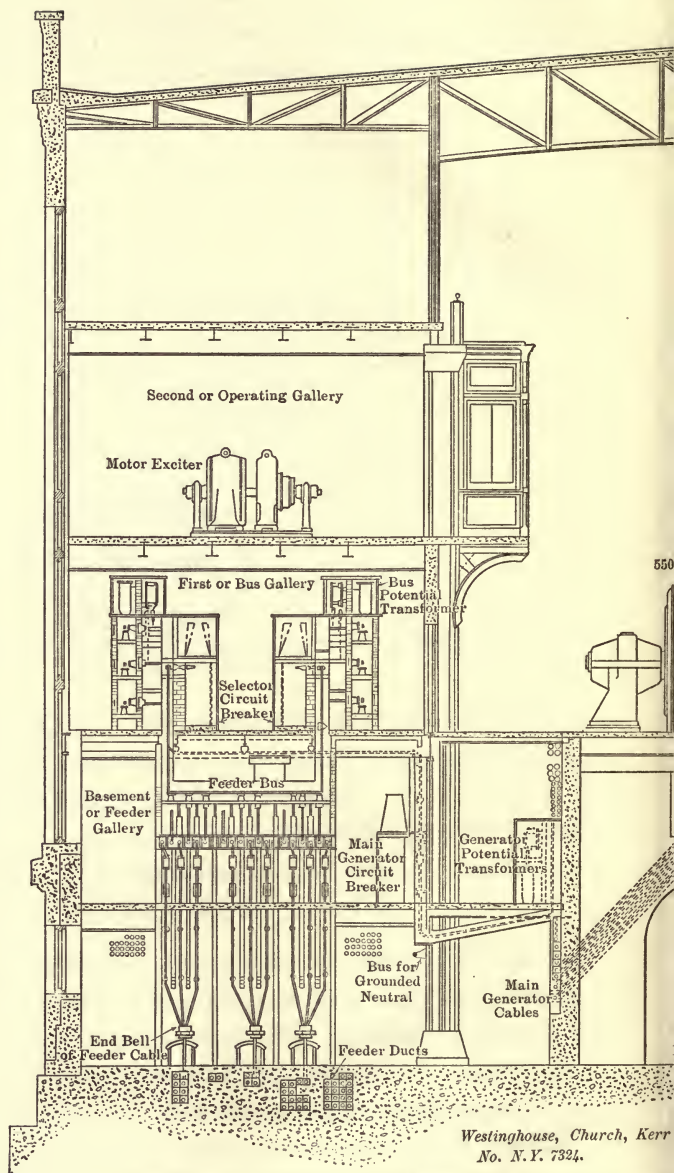
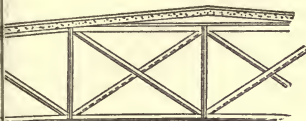
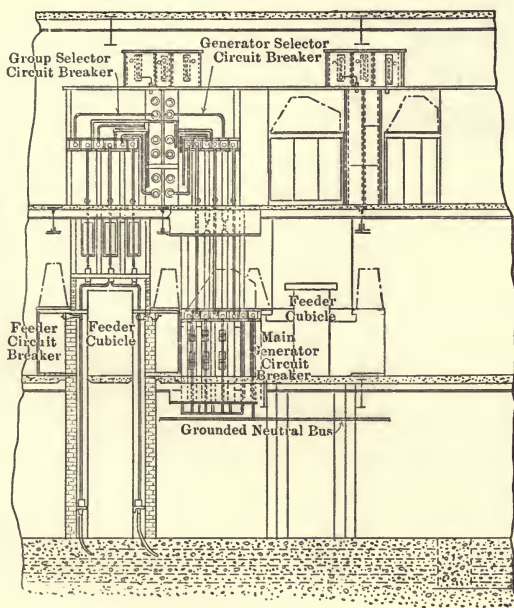

FIG. 120. Section of the elevated switch gallery



Generator



ent

engineers.

the power plant of the Long Island R. R. Co.





LIBRARY
OF THE
UNIVERSITY
OF
CALIFORNIA

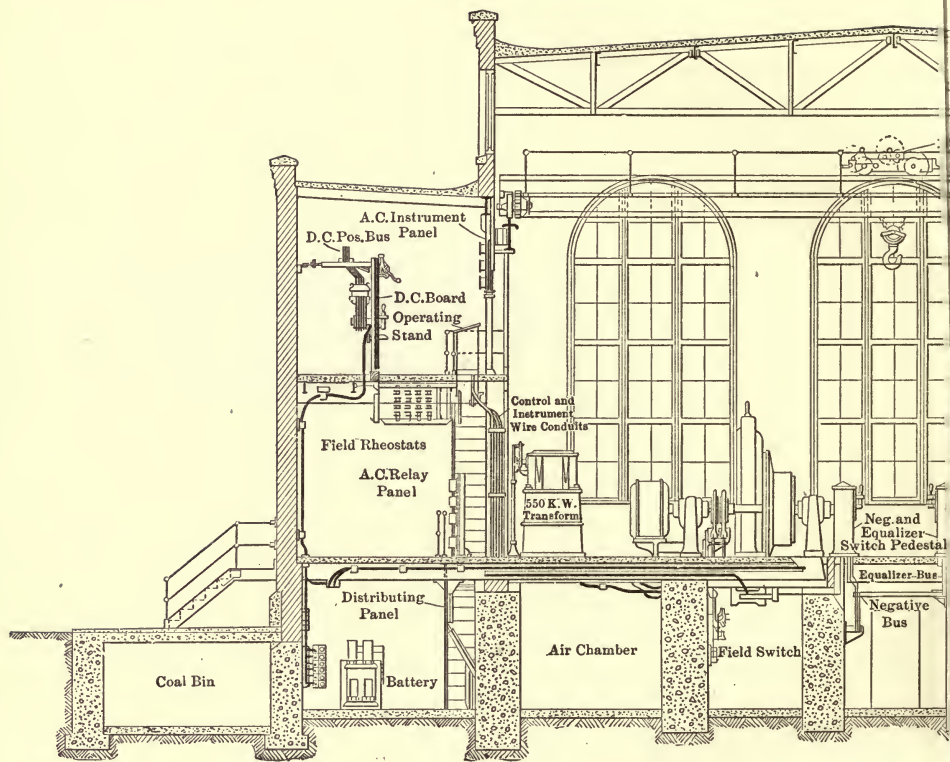

Westinghouse, Church, Kerr & Co.,
 No. N.Y. 14015. Engineers.

FIG. 121. Section of typical substation building.

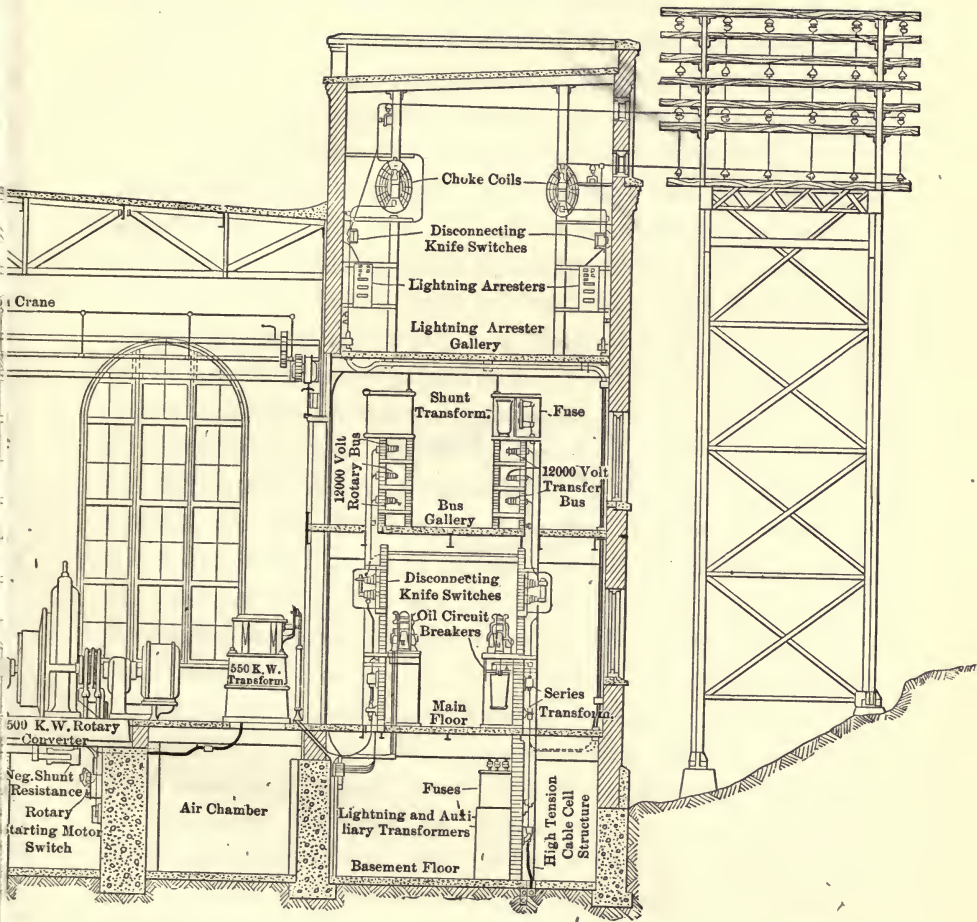

tion of the Long Island R. R. Co.



LIBRARY
OF THE
UNIVERSITY
OF
CALIFORNIA

and 124 has been selected as typical of its class. Water is secured from a creek with an average low water flow of 30 cubic feet per second, draining a water shed of 147.5 square miles. The head used is 145 feet, one which permits the use of either turbines or impulse wheels. The water is drawn from an impounding pond of 5,000,000 cubic feet capacity, formed by a concrete arch dam located at a narrow part of the gorge in which the stream flows. The hydraulic conduit line is of three kinds of construction; that nearest the dam being of re-enforced concrete pipe, the next of wood stave pipe, and the last being the steel penstock through which the main descent is made. The total length of conduit is 1766 feet and its internal diameter is five feet. A cistern and spillway is placed at the middle to avoid excessive strains at times of high water. This consists of an enlargement of the conduit with an overflow into the gorge. The lower end of the penstock is turned parallel to the length of the power house and is located on a concrete foundation below the floor level. In order to relieve the water pressure due to sudden changes in the load, a large air chamber is located near the lower end of the penstock. A motor compressor, operated occasionally, maintains a sufficient supply of air to act as a cushion to the water column.

The generating units have a normal output of 150 k. w. at a speed of 124 r. p. m. The impulse wheel consists of double brass buckets attached to the rim of a cast-iron disk 8 feet $6\frac{1}{2}$ inches in diameter. A nozzle with a 7-inch aperture delivers a stream of water against the middle rib of the buckets. The nozzle has in the center a needle-pointed core, which is moved back and forth by the governor, thus varying the supply of water to the jet. The generator of each unit is a 60-cycle, 2,200-volt three-phase alternator, with stationary armature and a 58-pole revolving field. Exciting current is furnished by two 30-k. w. d. c. 110-volt generators driven by small

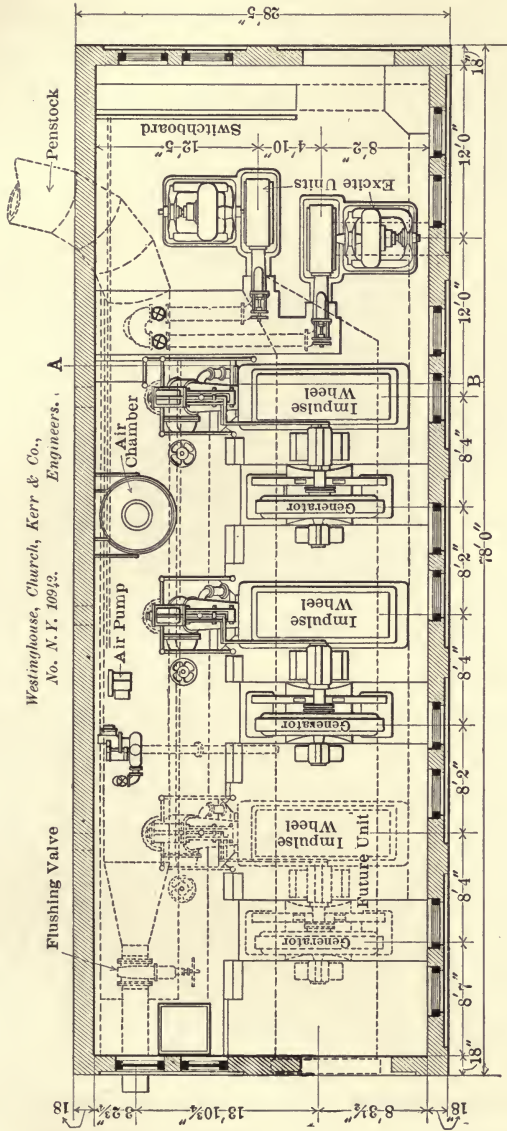

FIG. 123. Plan of the power plant of Cornell University illustrating impulse water wheel practice.

wheels of the same type as the large ones. The exciters furnish current for other purposes, such as projection lantern and storage battery service. At present a substation is located in the space assigned in Fig. 123 to a third unit and shown by dotted lines. A large amount of 500-volt d. c. power is demanded of the station and this requires the use of a 100-k. w., 500-volt,

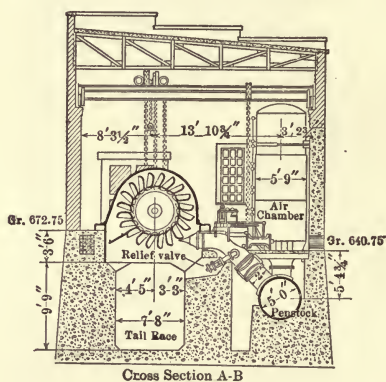

FIG. 124. Section of the power plant of Cornell University.

compound wound d. c. generator, direct driven by a three-phase, 2200-volt, 150-horsepower induction motor. Arc light service is given through a constant current transformer supplied with a constant potential of 2200 volts.

The switchboard in this plant has generator and feeder panels equipped with ammeters and wattmeters for the three phases, voltmeters, watt-hour meters, a power factor indicator, a frequency indicator and a synchroscope for synchronizing the generators. The power is distributed at generator e. m. f. as the area covered does not involve a transmission distance of over a mile.

Hydro-Electric Plants. Turbine Plants. Niagara Falls with an available head of 160 feet and an unlimited supply of water, is the center of turbine wheel development. Five large

plants, each with an ultimate output of over 100,000 horsepower are in operation, all using water wheels of the turbine type, either vertical or horizontal. One of these stations is shown in Figs. 125, 126, and 127. The plant comprises* thirteen 10,000 horsepower horizontal type turbines with

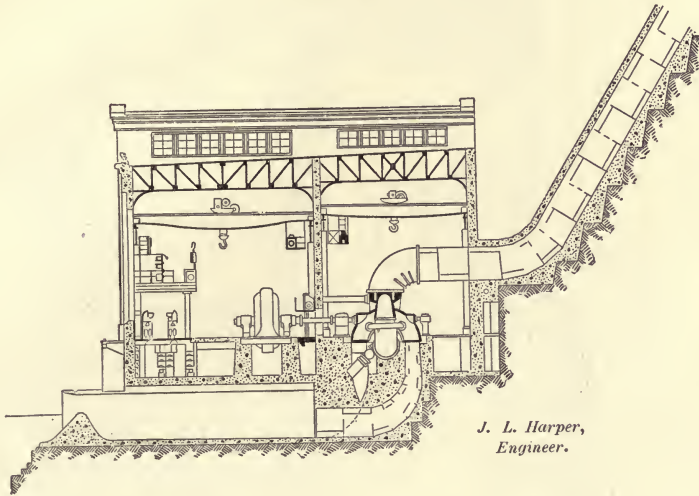

FIG. 125. Section of the power plant of the Niagara Falls Hyd. Power and Mfg. Co., illustrating water turbine practice.

inward discharge. Direct connected to the wheels are electric generators. Five wheels drive two d. c. generators each, the output being used for aluminum reduction. Six hundred and twenty-five volts are used and the current is transmitted a distance of 300 feet to the reduction works through aluminum bars of 140 square inches cross-section. The alternators are of 6500 k. w. each, delivering three-phase 25-cycle current at 12,000 volts at a speed of 300 r. p. m.

The power station is located at the bottom of the gorge below the falls. The building is 500 feet in length by 95 feet

* The description of the plant is as it will be when completed.

in width. It is divided longitudinally into two sections by a concrete partition, thus separating the turbines from the generators. The water for the plant is brought from above

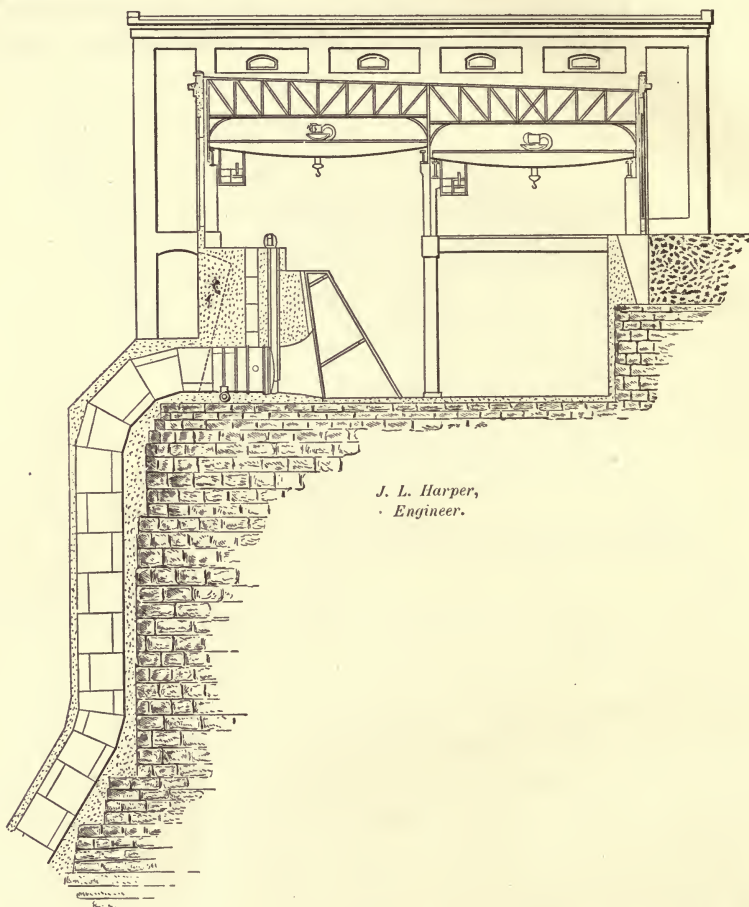

FIG. 126. Section of the head house of the power plant of the Niagara Falls Hyd. Power and Mfg. Co.

the falls through an open canal which terminates in a forebay at the edge of the cliff. The forebay is parallel with and directly above the station, and is approximately of the same

length. It is formed by a concrete wall, 30 feet high and 24 feet thick at the bottom, in which are imbedded the thirteen 9 feet steel penstocks. The flow of water into the penstocks is controlled by roller bearing gates, and racks and spillways are provided to prevent rubbish and ice from descending to the

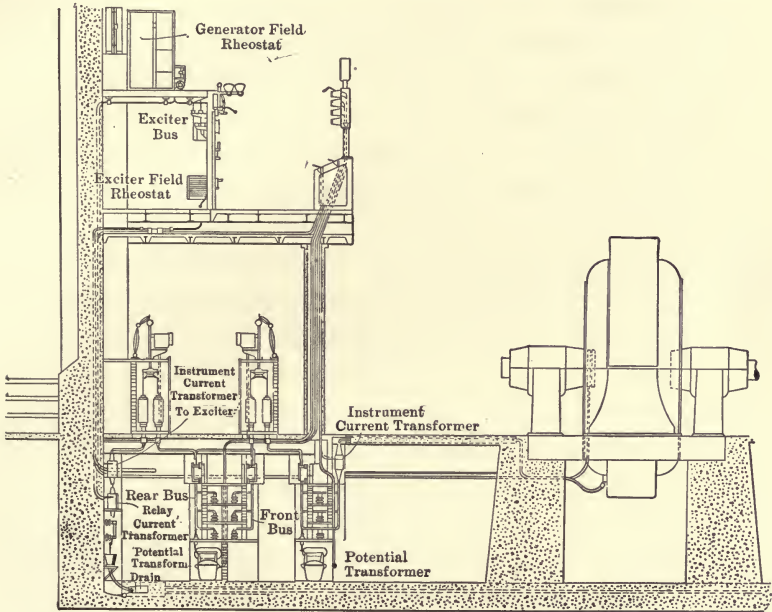

FIG. 127. Section of the switchboard in the power house of the Niagara Falls Hyd. Power and Mfg. Co.

wheels. The penstocks are supported by being encased in reinforced concrete which attaches them firmly to the steps cut into the solid rock of the gorge wall. As this method of support deprives the penstocks of all flexibility special devices are installed to relieve the wheel cases of excessive shock due to the operation of the governor and gates. These are bursting plates attached to the wheel cases and so designed that they will relieve the pressure on a slight increase above normal. The discharge from the turbines flows out through tunnels

located beneath the station floor and delivering the water into the gorge at the river level. At the exit it flows over a concrete dam, which improves the appearance of the streams and diminishes danger of erosion of the tunnel mouths.

The arrangement of the generator room is not unlike that of a steam station. The current passes through the conductors located in the basement to the high tension bus bars. Series transformers reduce the current and potential transformers the e. m. f. for measurement. The switch compartment contains the power-operated, oil-immersed circuit breakers, and above is the operating gallery with operating bench and instrument panels. As this plant is for local power supply, and will not be used on long distance lines, no provision has been made for elaborate lightning protection, a matter of the greatest importance in stations serving on extended territory.

Gas Engine Plants.

The high thermo-dynamic efficiency of the gas engine has forced it upon the attention of engineers for power plant purposes, and in spite of the complication of the engine itself, and especially that of the auxiliary apparatus, its use is increasing. Several large plants and numerous small ones have been installed within a few years and their efficiency is considered satisfactory. A typical small plant is given in plan in Fig. 128. As this plant burns bituminous slack it represents the most difficult conditions, and hence contains as elaborate an equipment as will be ordinarily found in such stations.

The Gas Producer is built of two concentric steel shells. The inner is the fuel chamber into which the slack is fed from an overhead hopper through an inverted bell located in the upper part of the chamber. The space between the inner and outer shells is for the passage of the entering air which is there superheated before entering the fuel chamber. In

following the air and gas through the various parts of the equipment it is convenient to begin at the *blower*, which delivers the air to the *air tower*, where it is saturated with water previously heated in the gas tower. The air tower contains numer-

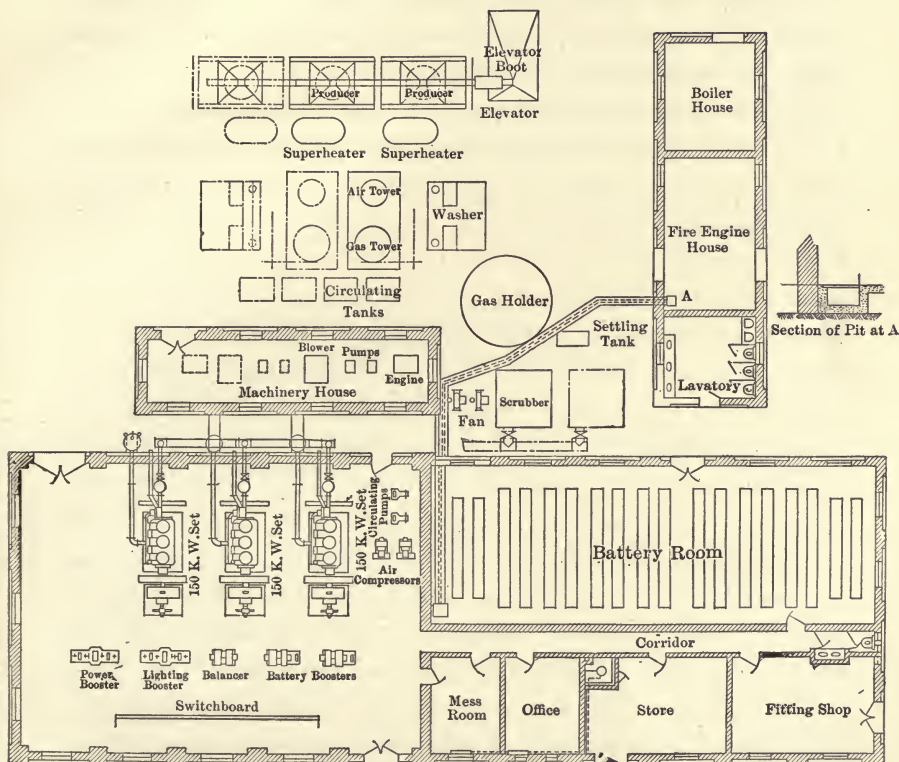

FIG.128. Plan of a typical gas engine power plant. (From *Elec. World*.)

ous tiles over which the water trickles and upward through which the air finds its way. From the tower the air passes through the *air main* where a further addition of moisture is received from exhaust steam which is discharged into it. Next the air reaches the *superheater*, of concentric shells, and circulates between the inner and outer tubes, the hot gas

being inside. Finally the air reaches the *producer*, first flowing through the annular chamber surrounding the fuel chamber, then into the latter through the *fuel bed*, which it reaches in a highly superheated and moist condition.

The gas, after leaving the producer, goes through the *superheater* above referred to, here losing some heat to the circulating air and leaving considerable dust. In the *gas-collecting main* through which it passes to the *washer*, more dust is left. The washer is a box containing revolving blades which whip the gas and spray it with water thus removing dust and tar and incidentally cooling it. The *gas-cooling tower*, next in the circuit, is similar in construction to the air tower, the same water trickling down over tiles and receiving heat which is afterward delivered to the air in the air tower. The gas is now ready for the *holder* in which it is stored and which automatically by its position controls the rate at which the gas is generated. When required for the engines the gas is drawn from the holder by a *fan* which by centrifugal action throws out tar from the gas at the same time cooling it by means of water fed into the fan case. The last step in the cleansing process is taken in the *scrubber* filled with saw-dust and shavings to remove the last vestige of tar. The clean, cool gas then enters the engines through pressure regulators.

The station contains three 3-cylinder single-acting engines, each direct connected to a 150-k. w. d. c. generator with a rated output of 325 amperes at 460 volts. A storage battery auxiliary contains 230 cells, with a capacity of 180 amperes for six hours. The charge and discharge of the battery are controlled by "boosters" located in the engine room and driven by auxiliary motors. As the output of the station is delivered on the three-wire system a "balancer" is employed to maintain an equal division of e. m. f. between the two branches of the circuit. Motor-driven boosters are also con-

nected in the power and lighting circuits to raise the e. m. f. to the desired values.

The switch-board contains numerous panels to accommodate the large number of pieces of special apparatus. There are positive and negative generator feeder and battery panels; booster panels and a neutral or middle wire panel. The use of boosters on the feeder lines is not general in the United States and this feature of the plant described should not be taken as representative of American practice.

The Storage Battery. Storage batteries are installed in power stations and substations for one or more of the following purposes.

- (a) To straighten the load curve.
- (b) To keep up voltage on heavy load.
- (c) To carry entire load at times.
- (d) To improve engine and generator operation.
- (e) To regulate voltage fluctuations due to variation in engine speed.
- (f) To supplement substation equipment.
- (g) For transformation and sub-division of voltage.

The chemical storage of energy is possible by producing cumulative changes in an electrolyte, in electrodes, or in both, by means of an electric current. This stored energy may be reclaimed by connecting the electrodes through an electric circuit. Various substances have been proposed as electrodes and as electrolytes, the cells in most general use having lead electrodes and sulphuric acid electrolyte. When charged, the positive "active material" is lead peroxide and the negative, spongy lead. The Edison cell consists of nickel and iron electrodes and caustic potash electrolyte.

Storage cells give practically a constant e. m. f. (two volts in the lead cell) the regulation varying with the current drawn

and the charge remaining. Capacities are rated in discharge ampere-hours and these vary greatly with the rates of charge and discharge.

The Lead Cell is the type used in power station work. The plates consist of grids or frames of antimonious lead (the antimony being added to give the lead the requisite mechanical strength). The grids act as the supports for the "active material," and at the same time conduct the current and distribute it uniformly over the plates. In one form of plate,

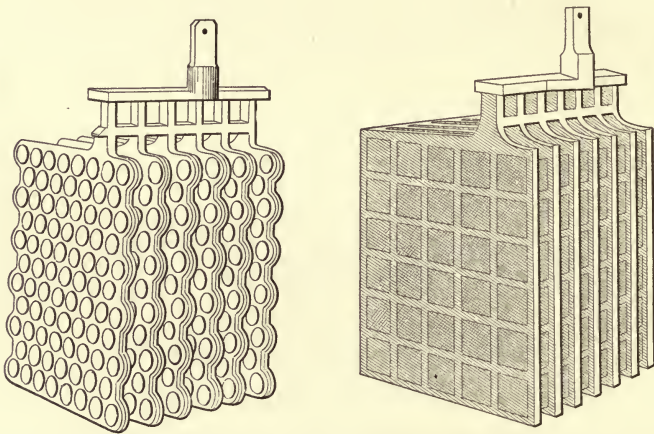

FIG. 129. Positive and negative sets of plates of a typical storage battery. (See also Fig. 19.)

the surface is deeply grooved and the active material is "formed" on the sides of the grooves by electrolysis.

Fig. 129 shows two sets of plates, negative and positive, of a type used in many power stations. The positive grid has round holes countersunk on both sides and filled with spirally-wound rosettes of lead tape pressed firmly into place. The rosettes are "formed," that is changed to lead peroxide, by means of the passage of current in a "forming" bath. The openings in the negative grid are filled with fused chloride

of lead, containing a small quantity of zinc, the whole cell being known as the "chloride" cell from the form in which the active negative lead is applied. The "forming" process for the negative plates consists in short circuiting them with zinc plates in a solution of zinc chloride which reduces the chloride in the "pastilles" to spongy lead. After forming, the plates are washed in water and in hydrogen.

The above statements indicate that after profiting by the improvements made upon Planté's invention by Faure, practice has again taken up the Planté process for the production of the positive plates. In Planté's time the formation of peroxide of lead upon the positive plates was a tedious process as it was done entirely by the action of the current in a sulphuric acid solution. Faure's method of "pasting" the plates with various oxides of lead was followed for many years. The later processes, returning in part to the Planté plate, but hastening the formation of oxide by the addition of oxidizing agents, have superceded that of Faure.

The plates of small cells are suspended in glass jars and those of large cells in lead-lined wood tanks. The electrolyte is a solution of sulphuric acid of a specific gravity slightly under 1.2. When the cell is full the positive active material is lead peroxide, PbO_2 and the negative active material is spongy lead. As discharge proceeds the positive material reduces to PbO , and the negative oxidizes also to PbO , both oxides absorbing SO_3 from the solution and forming lead sulphate, $PbSO_4$. Charging a cell results in increasing the sulphuric acid in the solution, the quantity set free depending upon the relative amounts of electrolyte and active material.

Capacity of Storage Batteries. The amount of energy which can be stored in a battery depends not only upon the quantity of active material but also upon the rate at which the

energy is supplied. Similarly the quantity which can be drawn from a fully charged battery varies greatly with the rate of discharge. For power purposes it is customary to rate a battery on a one-hour discharge. The same battery will have nearly twice this capacity if discharged in five hours. The capacity will be correspondingly less at a half-hour rate.

Battery Boosters and Regulators. The e. m. f. of charge and discharge differs by a considerable percentage amounting to as much as fifteen per cent in extreme cases. For this reason a battery "floating" upon a line, that is connected directly across it, will not act automatically unless the very large variation in e. m. f. is permissible, which is not usually the case. The simplest method of forcing the battery to charge or discharge is to vary the number of cells in circuit thus changing the battery e. m. f. with respect to the line e. m. f. The terminals of a number of "end" cells are connected to a sliding contact device by which the cells may be cut in or out either by hand or automatically. A better method of regulation is that involving the use of "booster," a generator of small e. m. f. but large current capacity, connected in series with the battery. The booster is usually direct driven by a motor. The booster e. m. f. is varied by the line current or the battery current which flows through a series coil on the booster field. When the battery e. m. f. is increased by the booster a discharge occurs and *vice versa*. The shunt field of the booster permits hand adjustment of the *average* rate of charge and discharge. As the efficiency of the battery is not high there must be a net over-charge of say 20 per cent.

An important adjunct to the booster is the "regulator" by the use of which the bulky series coil may be dispensed with.

The regulator has two essential parts:

(a) The carbon resistance, composed of piles of carbon disks, the pressure upon which may be varied.

(b) The pressure-producing coil and plunger. The coil carries the line current and produces a pressure upon the piles of disks through a lever mechanism.

Piles of carbon disks are sensitive to changes in pressure, the contact resistance being varied thereby. The resistances in the regulator are connected in the booster field circuit by a "wheatstone-bridge" arrangement so that the field current is varied with the load. The field circuit takes the place of the galvanometer in the Wheatstone bridge and the current flows through it in one direction or another in accordance with the relative values of the resistances in the bridge arms. These may be adjusted to produce automatically any desired performance of the battery.

Accumulator Handling. *For Economy.* Changing energy from the electrical to the chemical form and back again involves a considerable waste of energy, partly in the electrical resistance, partly in the chemical reactions. In order that a battery may not introduce losses which will counterbalance the saving which it is expected to make, it must be operated at maximum efficiency. The efficiency of the cell varies with the quantity of charge in it, being greatest when it is approximately one-half fully charged. Therefore, when a battery is installed for the purpose of improving the regulation of the load upon the generators, engines, and boilers and thus increasing their efficiency it should not be allowed to over-charge or to over-discharge.

A battery can be handled more easily for economy in the case described than when it is installed as a protection against the effect of break-down of other apparatus. In anticipation

of an emergency, such as a high "peak" in the load curve, or the possibility of a "shut down," the operator will naturally over-charge his battery to assure himself that it contains the maximum possible quantity of energy. Over-charging involves a waste of energy and hence does not conduce to economy. In most stations the battery combines the two duties, regulation and preparation for emergency, hence the rate and duration of charge and discharge are adjusted to produce the best average results under practical operating conditions.

Depreciation. The storage battery is an expensive component of a power station not only in first cost but especially in repairs and maintenance. Even when the cells are carefully manipulated the plates disintegrate. Great damage may be caused by allowing over-discharge, which results in injurious sulphating of the active material. This insoluble sulphate increases the resistance of the cell and reduces its capacity. The best indication of the charge in a cell at any time is given by a hydrometer which shows the proportion of sulphuric acid in solution. An occasional over-charge does no harm and it enables the operator to more readily estimate the charge in the battery as he knows that at the time of over-charge the battery was full. Battery plates are subject to warping or "buckling" which is caused by irregularity of electrolytic action in different parts of the same plate. The active material expands and contracts and in so doing produces mechanical strains. If these are not uniformly distributed the plate bends. When plates are in good condition the current distributes uniformly but if a short-circuit occurs, through loosening of the active material or other cause, the electrolytic action is localized and unequal strains result. Hence, the necessity for constant inspection of the spaces between the plates.

Operation of Power Stations.

Function of the Power Station.

The purpose of a power station is to produce electrical energy at a minimum cost per kilowatt hour under certain restrictions as to regulation of e. m. f. The cost of generating a unit of energy is determined from the operating expenses and the fixed charges. The former includes fuel, wages, salaries, and supplies. The latter covers depreciation on plant and interest on investment.

Power Station Characteristics.

Viewed as a whole the power station is an assemblage of machines and auxiliaries with certain combined characteristics. To obtain maximum efficiency from it requires that it as a whole be operated under the best conditions. Unfortunately a power station has imposed upon it a variable load, over the fluctuations of which it has no control. The efficiency with which the output is generated depends therefore upon the degree to which the machines are adjusted to fit the load.

The Load Curve. A diagram plotted between the output of a power station in amperes, or kilowatts, and the time of day is termed the *load curve*. Each kind of load has its characteristic curve consisting of "peaks," between which are depressions. The ideal load curve would be a straight line parallel to the axis and the nearer the actual line approaches this the more economically can the station be operated. A station supplying current for electro-chemical purposes has nearly an ideal load as the operation is practically continuous. Such loads, however, are exceptional. The ratio of the average load during the 24 hours to the maximum load is given the name *load factor*, which varies from nearly 100 per cent in a very few cases to as low as 25 per cent in many stations. The

effort is always made to so modify the load curve as to raise the load factor. In Fig. 130, which represents a *lighting load curve*, the factor has a good value.

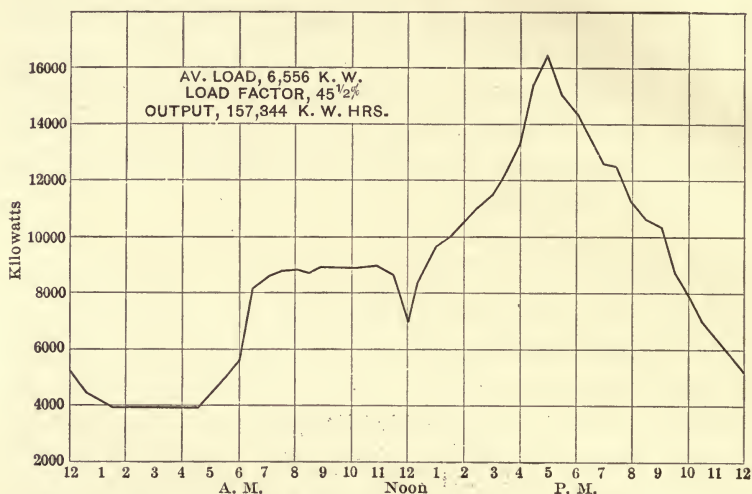

FIG. 130. Typical load curve of the power station of the Detroit Edison Co.

Fig. 130 has been selected as a characteristic lighting curve in a large station. It shows two characteristic peaks, the main one naturally occurring in the evening. Between the peak hours there are certain parts of the day during which very little light is used, but the power load which always accompanies a lighting load tends to fill up the depressions.

The Railway Load Curve. The railway load curve is a less satisfactory one than the lighting load curve for the reason that its fluctuations are more rapid and of a greater magnitude than in the preceding case. Fig. 131 represents the operation of a large railway power station. The peaks are located at different parts of the day and the maximum load is much greater in proportion to the average. A railway load is the most difficult which a power station can be called upon



LIBRARY
OF THE
UNIVERSITY
OF
CALIFORNIA

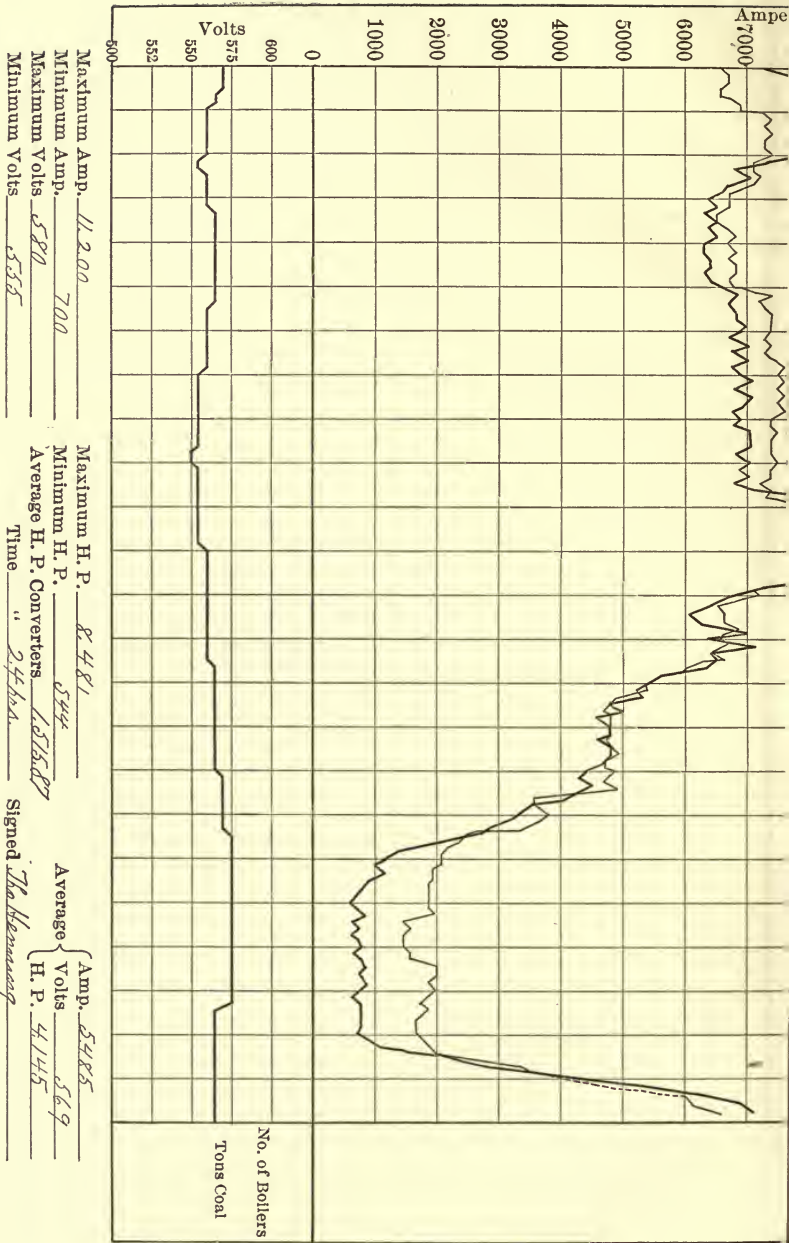

FIG. 131. Typical curve of the power station of the Buffalo Ry. Co.

to supply on account of this variable nature. The variations are of three kinds:

(a) Very rapid fluctuations due to the starting and stopping of the individual cars.

(b) Variations due to accidental increases and decreases of average load and usually extending over several hours.

(c) Peaks and depressions, caused by the natural variations in traffic, due to business and other conditions. For example, a road which connects the residence with the business district will carry passengers from their homes to their places of business in the morning and return them in the evening. During the day the various members of the households will go down town for shopping and other purposes, probably returning at about the close of the business hours. The morning load will, therefore, be somewhat spread out, while the evening load will be concentrated with a very high peak.

The Effect of the Storage Battery. On account of the fluctuations in the load exhibited in the load curves the storage reservoir for energy is obviously very desirable. The storage battery is at present the one available energy reservoir. Other energy storage devices have been proposed, for example, the hot water heat storage, but these have not proved economically satisfactory. In spite of its imperfections the storage battery serves several essential purposes as already outlined. Fig. 132 indicates what can be done in a small railway plant by the addition of a storage battery of suitable capacity. The figure shows the load upon the station and the current drawn from the generators. The latter is for all practical purposes constant, hence the generators operate at a high and uniform efficiency. The battery takes all of the fluctuations in load, and the generator capacity installed in this station is smaller than would be necessary if the storage

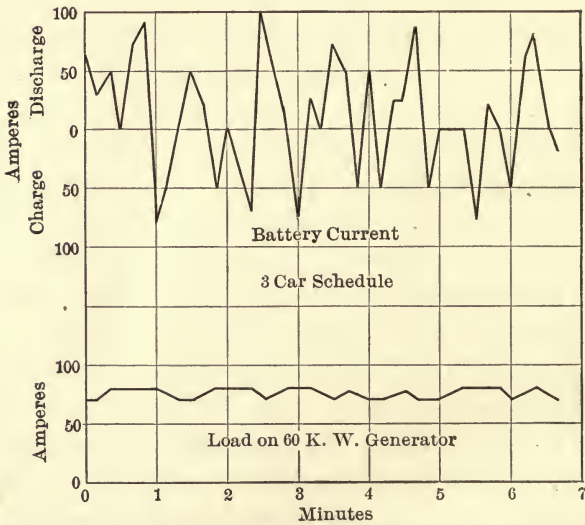
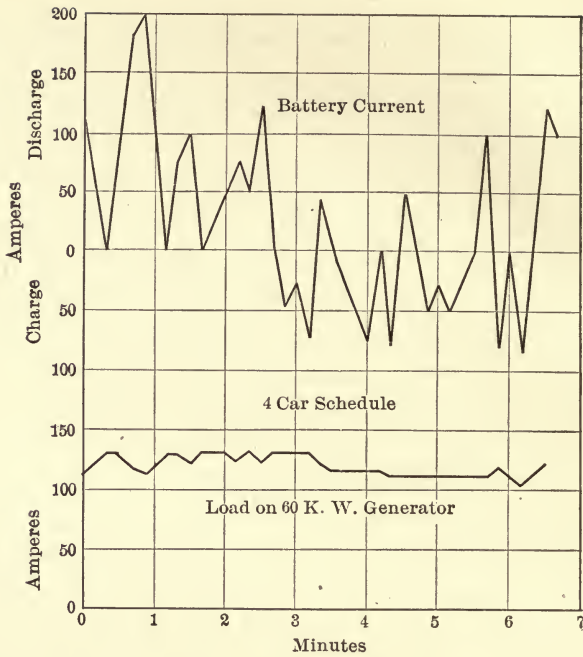

FIG. 132. Load curves of a railway power station with and without the storage battery.

battery were not used. Steady current is accompanied by good regulation of e. m. f. so that two important functions are performed by the battery at the same time.

Fig. 131 is taken from a station in which a very large battery is installed. The heavy line is the station load line and the light one the generator load line. The difference between these two lines is caused by the presence of the battery. When the light line is below the heavy one the battery is discharging and *vice versa*. The figure shows very clearly the effect of the battery in relieving the station equipment at times of peak load. The proper adjustment of prime mover capacity to the load is provided by shutting down or starting up the engines. The station is divided into such a number of units that the load will be properly provided for and at the same time the units in operation will be well loaded. A note has been made on the diagram each time an engine or other unit has been started or stopped. In a very large station like this one the principal function of the battery is to assist on peaks and to allow shut down at times of very light load. The load is so large that such minor matters as starting of cars produce no appreciable effect as in the small road from which Fig. 132 is taken. Hence, the saving in operation due to the use of the battery is not as marked, the actual saving being due rather to reduction of engine, generator, and boiler equipment. It is difficult to place a money value upon the assurance that power can be sent to the line even if the entire generator equipment is disabled for a short time. This is of extreme importance, however, particularly in large plants, and it is coming to be considered the best justification for the use of the expensive storage battery.

Power Station Economics.

Cost of Producing Electrical Energy. It is customary to divide the expense of power station operation into the two general parts:

- (a) Operating expenses.
- (b) Fixed charges.

Operating costs include all those expenses which are necessary in keeping the plant running, such as salaries, wages, fuel, lubricant, repairs, etc. The fixed charges, sometimes known as "over-head" charges, are the interest on money invested in the plant and the depreciation on the plant. The money which is invested in the plant would, if placed elsewhere, be earning a certain return, presumably 5 per cent. There must, therefore, be an income over and above the operating expenses sufficient to provide this amount of interest. In addition a certain amount must be allowed for the general deterioration of the equipment. This is independent of the repairs which are necessary to maintain the machinery in running condition but which do not make up for the "wear and tear" as a whole. New types of machines are being constantly developed so that a station must be rehabilitated occasionally, even if the machines are not worn out. This is the meaning of the allowance for deterioration.

Station Records. Bookkeeping in a power station has come to be of the greatest importance in order that the cost of producing energy may be accurately determined. Every well-managed station makes records of at least the following items. (The fuel and water items do not apply to water power plants.)

- (a) Total daily energy output.
- (b) Average daily power output.
- (c) Maximum daily power output.
- (d) Minimum daily power output.

- (e) Total daily water consumption.
- (f) Total daily water evaporated.
- (g) Total daily fuel consumption.
- (h) Periods during which various machines are in operation.

From this data may be deduced:

- (a) Pounds of coal per kilowatt hour generated.
- (b) Pounds of water evaporated per pound of coal.

The total daily energy output is determined by means of integrating watt-hour meters or by integration of the load curve plotted from frequent readings of indicating instruments.

The average daily power output will then be the total daily energy output divided by twenty-four hours. It may also be obtained by integrating the power load curve.

Maximum and minimum power outputs are determined from the load curve. The maximum output is necessary in order to calculate the load factor.

The water consumption is desired in order to obtain its cost where water is bought, and in condensing plants it is also an indication of the amount of leakage in the system. In non-condensing plants this information is directly useful in finding the evaporating efficiency of the boilers. In condensing plants it is necessary to measure the water actually flowing into the boilers, as only a small part comes from outside. Water meters are commonly used for this purpose.

Fuel consumption may be determined in a number of ways, the most convenient being to feed the boilers through measuring hoppers. In some plants the fuel is actually weighed.

The data mentioned are not sufficient to permit the calculation of the cost of generating a unit of energy, but they permit the comparison of the station with others of somewhat similar construction. The best basis of comparison, however, is that in which all items of cost are included as some

plants use a small amount of fuel and evaporate a pound of water with a very small quantity of coal, but this efficiency is counter-balanced by large deterioration and interest.

The following table by Mr. H. G. Stott* indicates a satisfactory sub-division. This table also contains useful data for comparison of the various items in stations employing different types of prime movers.

DISTRIBUTION OF MAINTENANCE AND OPERATION CHARGES.

	Reciprocating Engines.	Steam Turbines.	Reciprocating Engines and Steam Turbines.	Gas Engine Plant.	Gas Engines and Steam Turbines.
MAINTENANCE.					
1. Engine room mechanical	2.57	0.51	1.54	2.57	1.54
2. Boiler room or producer room	4.61	4.30	3.52	1.15	1.95
3. Coal and ash-handling apparatus	0.58	0.54	0.44	0.29	0.29
4. Electrical apparatus ...	1.12	1.12	1.12	1.12	1.12
OPERATION.					
5. Coal- and ash-handling labor	2.26	2.11	1.74	1.13	1.13
6. Removal of ashes.....	1.06	0.94	0.80	0.53	0.53
7. Dock rental	0.74	0.74	0.74	0.74	0.74
8. Boiler-room labor.....	7.15	6.68	5.46	1.79	3.03
9. Boiler-room oil, waste, etc.	0.17	0.17	0.17	0.17	0.17
10. Coal	61.30	57.30	46.87	26.31	25.77
11. Water	7.14	0.71	5.46	3.57	2.14
12. Engine-room mechanical labor:	6.71	1.35	4.03	6.71	4.03
13. Lubrication	1.77	0.35	1.01	1.77	1.06
14. Waste, etc.	0.30	0.30	0.30	0.30	0.30
15. Electrical labor	2.52	2.52	2.52	2.52	2.52
Relative cost of maintenance and operation	100.00	79.64	75.72	50.67	46.32
Relative investment in per cent	100.00	82.50	77.00	100.00	91.20

*Trans. A. I. E. E. Vol. xxv., p. 26.

Practice differs in regard to the sub-division of the items of station expense.

Effect of the Load Factor. In comparing the efficiency of various stations due allowance must be made for the effect of load factor. A low load factor involves high interest and depreciation, for sufficient equipment must be installed to meet the heaviest demands. This equipment stands idle for the greater part of the time and is the cause of disproportionately large fixed charges. A high-load factor results in efficient operation of the machines and in small fixed charges, and while the expense for maintenance and operation is large, this by no means offsets the saving. The great problem, therefore, in power station operation is to increase the load factor. Various expedients are in use, and these may be summarized under two general heads:

(a) The use of storage batteries for lowering the peaks and filling in the depressions of the load curve.

(b) The encouraging of the development of business which demands power at times of light loads, and the discouraging of that which increases the peaks.

The second method is receiving most careful attention. Customers are given preferential rates when their *maximum demands* are low as compared with their energy consumption. Customers are also encouraged to use power for other purposes than the one for which the station has been constructed. For example, the management of a lighting station by stimulating customers through attractive rates, to use current for power purposes at times of light load, may very greatly increase the load factor. In connection with some plants special industries have been established to consume power at times when the normal demand is light.

Charging for Electrical Energy. Modern systems of rates, based upon the maximum demand, are somewhat complicated, but when the purpose underlying the systems is understood the prices appear much more reasonable. This purpose, as previously stated, is to encourage the development of a high load factor in the station load. Small customers are usually charged a certain maximum rate per kilowatt-hour with a discount depending upon the monthly consumption. A minimum charge, usually one dollar per month, is made to cover interest on meter and service connections. The small customers (using from one to five dollars' worth of energy per month) do not greatly affect the load factor, and usually they have little control over the time at which they use power.

Customers using large quantities of energy are charged by one or another form of "load-factor system," the rates being determined by the maximum demand as well as by the actual energy consumed. An example of one such system is as follows: *

"The customer is charged a certain rate per kilowatt-hour, known as 'primary' rate, for a consumption of electricity equivalent to the use of his maximum demand for a certain number of hours per day or month, but should his consumption be greater than the above-mentioned amount, he is charged for all the excess at a lower 'secondary' rate. For example, the rate might be as follows: 15 cents per kilowatt-hour, as the primary rate, to be charged on a consumption equivalent to the use of the maximum demand for 30 hours per month, and for all consumption in excess a rate of 5 cents per kilowatt-hour to be charged. This system is very widely used and in fact is the form of load factor system employed in a great majority of cases."

* Quoted from paper by Mr. J. S. Codman, Proc. (not Transactions) A. I. E. E., April, 1907.

CHAPTER X.

ELECTRIC MOTORS AND THEIR APPLICATIONS.

OUTLINE.

GENERAL PRINCIPLES.

Construction and Underlying Principles of Electric Motors:

- Synchronous a. c. motors — Induction a. c. motors — Series motors
- Shunt and compound-wound d. c. motors — Series a. c. motors
- The Interpole motor.

Motor Characteristics:

- General Principles: Synchronous a. c. motors — Induction a. c. motors
- Series a. c. motors — Shunt and compound-wound d. c. motors —
- Series d. c. motors — The Interpole motor — Motor Handling and control.

GENERAL PRINCIPLES.

Starting:

- General Principles: Synchronous a. c. motor — Induction a. c. motors
- Series a. c. motors — Shunt and compound-wound d. c. motors —
- Series d. c. motors.

Speed Control:

- General Principles: Synchronous a. c. motors — Induction a. c. motors
- Series a. c. motors — Shunt and compound-wound d. c. motors —
- Series d. c. motors — Protection against over-load.

AN electric motor produces mechanical force or torque by the reaction of the current upon the magnetic field. Whenever a current exists in a conductor in the presence of a field a force is produced which is proportional to the strength of the field (in maxwells per unit area), the length of the conductor and the current. In c. g. s. units the force is the product of these quantities. *This is true regardless of the velocity of the conductor.* With the current and field in the same relative

directions the force will be in the same direction. A reversal either of the field or current will reverse the direction of the force.

There are many types of motors upon the market and at first the number appears bewildering. The underlying principles of all are the same and the different forms have been developed under the following conditions:

(a) in adapting the motor to the variety of supply, e. g., d. c., single-phase a. c. or polyphase a. c.;

(b) in adapting the motor to the kind of work to be done, e. g., propelling street cars, driving machine tools, etc.;

(c) in adapting the motor to the surroundings in which it is to operate, e. g., some motors must be placed in a limited space under cars, where moisture prevails, while others have ample space and good dry ventilation.

Practically any generator when supplied with the variety of current which it produces normally will operate satisfactorily as a motor. The requirements for good performance in the two cases are not necessarily the same, but as a rule an excellent generator is an equally good motor. All motors, however, cannot be used commercially as generators, for there are several motor types which are not the reverse of usual generator types. The following table illustrates the above statements:

<i>Type of Generator.</i>	<i>Corresponding Type of Motor.</i>
Synchronous alternator, single or polyphase.	Synchronous motor, single or polyphase.
Non-synchronous alternator, single or polyphase.	Induction motor.
Shunt d. c. generator.	Shunt d. c. motor.
Compound d. c. generator.	Compound d. c. motor.
Series d. c. generator (not largely used).	Series d. c. motor.

In addition there are several types of motor for which no corresponding generator is in commercial use.

Construction and Underlying Principles of Electric Motors.

Synchronous a. c. Motors.

Any single or polyphase alternator will operate as a motor when supplied with current at the same e. m. f., frequency and number of phases which it produces as a generator. As a rule such a motor is not self-starting. It is excited with direct current from a separate exciter and hence has poles of fixed polarity.

Suppose an alternator at rest and that its armature be connected to a circuit of proper e. m. f. and frequency. Current will flow through the armature windings and will produce an alternating reaction upon the separately excited field. The alternating torque will be absorbed by the inertia of the rotating member (armature or field magnet) and no rotation will be produced.

If the rotating member be first brought to the speed at which the line frequency is generated by the armature (*synchronous speed*) and then the armature be connected to the line, the rotating member will continue at synchronous speed.

It will also produce torque for driving a load. It does this because at synchronous speed the field flux and the armature current are always in the same relative direction. That is, by the time that the current in an armature conductor has reversed its direction it finds itself in a field of opposite polarity to that in which it was located a quarter period before. Hence it is necessary to bring the rotating part to exactly synchronous speed before the motor will fall "into step."

Starting a synchronous motor is exactly the same process as "synchronizing" an alternator and the same arrangement of lamps is suitable to indicate the attainment of synchronous

speed.* After the motor has been synchronized it will remain in step until over-loaded to such an extent that the torque produced is not sufficient to overcome the resistance of the load, when it will instantly stop or "break down." The over-load which a motor will carry before breaking down varies with the design, but usually it may be expected to withstand two or more times the rated load, the latter being based upon the allowable rise of temperature.

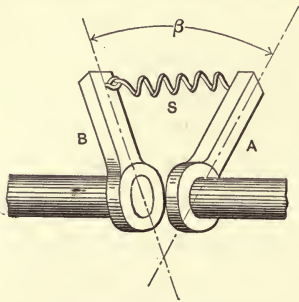

FIG. 133. Transmission dynamometer illustrating the principle of the synchronous motor.

The performance of the synchronous motor may be illustrated by the simple mechanism shown in Fig. 133. Power is being transmitted between two rotating cranks, *A* and *B*, through a connecting spring *S*. Such transmission is only possible when the two cranks are rotating at synchronous speed. When so rotating, the spring will be stretched so that the cranks are displaced an angle β (measured in a plane normal to the axis of the shafts). If *A* is driving and *B* driven, an increased load may be placed upon *B* until the spring is stretched to that point at which maximum turning moment is produced. After this point is passed the driven shaft will stop, and the driver will produce alternate jerks upon the driven crank through the spring. Obviously the break-down point will depend upon the strength of the spring and upon the distances of attachment points from the axis.

* Polyphase synchronous motors may be started by connecting to the line through lowering transformers and with the field circuit open. The mechanical reaction of the armature current upon the eddy currents generated in the field poles produces a small rotative effort sufficient to bring the moving member to synchronous speed without load. The principle underlying this performance will be understood after a study of the induction motor.

Induction (asynchronous) a. c. Motors.

The induction motor is a logical development of the experiment of Arago which so interested Faraday while an assistant in Davy's laboratory and which led him to the discovery of the laws of electro-magnetic induction. Arago *rotated* a magnet before a metal disk and noticed that the latter had a tendency to follow the motion of the magnet. The magnetic field, cutting the disk, produced e. m. f. and eddy currents therein and the latter reacted upon the field. This was the original *rotating field*. More than fifty years later

Ferraris discovered that a rotating field may be produced from stationary coils by means of polyphase alternating currents. Fig. 134 illustrates the principle discovered by Ferraris and commercially applied by Tesla, Dobrowolsky and Brown. Two circular coils are placed together with vertical diameters coinciding and planes at right angles. Inside is a pivoted metal sphere.

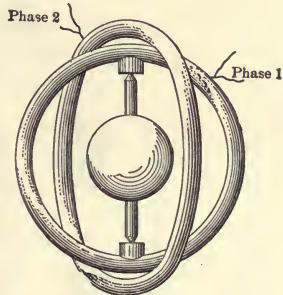

FIG. 134. Apparatus to illustrate the principle of the induction motor.

The coils are supplied with two or quarter-phase currents (two currents in quadrature). The sphere revolves because a rotating field is produced within the coils. This results from the following facts. The current in phase 1 is maximum when that in phase 2 is zero. At this instant the magnetic axis is perpendicular to coil 1. A quarter cycle later the current is maximum in coil 2 and zero in coil 1. The former therefore produces the flux which has shifted its position in space by 90° , cutting the sphere in so doing. Each cycle of current corresponds to a complete revolution of the magnetic axis which therefore rotates at synchronous speed. At instants intermediate between those mentioned the flux is

produced by the two coils jointly. It occupies a position depending upon the relative currents in the two coils. While the field rotates at synchronous speed the sphere follows at a slower speed, for if it revolved as rapidly as the field it would not be cut by the flux, no eddy currents would be generated and there would be no source of torque. The sphere "slips"

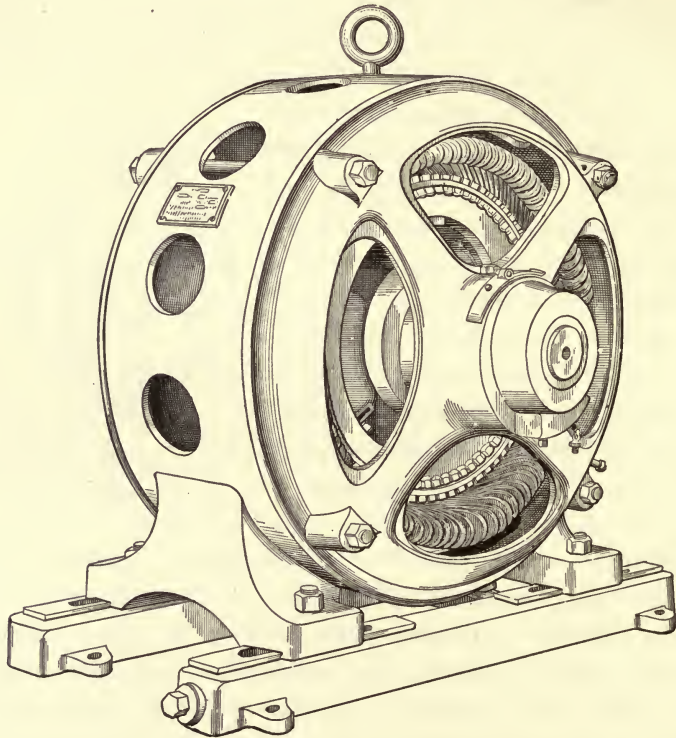

FIG. 135. View of a. c. induction motor (Allis-Chalmers Co.).

behind the field by the amount necessary to cause sufficient eddy current to produce the required torque. The *slip* is a certain per cent of synchronism.

The induction motor illustrated in Figs. 135, 136, 137, and 138 operates upon the same principle as the rotating sphere.

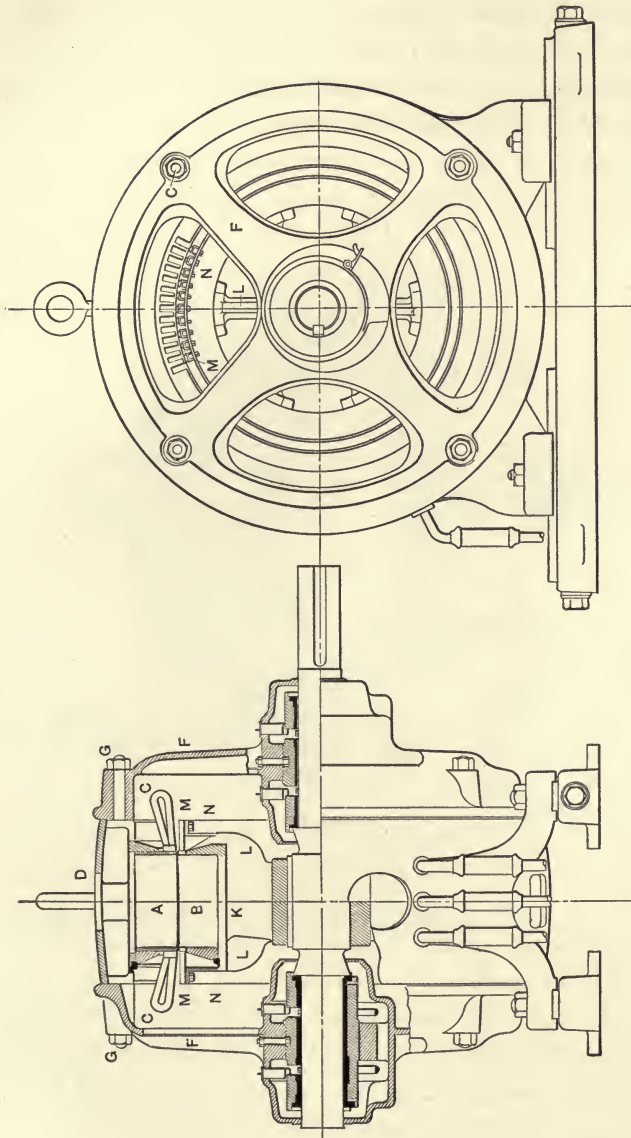

FIG. 136. Elevation and section of a. c. induction motor (Allis-Chalmers Co.).

The *primary* circuit connected to the line corresponds to the two coils. It may revolve or it may remain stationary as may the coils in the Ferraris model if the sphere be held at rest. Fig. 137 shows the primary winding with its core and support. The coils and connections are the same as in the

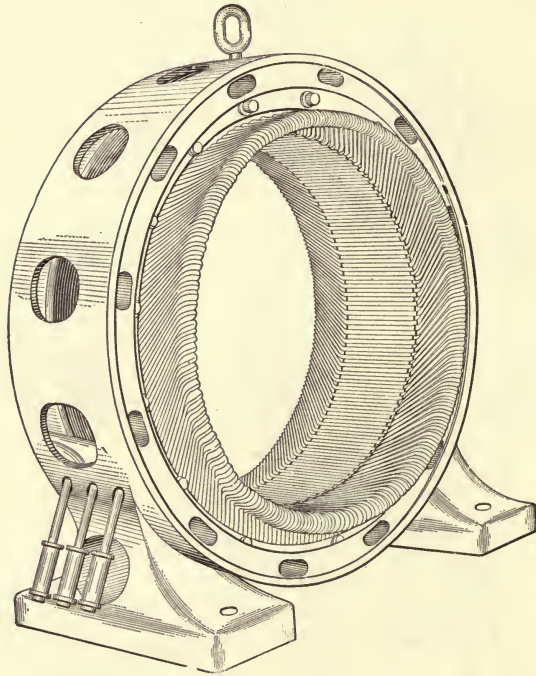

FIG. 137. Primary core and windings of a. c. induction motor.

armature of an alternator and the diagrams of alternator windings are applicable here. The form of coil and the plan of winding shown in Figs. 61 and 63 are preferred for motor construction. The *secondary* circuit corresponding to the metal sphere is made of copper bars, mounted in slots upon

a laminated core, and all short-circuited by rings at the ends. The secondary is made in this form in order to confine the currents to the paths in which they will produce the greatest torque and the least heat, the metal sphere being inefficient in these particulars.* Such an arrangement is known as a "squirrel cage" secondary and most induction motors built in this country are of this type. It is sometimes desir-

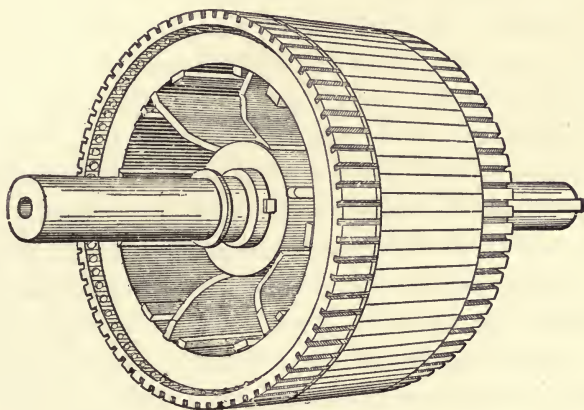

FIG. 138. Secondary core and conductors of a. c. induction motor.

able to replace the bars with a winding similar to that upon the primary core. In distinction to the squirrel cage, this is known as a "phase-wound" secondary.

It is evident from the statements made above that if the field magnet of any alternator be removed and a squirrel cage or phase-wound secondary replace it, an induction motor will result. Further, when supplied with the variety of current normally furnished by the winding when used as an

* It is for a similar reason that the disk of the modified Faraday apparatus shown in Fig. 20 is slotted radially.

armature, a rotating field is produced which will drive a short circuited secondary at a speed somewhat below synchronism. As it is not necessary to have any motion of the secondary in order to produce torque, a polyphase induction motor is self-starting, an obvious advantage over the synchronous type.* The principle of the polyphase induction motor also applies to the single-phase motor, but the latter is not as efficient nor as satisfactory. If all but one of the primary circuits of a polyphase motor be opened after it has been brought to speed, it will continue to revolve at a slightly reduced speed. It does so because the combination of the primary and secondary takes the place of the missing primary circuits. Such a motor will not start from rest with but one phase in operation, but if started even at a very low speed it will tend to accelerate and if not heavily loaded will "pick-up" rapidly. Motors of the single-phase induction type are in general use on small fans, in sewing machine outfits and for other purposes demanding power in small units, and they are very satisfactory. To obviate the necessity of hand starting, small copper links (shading coils) are placed on the sides of the coils, and these produce m. m. f. somewhat out of phase with the main coils and yield a feeble but sufficient starting torque.

Series a. c. Motors.

A motor consisting of armature, commutator, and field magnet, and with armature and field connected in series, will produce torque in one direction when supplied with alternating current. As the same current passes through armature and field the current in the armature conductors and the flux re-

* The reason for the self-starting possibilities of polyphase synchronous motors is now evident. As the armature produces a rotating field this cuts the poles and generates eddy currents therein. A weak torque is produced and the rotating part is brought to speed. The field circuit is open during this operation.

verse at the same time and produce torque. To produce a satisfactory motor along these lines has required long experience, and only within a few years have the difficulties connected with proper commutation and satisfactory heating been overcome. At present the series type of a. c. motor is being applied to railway service particularly on long interurban lines.

In appearance the series a. c. motor does not differ greatly from the series d. c. motor illustrated in Figs. 142, 143, and 144, except that it is equipped with a larger number of poles and a proportionately larger commutator.

A type of series motor invented in 1887 by Prof. Elihu Thomson is the repulsion motor, which has the armature short-circuited through brushes which bear upon a commutator. It is a form of induction motor and series motor combined and in a modified form is coming into use. One type of single-phase induction motor employs the repulsion principle in starting. A commutator is connected to the secondary of an induction motor and the brushes are short-circuited at starting. The motor then starts as a repulsion motor. When up to speed the brushes are automatically thrown off and the machine continues to rotate at nearly synchronous speed. This permits a greater starting torque than is possible with shading coils.

Shunt and Compound Wound d. c. Motors.

The shunt d. c. generator makes an excellent motor, and with the same e. m. f. applied as that produced as a generator will give nearly the same speed. As motors are usually much smaller than generators their mechanical construction is slightly different, but otherwise they are the same. The general appearance of a motor is shown in Fig. 139. From a circular frame project four pole cores and coils, the usual

number for d. c. motors of moderate size. The field ring is also machined at the ends to carry the circular bearing frames. The latter support self-oiling bearings, perfect alignment of which is secured by the method of concentric attachment to

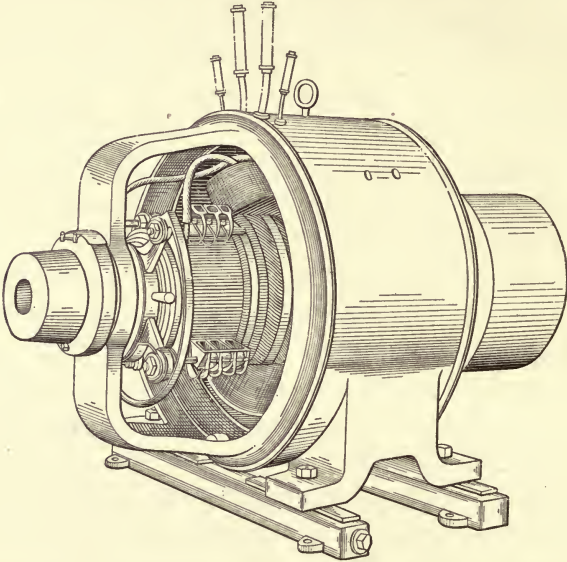

FIG. 139. View of d. c. shunt or compound-wound motor (Allis-Chalmers).

the field ring. The cast-steel pole cores, with their coils, are bolted securely to the field ring, the projecting pole shoes forming firm supports for the coils. The slotted armature surface carries machine-formed coils similar to those of the generator, and connected, usually, in a series or wave winding, requiring but two brushes. The brushes are small carbon blocks pressed by the spring fingers against the commutator and carried in brass holders attached to the rocker arm, all of a simpler construction than in large generators but otherwise similar. The general appearance of the motor parts is shown in Fig. 141.

Compound-wound motors are similar to the shunt motors

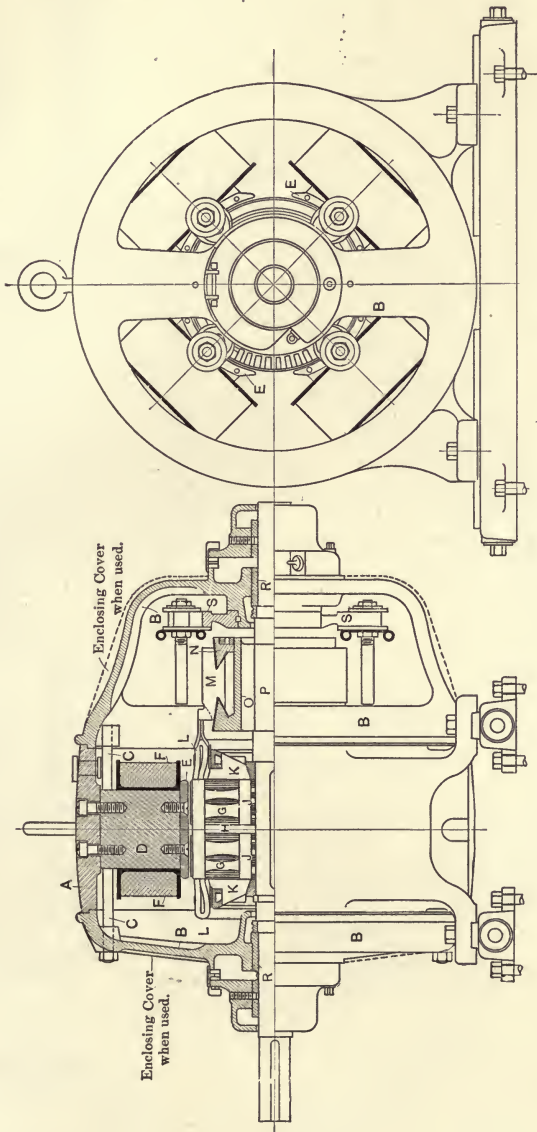

FIG. 140. Cross-section of d. c. shunt or compound-wound motor.



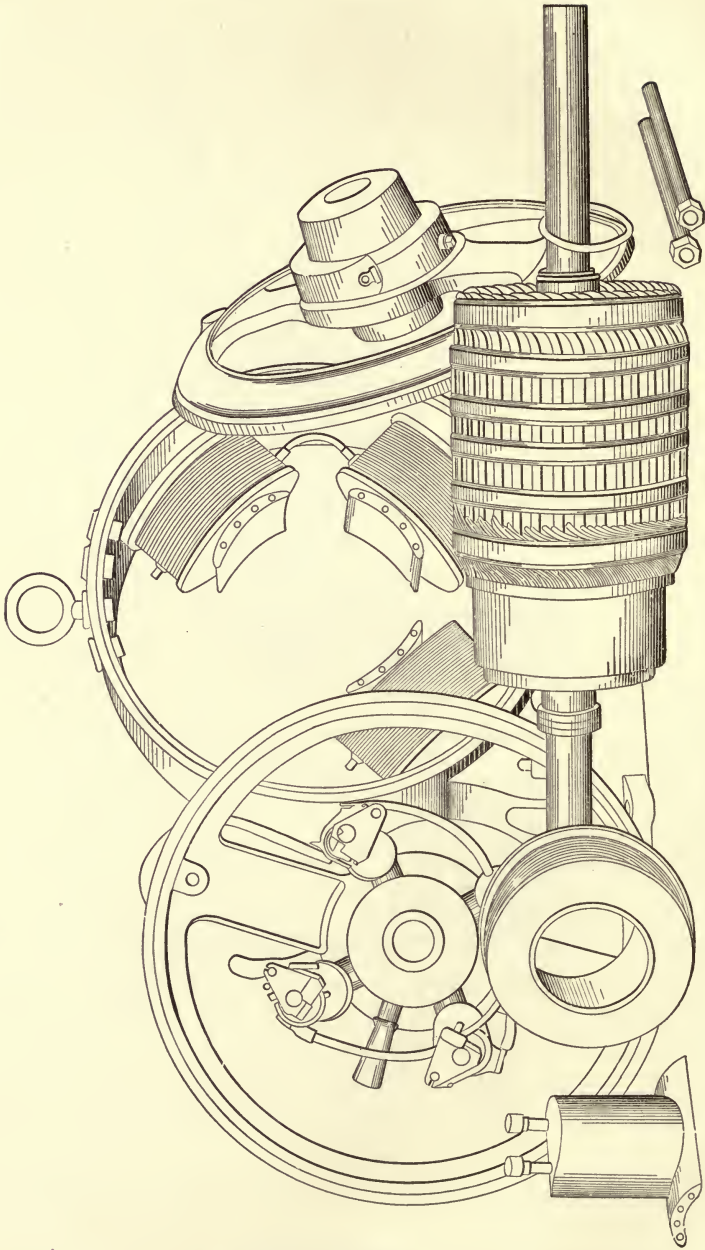

FIG. 141. Parts of d. c. shunt or compound-wound motor.

with the single exception of the series coil which is used in either of two ways and for two purposes:

(a) Connected in series with the armature, and in such a direction as to assist the shunt field, it produces a heavy torque at starting and is thus useful for elevator and other service which starts under full or excessive torque. The series coil may be cut out when motor has reached normal speed.

(b) Connected to oppose the shunt field, it weakens the field strength with increase of load and tends to maintain uniform speed. This differential connection is seldom necessary as shunt motors maintain a speed regulation quite satisfactory for most purposes.

Series d. c. Motors.

The series motor from the environment in which it has been forced to operate (that is, under street cars, on cranes, etc.) has taken on the peculiar form under which it is most familiar.

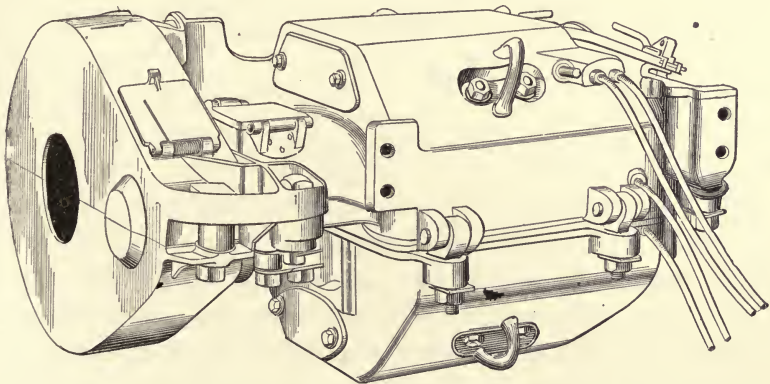

FIG. 142. View of series railway motor, closed (G. E. Co.).

As indicated in Fig. 142 the case is of such a shape that compactness and water-proofing are secured, and the means of attachment to the car axle, and support from the axle and truck

frame are provided. Simplicity and reliability are essentials of the series motor, the parts of which are reduced to the smallest possible number. Figs. 143 and 144 show the appearance of field magnet and armature. The frame is of cast

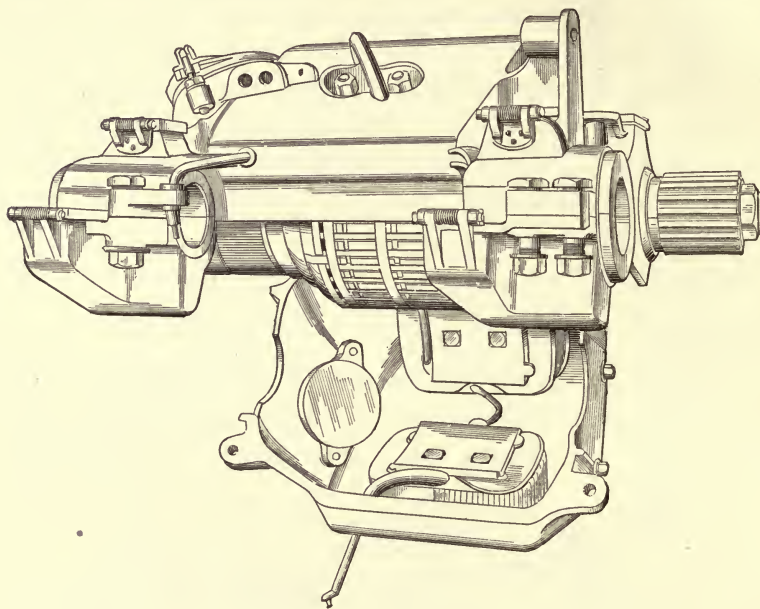

FIG. 143. View of series railway motor, open (G. E. Co.).

steel for lightness, and it serves as magnetic circuit and protecting case. It is of circular or octagonal form except in very large motors. From the case project four very short pole cores of solid or laminated steel and having pole horns to support the coils and spread out the air gap. The pole cores are bolted to the case.

The armature is necessarily large in proportion in order to enable it to produce the required torque. It is always series or wave wound, requiring two brushes which are placed 90° apart on top of the commutator. The same general form of

armature coils, Fig. 145, as those used in generators, are found in series motors. The plan of winding is similar to that of Fig. 80. The commutator is illustrated in Fig. 83. The brush

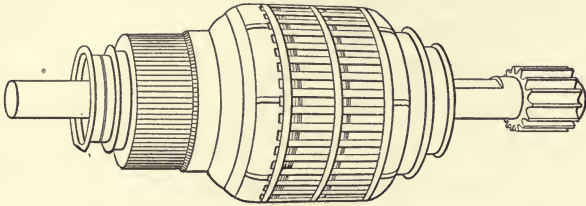

FIG. 144. Armature of series railway motor.

holding mechanism is of the simplest construction. The holders are mounted upon a frame of insulating material which is attached to the upper half of the case. They are adjustable

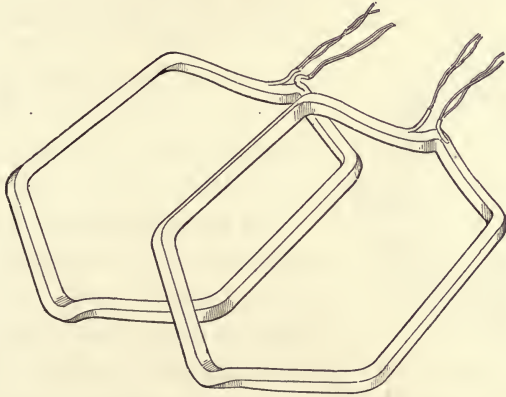

FIG. 145. Armature coils of series railway motor.

radially, but as a rule it is not necessary to provide for circumferential adjustment as the brushes remain on the neutral axis. They are thus placed because the motor must operate equally well in either direction, and while perfect commutation cannot be thus provided, it is satisfactory under the circumstances. When the motors are placed upon cars which run in

one direction only (single-enders) the brushes are shifted to the best position. The lead wires are carried through the case in insulating bushings, the terminals being brought out from both armature and field circuits to allow their connections to be changed in the controller.

In motors which receive so little attention as these, special attention must be given to the design of devices for keeping oil and grease out of the case. These would injure the insulation of the coils and produce sparking at the commutator. Oil rings are, therefore, placed on the shaft, and these discharge into chambers connected to the oil wells or allow the oil to overflow on the track. The bearings are made self-oiling or self-greasing by means of rings or wicks and will run for weeks without attention.

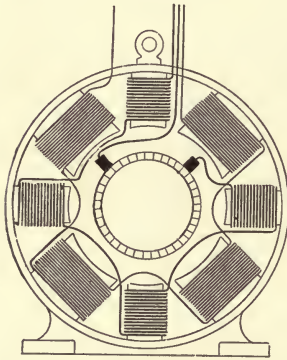

FIG. 146. Diagram of circuits of the interpole motor.

The description of the railway type of series motor will apply in general to the smaller models used in crane, elevator and other service requiring large starting torque and a speed varying inversely with load.

The Interpole Motor is the name given to a shunt, compound or series motor which has between the regular field poles, smaller ones with coils carrying all or part of the line current. A diagram of this arrangement is given in Fig. 146.

The function of the commutating or "inter" pole is to produce a reversing field for the coil undergoing commutation, that is, passing under a brush. The "reversing" field is thus stronger as the load is larger when the current is more difficult to reverse. Motors equipped with the interpole spark less under heavy load than those not so equipped. The result of the intro-

duction of this improvement is that motors can be designed for higher e. m. f. than before. The limit previously set was about 600 volts; with the interpole it may be 1200 volts. An increase of 100 per cent in the allowable line e. m. f. on railway circuits means a considerable saving in line loss or in line copper or the range of distribution may be proportionately increased.

Motor Characteristics.

The important curves of motors are those which indicate the degree to which they perform their work, that is, produce torque and speed, and their effect upon the electric circuit. The former include speed, current, torque-current, speed-torque and efficiency curves; the latter, power factor curves in case of alternating current motors.

Synchronous a. c. Motors.

As these motors produce a constant speed, the only important curves are the efficiency and those showing the effect of varying the excitation current. The efficiency curves are not substantially different from those of the same machine when operated as a generator, the efficiency in both cases being maximum with unity power factor. The field current has a marked effect upon the power factor of the current drawn by the armature and, therefore, upon the value of that current for a given output. A weak field produces a lagging current and a strong field a leading current. The curves showing the relation of armature to field current are known as "V" curves on account of their characteristic form, the bottom of the V corresponding to unity power factor in the armature.

Induction a. c. Motors.

In Fig. 147 are given the important curves for the induction motor previously illustrated. The curves are plotted with input as abscissæ and the several variables as ordinates. The

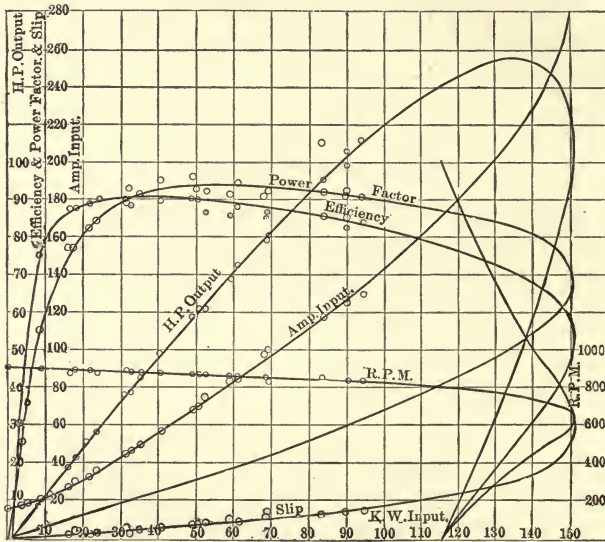

FIG. 147. Characteristic curves of a. c. induction motor (A. - C. Co.).

rated load of this motor is 50 horsepower corresponding to 42 amperes input.

The power curve rises uniformly until the motor is producing about twice the rated load after which it falls off, at first slowly, then rapidly, finally descending steeply to zero after the break-down point has been reached. That is, if the load on the motor is increased the input will proportionately increase during normal load and over-load. If the load becomes too great the motor will at first slow down, thus decreasing the power output. Finally, it will stop. The curve shows that this motor will produce a maximum of 128 horsepower and that if still further loaded it will break down when delivering about 100 horsepower.

The power curve cuts the axis at a point indicating an input of 1.5 k. w. when the motor is running light. This is required to overcome magnetic and friction losses.

The ampere-input curve begins at 8 amperes with no power input, indicating a magnetizing current of that value with low power factor. The curve rises at first gradually, because the power component of the current is small compared with the magnetizing component, then more rapidly and uniformly as the power factor increases. Finally, as the break-down point is approached the current rises rapidly due to the reduction of the power factor in that region.

The efficiency curve has the form usual in other electrical machines until the break-down point is approached. Here it falls off rapidly because the speed and output are decreasing while the input is increasing. Beyond the break-down point the efficiency promptly falls to zero.

The speed and slip curves show plainly that this is a constant speed motor, the speed falling off but slightly until the motor is heavily over-loaded. The slip at full load is three per cent, that is, the speed is within this amount of synchronism.

A different set of characteristics is produced when the secondary circuit has greater or less resistance, the set used for illustration representing the normal values for a constant speed motor of this size.

Series a. c. Motors.

The characteristic curves of series a. c. motors are very similar to those of the d. c. type, the details of which are given in the proper place. The only additional curve of importance is the power factor curve which in the working range of the motor is very similar to that already described for the induction motor.

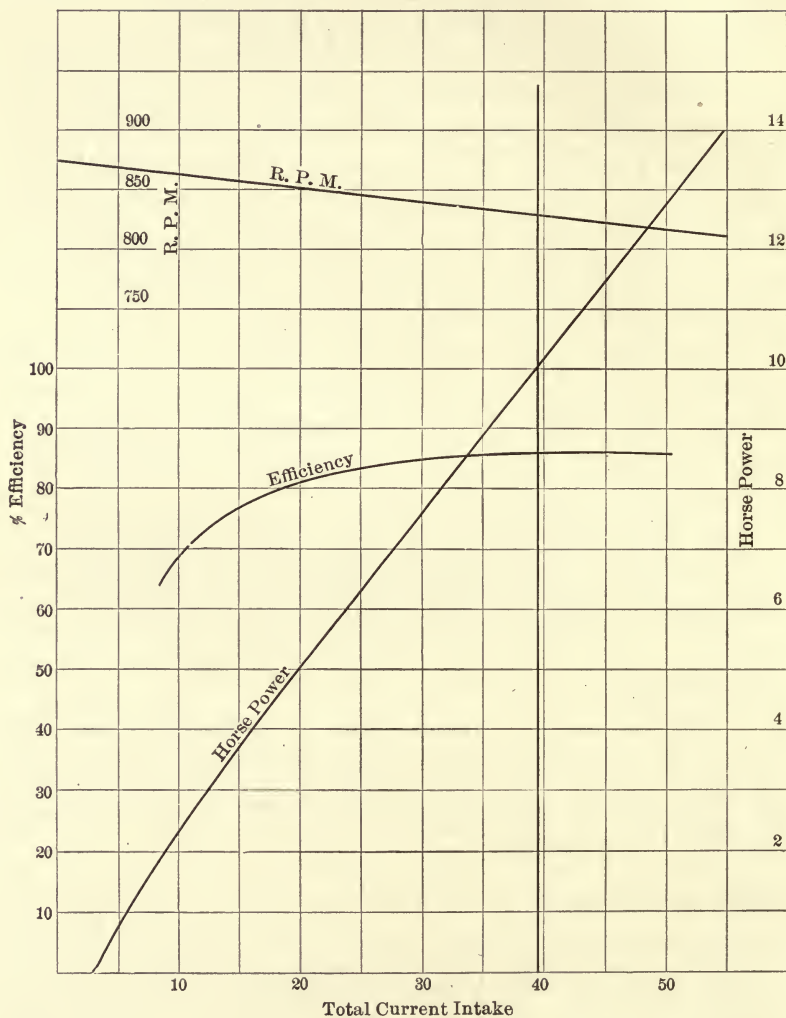

FIG. 148. Characteristic curves of d. c. shunt motor (A.-C. Co.).

Shunt and Compound=Wound d. c. Motors.

Fig. 148 represents a set of characteristic curves of the shunt motor previously illustrated, plotted on a current base.

The speed curve is practically straight and indicates a decrease from 875 r. p. m. at no load to 828 r. p. m. at full load (10 horsepower) or 5.4 per cent. This corresponds to the slip in the induction motor and indicates the similarity in speed characteristics between the two types.

The efficiency curve rises somewhat less steeply than in the last motor described, as at light load the field current is a large proportion of the total.

The horsepower curve starts at 3-amperes intake, the current necessary to excite the field and overcome the no-load friction. Before half load has been reached it becomes and continues practically straight.

The effect of a series winding connected to strengthen the field would be to decrease the speed and correspondingly increase the torque with any input current without substantially affecting the efficiency or horsepower curves. The heat loss in the series winding would have a slight effect upon these, but it would be negligible for all practical purposes. A differential winding would decrease the torque and increase the speed for a given current without material effect upon the efficiency and horsepower.

Series d. c. Motors.

The characteristic curves of series motors are radically different from those of the constant speed types. The torque affects both the speed and current to a greater extent. Fig. 149 represents a set of curves from the railway motor previously described.

The torque curve indicates that the torque produced is practically proportional to the current. At low values of current

the net torque is small on account of friction, but above a small value it follows a straight line law. As the same current flows through armature and field it might be inferred that the

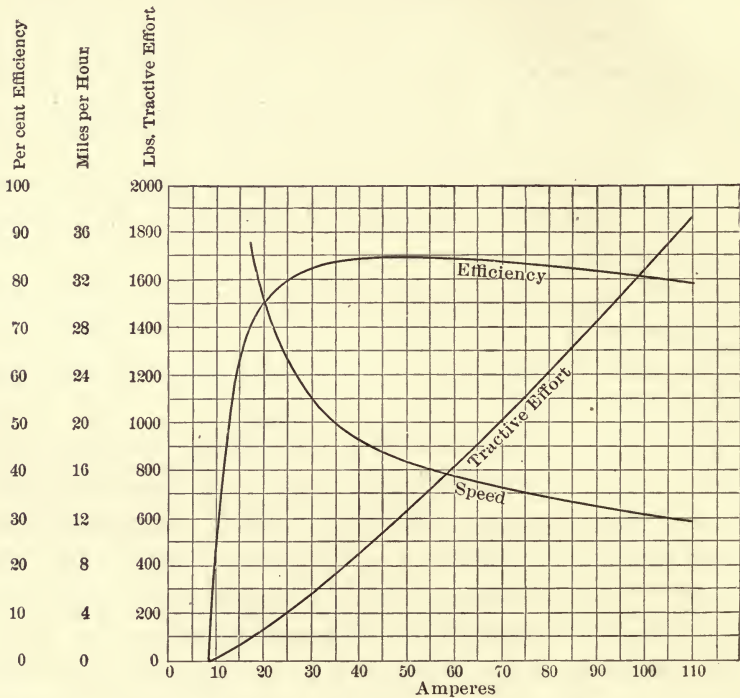

FIG. 149. Characteristic curves of series railway motor (G. E. Co.).

torque would be proportional to the square of the current. On account of the saturation of the magnetic circuit this is not the case.

The speed curve follows nearly a hyperbolic law for the reason that as the current increases the speed necessary to produce a counter e. m. f. equal to the line e. m. f. becomes smaller. As saturation of the magnetic circuit increases the speed tends to become constant until if perfect saturation were

reached the speed curve of the series motor would be similar to that of the shunt motor.

The *efficiency curve* of the series motor is practically the same as that of the shunt motor.

Motor Handling and Control.

The important operating features of all motors are:

1. Starting properly, that is, with safety to the motor and in accordance with the nature of the load.
2. Variation of speed or maintenance of constant speed after the motor has been brought to normal speed.
3. Protection of the motor against overload and against unduly sudden application of the load.

Starting.

When a motor is at rest it possesses only its resistance or impedance to the flow of current when an e. m. f. is applied. As a rule these are too small to prevent a rush of current injurious to the motor and to the line wires. Hence a device is necessary to limit the current to such a value as will produce the desired starting torque and no more. The nature of the load also imposes restrictions upon the rate of starting. For example, machine tools, street cars, elevators and crane loads cannot be started suddenly from rest even if the motor is capable of making such sudden starts. They require more or less gradual acceleration depending upon the operating conditions.

As soon as the moving part of a motor begins to rotate the conductors cut the flux of the field whether it be of a fixed or a rotating nature. This cutting generates a *counter e. m. f.* in the conductors which opposes the line e. m. f. and limits the flow of current. The moving part automatically takes such a speed that the difference between the line and counter

e. m. f.'s is just sufficient to send the required current against the resistance (in a d. c. motor) or the impedance (in an a. c. motor) of the circuit. For example, a 220-volt d. c. shunt motor is required to deliver 5 horsepower at the pulley. Its efficiency curve shows that it will do this at 80 per cent efficiency. The resistance of the armature is 0.3 ohm. What is the counter e. m. f.? To deliver 5 horsepower requires an input of 4660 watts in this case, corresponding to 21.2 amperes. The armature drop is, therefore, 6.35 volts, and the counter e. m. f. is 213.65 volts.

At start the possible current which could flow through the armature is 734 amperes, which would not only overheat the windings and cause excessive sparking, but would produce an injuriously rapid acceleration of the driven apparatus.

Synchronous Motors cannot be started under load but must be synchronized by an outside source of power. The operation is the same as that of connecting an alternator in parallel with a line. These motors, when polyphase, may be brought to speed by opening the exciter circuit and connecting the armature circuits to the line through lowering transformers (usually auto-transformers or motor-starters). The full line e. m. f. cannot be at once applied as the impedance of the armature is not sufficient to limit the current to a safe value. After the rotating part has attained some speed, the applied e. m. f. may be raised until full value is reached. The motor starts under the reaction of the rotating field produced by the armature, upon the eddy currents generated in the poles. The starting torque is weak, hence the motor must be started light, i. e., without load. When synchronous speed has been reached the field may be excited and the starting is complete.

Starting by the method described, requires the use of a large current of low power factor, and it may have a disturbing

effect upon the regulation of the line. It is better in many cases to start by means of an auxiliary induction motor, which if direct connected must be provided with a smaller number of poles than the main motor to allow it to bring the latter to a speed slightly above synchronism. This practice is indicated in Fig. 121, where the rotary converters have direct-connected to their shafts, auxiliary induction motors for starting purposes.

The rotary converter, a combination of synchronous motor and d. c. generator, may be started from the d. c. end if some other machine is already generating direct current. On a large system employing several converters, and especially if a storage battery forms part of the equipment, direct current is usually available. The converter is brought to speed as a d. c. separately excited or shunt motor and it is synchronized as before. Even in such a system as this it is not desirable to depend entirely upon direct current for starting, but one or more converters should have auxiliary starting motors.

Induction Motors. *Polyphase Motors* of small size (say up to 3 horsepower) may, if they are unloaded, be connected directly to the circuits. The revolving part is light and it responds so quickly to the e. m. f. that excessive current is drawn for but an instant. Such a motor usually forms but a small part of the load upon a line, and hence its starting current does not greatly affect other apparatus connected thereto. All large squirrel-cage motors, and small ones of the same type, which must be started under load, are supplied with a small e. m. f. at first, which is gradually increased as acceleration proceeds. The graduation of e. m. f. is provided by an auto-transformer with its extreme terminals connected to line and intermediate taps to motor through sliding contacts. An arm controlled by a lever located outside the transformer case travels over

these contacts and gives the operator the desired control over the duration of start. When the motor reaches speed the starting transformer is cut entirely out of the circuit to save exciting current.

Induction motors with *phase-wound* secondaries are started with resistance in the secondary circuits, which are wound in this way to permit the introduction of starting resistance. The primary circuits are connected directly to the line, and the secondary resistance is large at first and is cut out as acceleration proceeds. The resistance may be external, in which case if the secondary is revolving the current is brought out to the resistance box through slip rings. The resistance may also be carried within the armature and manipulated by a lever and slip collar sliding upon the shaft. (The latter practice is preferred in this country for phase-wound secondaries.) If a stationary secondary is used the introduction of resistance is simpler, but the primary current must then be taken into the revolving primary through slip rings. The phase-wound motor has very satisfactory starting qualities and draws little excess starting current. Hence it is preferred for applications in which the effect upon the line regulation is important, e. g., when incandescent lamps are operating upon the same circuit, or for driving loads which require a gentle increase of starting torque.

Single-phase induction motors operate with reasonable satisfaction when they have been brought to speed. The principal difficulty is in starting them. This difficulty is overcome in several ways of which the following are the principal ones:

Shading coils, small copper links, are placed around the primary core overlapping and linking with the primary coils. As the flux changes in these shading coils, currents are produced which are out of phase with those in the primary coils.

The result is the production of an irregular rotating field which is sufficient to start the secondary if the mechanical resistance is not great. As soon as the secondary starts, it cuts the flux of the field and generates currents which are also out of phase with the primary current and which increase the strength of the revolving field. The rate of acceleration continues to increase until normal speed is reached. This plan is adapted only to very small motors.

Hand starting may be used to supplement or replace the effect of the shading coils. By these means the secondary is forced to cut the field and by combination of its m. m. f. with that of the primary a rotating field is produced as already described.

Phase-splitting devices may be employed to produce, in a divided circuit, currents out of phase with each other. For example, if a resistance and a reactance are connected in parallel they will draw from the same line currents having a maximum possible phase displacement of 90° . If the motor to be started have an auxiliary circuit like the second phase of a two-phase motor, one of the currents in the divided circuit may be sent through this while the other current passes through the main winding. A rotating field will then be produced and the motor will start with a weak torque. The starting device may be cut out when the motor reaches speed.

The auxiliary winding may be short-circuited through a condenser, which draws a leading current, and this combined with the primary current will produce the desired rotating field. Such a condenser arrangement need not be cut out when the motor is at speed, for practically no power is consumed in it. The presence of the wattless leading current also is beneficial as it neutralizes the lagging component of the primary current and improves the power factor thereby. This plan is used successfully in motors of a few horsepower

capacity. The condenser is too bulky for use with large motors.

The *commutator* starting device, already mentioned, is in successful use. The secondary winding of the motor is connected to a commutator as in a direct current armature. The brushes are short-circuited at starting and the primary generates current in the secondary by transformer action but cannot produce a rotating field. The brushes and short-circuit connections force the secondary currents to flow in such directions that a considerable net starting torque is produced. The brushes are cut out and the commutator is short-circuited as soon as the armature reaches speed.

Series a. c. motors may be started with resistance in series, but in railway service, their most important field of application, they are started as follows: A transformer, connected across the line, is provided with numerous secondary taps from which various e. m. f.'s may be secured. The e. m. f. applied to the motor terminals is increased by including more secondary transformer turns between the points of connection. This is done in the controller where sliding contact segments pass under contact fingers, making the required connections.

A second plan for controlling the starting current is to connect in series with the motor a variable reactance coil, which reduces the e. m. f. by introducing its own counter e. m. f. This scheme is not in great favor because the current drawn through such a regulator has a low power factor and hence produces a disturbance in the regulation of the line.

D. C. shunt motors are started with adjustable resistance in series with the armature. A starting box, similar to that shown in Fig. 151, is usually employed. The field circuit is *first* closed so that the flux may attain its normal value before any current flows through the armature. If the field and

armature circuits are closed at the same instant, excessive current will be drawn by the armature because of the inductance of the field circuit. The inductance prevents the field current from reaching its full value instantly. The armature is *next* connected to the line through the resistance, the value of which is selected to limit the current to a certain maximum value. The resistance conductor in the starting box is usually small in proportion to the current carried as the resistance is in circuit for but a few seconds. The starting resistance should, therefore, never be left in circuit continuously. The resistance is gradually cut out as the motor accelerates, the duration of the acceleration period being determined by the amount of mass to be accelerated. The control of the starting resistance is in many cases made automatic by means of a device for moving the resistance box lever. This may be a spring, solenoid or a motor and the motion may be resisted by an adjustable air or oil "dash pot" to insure steady motion. Such a device is absolutely essential in elevator service. An elevator car operator cannot be trusted to control the starting of the motor, hence a switch is opened or closed from the car, and the controller, located near the motor, allows it to accelerate at a predetermined rate.

Compound wound d. c. motors are started like shunt motors, except that the series winding sometimes requires special switch connections. If the series winding is added to produce a powerful starting torque, it may be short-circuited after speed has been reached. The motor will then heat less and maintain a better speed regulation than if the series coil is left in circuit. If the load is of such a nature that good speed regulation is not necessary, and if sudden heavy over-loads are apt to occur the series winding need not be cut out. If the series winding be connected differentially it may be short-

circuited at starting, as otherwise it would reduce the torque. The short circuit may be removed when speed is reached.

Series d. c. motors are started with resistance as already described. The series motor starts better than the shunt motor for the reason that as the field flux is greater with a larger current, the excess starting current need not be as great to produce a given starting torque. In railway work, the principal application of the series motor, there are always at least two motors upon the same car and these may be connected in series at the instant of starting. The same starting current then serves for both motors. One-half the starting current for a given torque is thus saved and a smaller starting resistance may be used. When the starting resistance is all out and the acceleration has proceeded as far as possible with the motors in series (that is, to about one-half speed) they are connected in parallel, in series with the resistance, which is again gradually cut out.

The connections for the changes mentioned are made in the controller located at the end of the car. In equipments of ordinary size, the motorman rotates by hand a cylinder upon which are mounted insulated copper segments which bridge across contact fingers connected to the various parts of the equipment (armatures, field coils, and resistances). The necessary combinations of connections are thus made. In very large cars the same function is performed by large switches, located under the car, operated by air-driven pistons or electric solenoids. The latter are under the motorman's control.

Speed Control.

The primary function of any motor is to produce a desired speed against a load resistance. This speed requirement is often the determining factor in the selection of motors for a given service. By way of review of the speed characteristics

of the various motors the following summary will be useful in studying the subject of speed control.

<i>Type of Motor.</i>	<i>Speed Characteristics.</i>
Synchronous, a. c.	Absolutely constant.
Induction, a. c.	Practically constant, falls off slightly with increase of load.
Series, a. c.	Varies inversely with load.
Shunt, d. c.	Similar to induction a. c.
Compound, d. c.	With differential winding may be designed for constant speed, otherwise combines shunt and series characteristics.
Series, d. c.	Same as series, a. c.

Synchronous a. c. motors have a speed determined solely by the line frequency and the number of field poles. Hence unless these are altered there is no control of the speed of such motors.

Induction a. c. motors are known as constant speed motors, although the speed falls off by a few per cent from no load to full load. The synchronous or no-load speed is fixed by the line frequency and the number of poles, and the only way to alter the running speed is to increase the slip. This may be done by inserting excessive secondary resistance, which is sometimes done in motors of small size in order to force them to give "series" characteristics. For elevator and crane service this is not objectionable in spite of the reduced efficiency and increased secondary heating. This practice of forcing series characteristics from a naturally constant speed motor should be considered exceptional. The series a. c. motor gives such characteristics naturally.

Series a. c. motors are best varied in speed by the method already described for starting them. By means of the multi-tap transformer a variable e. m. f. is efficiently produced and the motor speed is thus readily varied.

Shunt and compound-wound d. c. motors while, like induction motors, normally of constant speed characteristics, permit efficient speed control over a wide range of two methods.

- (a) By variation of the applied e. m. f.
- (b) By variation in the field strength.

As before noted, a motor tends to take such a speed that the counter e. m. f. is equal to the applied e. m. f. less the drop in the armature. Hence other conditions being the same, the speed will be proportional to the applied e. m. f.* The

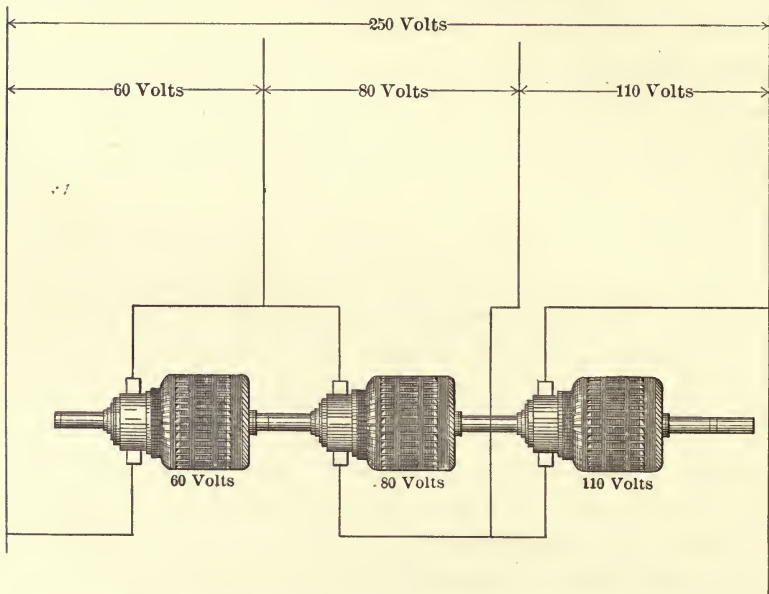

FIG. 150. Diagram showing multi-voltage circuits for shop motors.

applied e. m. f. may be reduced by using some of it in resistance but this is not good practice because it is inefficient. A better plan is to provide several line e. m. f.'s by a multi-wire

* This does not apply to the speed of a. c. synchronous and induction motors in which the line frequency is the controlling factor rather than the counter e. m. f. of the motor.

or multi-voltage system such as that illustrated in Fig. 150, which is used for driving machine tools. By the use of several armatures producing different e. m. f.'s a wide range of e. m. f. is obtained.

Resistance inserted in the field circuits of the motors produces variable speed by altering the field strength. As the armatures must generate a counter e. m. f. practically equal to the line e. m. f., they must run faster in a weak field than in a strong one. Hence an increase in field circuit resistance results in an increase of speed through a weakening of the field and *vice versa*. This principle cannot be applied too far for the reason that if the field is over-weakened sparking at the commutator results as there is not enough flux left to properly reverse the current in the armature coils.

By combining the variable e. m. f. with the variable field regulation it is possible to adjust the speed of the shunt motor to meet all practical requirements. With a given e. m. f. and adjustment of field current the speed of the shunt motor will remain practically constant, while that of a compound-wound motor will rise or fall according to the effect of the series winding.

Series d. c. motors respond to changes in applied e. m. f. just as do shunt motors and for the same reason. In practice the change in e. m. f. is secured by connection of the motors in series, thus dividing the e. m. f. equally between them. The speed is then determined by the load resistance. The speed may be further affected by changing the field strength. Formally this was done by altering the number of field turns, but a more satisfactory method is to shunt the field coil with a diverting resistance, frequently called a "diverter." The field m. m. f. is thus reduced, the flux is lessened and the speed is increased to produce the required counter e. m. f.



Motor Applications.

From the characteristics of the motors their several fields of application naturally result. For any case a type of motor is selected which gives, with the available supply, the desired speed regulation, produces the necessary torque and operates with minimum attendance and depreciation. In small, isolated plants the variety of current supply may sometimes be determined by the type of motor which it is desired to use. In most cases the motor is either selected to suit the supply, or transforming apparatus is installed to adapt the two to each other.

Synchronous a. c. motors find their principal application in transforming current from one variety to another. The rotary converter is a combination of synchronous motor and d. c. generator, the same armature winding being used for both purposes. A lap wound d. c. armature is provided with two, three, four or six collector rings for a single, three, two or six-phase converter respectively. If brushes were arranged to bear upon the bonding rings on the back of the armature shown in Fig. 78 the whole would form a rotary converter armature. In practice the rings are arranged in the same form as in the alternator. Such a converter will operate as a synchronous motor,* and it will deliver current like any d. c. generator. Converters are used in railway substations principally.

The synchronous motor is also used to drive generators either a. c. or d. c., and in these "motor-generator" sets the machines are usually mounted upon the same bed plate, with

* Operated as a motor from the d. c. end and giving out alternating current, the machine is called an "inverted" converter. It is not in common use as such. Driven from an outside source of power and giving out both direct and alternating current, it is called a "double-current" generator. It is so used to a limited extent.

a stiff or flexible coupling between. When a synchronous motor drives an a. c. generator of the same number of phases but different frequency, it is given the self-defining name "frequency-changer."

Whenever absolutely constant speed is desired from an a. c. line the synchronous motor is the machine adopted. It is seldom used in small sizes on account of the difficulty in starting.

Induction a. c. motors are used in all lines of work in which fairly constant speed, fair starting qualities and simplicity of construction are the requirements. The motors are in keen competition with the d. c. shunt motor (their operating characteristics are very similar) except in variable speed drive. Among the applications are: the a. c. end of motor-generator sets of all kinds; shop drive, especially line shaft drive, as contrasted with individual machine tool drive; ventilating fan drive; tool and other drive in which fairly constant speed is desirable; small residence fan and machine drive (a. c. lighting current being usually the only available power source).

Series a. c. motors are at present used almost exclusively for railway service to which they are peculiarly well adapted. They give a large starting torque and as they are single-phase they require the use of but one trolley wire (the rails being used as the return). They are heavier than the series d. c. motor of the same rated output, hence are used mainly on long interurban lines where the transmission system is a predominating factor. Direct current motors used on these lines require rotary converter substations.

Shunt d. c. motors are pre-eminently adapted to direct driving of machines requiring speed adjustment. They are also in competition with the induction motor in constant

speed work. The latter has the advantage of simplicity, but the manufacturers of d. c. motors have, through long experience, succeeded in developing a type of motor with almost perfect commutation. Hence commutators and brushes give comparatively little trouble.

Compound d. c. motors are applied to a limited class of service in which the requirements are large starting torque and reasonably constant speed when full speed is reached. The best example of this is the elevator. Differential compounding meets the very occasional requirement of absolutely constant speed or a speed increasing with the load. Such requirements are all of a special nature.

Series d. c. motors are almost perfectly adapted to service requiring large starting torque and in which it is desirable or allowable to permit the speed to vary greatly with the load. Hence the prevalence of this type of motor in railway service. Take for example a railway car climbing a grade. A shunt motor would drive it at practically the same speed as when upon the level, resulting in a destructive load upon the motor unless it is large enough for the heaviest demand. A series motor automatically slows down to such a speed that the desired torque is produced without unnecessary draft of current. On the level the motor speeds up until the current is cut down to the value just necessary to overcome the mechanical resistance. Further, as railway service involves frequent stops, the excellent starting qualities of the series motor are utilized.

Another example of series motor application is in electric crane service, a very important field. Such a crane normally requires three motors: one to raise the load, a second for transverse motion of the trolley, and a third for longitudinal travel of the crane as a whole. The requirements are very similar to those of the electric railway.

Protection Against Over-load.

Two kinds of circuit opening devices are used in motor service: fuses and mechanical circuit breakers. Fuses are made of lead-tin-bismuth alloys of various proportions, and they are usually enclosed to prevent damage in melting, which occurs very violently under short circuit. In addition to fuses, which are usually installed and depended upon in cases where other devices fail, an automatically operated switch is often installed. Such a circuit breaker is closed against the resistance of a spring and is held in the closed position by a trigger. The line current, or a current proportional thereto, passes through a solenoid which attracts an iron armature attached

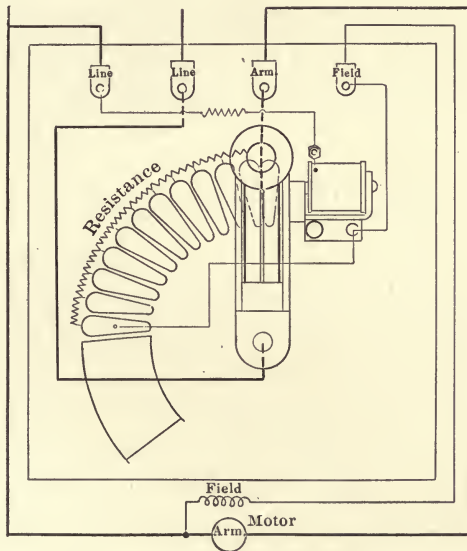

FIG. 151. Starting box for d. c. shunt motor.

to the trigger. When the current is excessive the trigger is tripped and the switch opens. Such an arrangement is an "over-load" circuit breaker. It is sometimes a separate piece

of apparatus but in connection with shunt d. c. motors may form a part of the starting box. When this plan is employed the trigger releases the switch when the current becomes excessive, and it is restored to the starting position by the spring.

An additional circuit breaker is also desirable in motor installations to protect the motor in case the line e. m. f. should fail and should then be restored, a contingency which frequently arises. This device usually forms a part of the starting box and consists of a second solenoid the function of which is to release the trigger when the line e. m. f. falls below a predetermined value. This is illustrated in Fig. 151.

Fuses are selected and circuit breakers adjusted to open the circuit when the current exceeds a certain value. This is usually considerably more than normal full-load current as excess starting current must be provided for.

CHAPTER XI.

ELECTRIC LIGHTING AND HEATING.

COMMERCIAL ELECTRIC LAMPS.

Incandescent Lamps: Incandescent Lamp Manufacture — Operation of Incandescent Lamps — The Nernst Lamps.

Arc Lamps: General Principles — The Carbon Arc — New Forms of Arc — Construction of Arc Lamps — Open and Enclosed Arcs — Light Produced by Arc Lamps.

The Vacuum Tube Lamp.

The Mercury Vapor Lamp.

Fields of Application of Electric Lamps.

Light and Illumination.

Efficiency of Light Production.

Units of Light and Illumination.

Electric Heating.

Commercial Electric Lamps.

Incandescent Lamps.

Incandescent Lamp Manufacture. The incandescent lamp is a device for transforming into light a part of the heat generated by the passage of an electric current through a solid of high resistance. At low temperature all the energy absorbed by the substance passes off as heat, but above a temperature of 350° C. light is given off, increasing in intensity up to the melting point. The incandescence of the filament of such a lamp is caused by the rapid motion of the particles, and decomposition of the filament is in general prevented by the extraction of the air from around it. The filaments of incandescent lamps may be of carbon or of highly refractory metal. Plati-

num was the first material used for this purpose. It did not prove satisfactory on account of the distillation of the metal at the temperatures necessary to produce incandescence. The metal filament was replaced by one of carbon in the development of which Edison tested every available substance to determine the best source of the carbon. Threads of different kinds and fibers of numerous plants were experimented with. At the present time carbon filaments are formed from cellulose.

A complete lamp consists of the following parts:

- (a) The bulb.
- (b) The filament.
- (c) The base, which includes the support for the filament.
- (d) The connecting wires between the filament and the base.

The manufacture of the lamp consists of the following processes:

- (a) Forming the filament.
- (b) Carbonizing the filament.
- (c) "Flashing" the filament.
- (d) Blowing the bulb.
- (e) Mounting and sealing the filament and placing in the bulb.
- (f) Exhausting the air from the bulb.
- (g) Testing and rating the lamp.

Carbon filaments are made either from vegetable thread, which has been changed into a form called amyloid by treatment in sulphuric acid, or from wool which has been digested into cellulose form. The thread is drawn through die plates forming a tough fiber of uniform section. The cellulose solution is "squirted" through a die plate into alcohol which sets it into a tough fiber similar to that produced by the first method. The prepared fiber is wound upon carbon blocks of a proper form to produce the required shape of loop. The blocks with the wrapping of fibre are then placed in a carbon

box and surrounded by carbon dust. The box is supplied with vents to permit the exit of the volatile matter in the fiber. The box with its contents is gradually raised to a white heat and allowed to remain at a high temperature until all volatile matter has been removed. After it has cooled down slowly the filaments are removed in the form of pure but granular carbon. They are temporarily mounted for electrical connection to an electric circuit and are heated

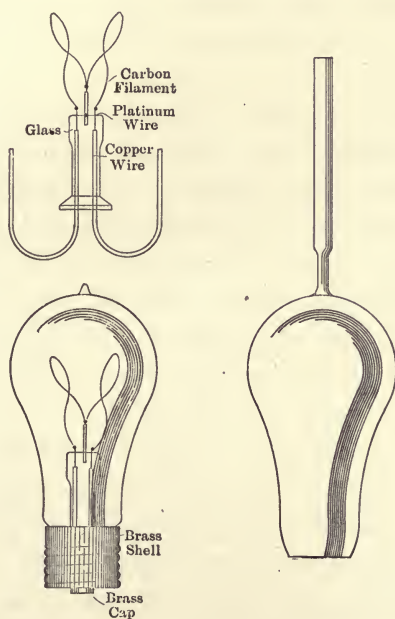

FIG. 152. Parts of a carbon filament incandescent lamp.

to a high temperature in a hydro-carbon gas by means of the electric current. The hydro-carbon gas is decomposed by the heat and deposits a layer of carbon upon the filament. This layer is densest on the hottest parts of the filament, where it is most needed to produce a uniform section. The process described is known as "flashing" and when the

filament is removed from the vessel in which the operation is carried on, it has lost its granular appearance and has a smooth, hard, and apparently metallic surface. The filament is thus rendered more durable and better suited for the production of incandescence. The ordinary carbon filament lamp is "flashed" at only a moderate temperature. A recent improvement in this line consists in depositing the surface carbon at a much higher temperature. The filament then becomes still more metallic in character and may be operated at higher efficiency. Such a filament is known as a "metallized" filament.

The filament is mounted upon platinum wire supports by means of a carbon paste deposited upon the joints. This method takes the place of the electro-plating and soldering method once employed. Platinum is the only metal available for the leading-in wires, as its coefficient of expansion is the only one sufficiently near to that of glass. The platinum wires are then sealed into a tube flared at one end for attachment to the bulb, which has been prepared meanwhile by blowing either from tubing or in molds direct from the pot. After the tube with the filament has been sealed into the bulb the air is removed by means of a vacuum pump through a small piece of tubing sealed on the end of the bulb for this purpose. After the removal of the air this tip is sealed over. The lamp is then mounted in porcelain in the brass base and the terminals are soldered to the contacts.

The manufacture of metal filament lamps which has recently attracted attention, involves entirely different manufacturing processes. When ductile metals like tantalum are employed the production of the filament is a comparatively simple matter, although it requires great skill on account of the small diameter of the wire. The conductivity of the metals is very much higher than that of carbon. Hence the use of a long

wire of small diameter is necessary. When non-ductile metals, such as tungsten, are used, a round-about procedure must be followed. As an example, one method of producing a tungsten filament is as follows: A carbon filament is first prepared

and this is electro-plated with metallic tungsten. The filament is then "flashed" in a hydrogen atmosphere at a very high temperature, resulting in the absorption of the tungsten by the filament and the production of tungsten carbide. The carbon is next removed by surrounding the filament with tungsten oxide and heating to a high temperature. The carbon is oxidized and passes off in gaseous form leaving the metallic filament ready for use in incandescent lamp construction.

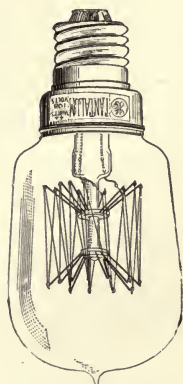

FIG. 153. The tantalum filament incandescent lamp.

Operation of Incandescent Lamps.

The amount of light given off by an incandescent lamp depends entirely upon the temperature at which it is

operated. Lamps are purchased for operation at a certain e. m. f. with specified consumption of watts per candle power. The average values for the carbon filament lamp lie between 2.5 and 4 watts per candle power. By operating at an e. m. f. greater than the rated value more light will be produced and at a higher efficiency. The lamp will, however, "burn out" sooner because the filament will distill more rapidly. There is, therefore, a compromise between length of life and efficiency of operation. The relation of life and candle power to e. m. f. is shown graphically in Fig. 154. The practical efficiency at which the filaments should be used depends largely upon the regulation of the

line e. m. f. If perfect regulation is to be had, high efficiency lamps may be used. Where the e. m. f. varies between wide limits, say 10 per cent or more, low efficiency lamps are abso-

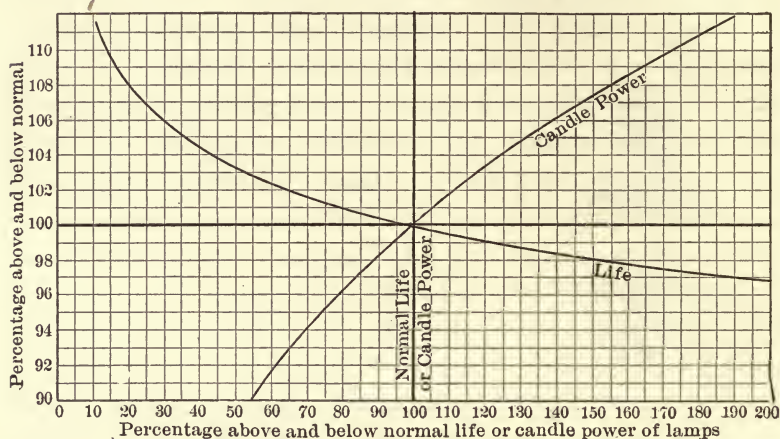

FIG. 154. Curves showing the effect of variation in voltage upon the candle power and life of carbon filament incandescent lamps.

lutely necessary. Metal filaments have in general a higher efficiency than carbon filaments, and they are less sensitive to changes of line e. m. f. on account of their positive temperature coefficients. The same general principle of the relation of life to efficiency applies to them and determines the best values to be adopted for a specific case.

To illustrate the variation of efficiency with e. m. f. assume that a 16 candle-power lamp consumes 56 watts at 100 volts. At this e. m. f. it is a 3.5 watt lamp. If the e. m. f. be increased to 104 volts, 60 watts may be consumed and 20 candle power produced, the power consumption then being 3 watts per candle. A further increase of e. m. f. to 110 volts may produce a candle power of 28, and a watt consumption of 78, or 2.8 watts per candle. The efficiency at which it is best to run an incandescent lamp is purely a commercial

matter. As the efficiency increases with increase of e. m. f. the life is shortened and a point is reached at which the cost of renewing the lamps is equal to the saving of power. This point is obviously the limit of economical increase of lamp efficiency. The economic or useful life of the lamp ceases long before it "burns out." The term "smashing point" has been suggested as a name for the end of the useful life. The following problem will serve to illustrate what is meant by the term "smashing point."

Illustrative Problem in the determination of the economical life of an incandescent lamp.

Given the following data:

Cost of electrical energy, 7 cents per k. w. hour. Initial power consumption of lamp, 3.2 watts per candle power. Cost of

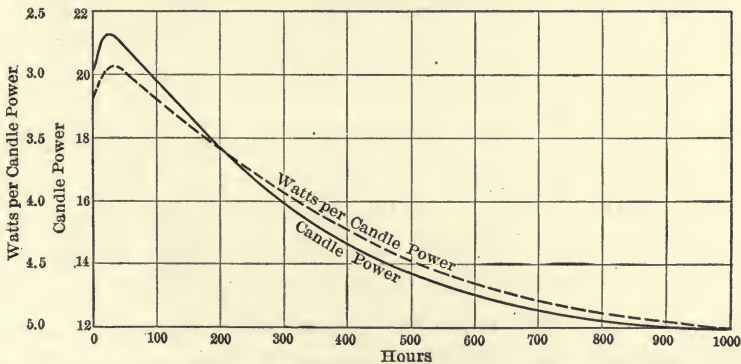

FIG. 155. Curves showing the relation of life, candle power and power consumption in carbon filament incandescent lamps.

lamp, 16 cents each. The curves of life and candle power, life and watts per candle as given in Fig. 155, secured from tests.

The calculation may be made on the basis of any number of hours without affecting the result. In this case one thousand hours are selected for convenience. The following table shows the details of the calculations, and the curve in Fig.

156 is a graphical representation of the results. The minimum cost of a thousand candle-power hours of operation for this case is about 26.5 cents, and to obtain this minimum cost

Lamps smashed after	No. of Lamps required in 1000 hours.	Mean c. p.	Total c. p. hours.	Lamp cost, in cents per 1000 c. p. hours.
<i>hours</i>				
100	10.00	20.5	20500	7.80
200	5.00	19.7	19700	4.06
300	3.33	18.7	18700	2.85
400	2.50	17.9	17900	2.24
500	2.00	17.2	17200	1.86
600	1.65	16.5	16500	1.60
700	1.43	16.0	16000	1.43
800	1.25	15.5	15500	1.29
900	1.11	15.1	15100	1.18
1000	1.00	14.7	14700	1.09

Mean Watts per c. p. from curve.	Total k. w. hours.	K. W. hrs. per 1000 c. p. hours.	Energy cost per 1000 c. p. hours.	Total cost per 1000 c. p. hours.
3.10	63.5	3.10	21.70	29.50
3.22	63.4	3.22	22.55	26.61
3.38	63.2	3.38	23.65	26.50
3.54	63.4	3.54	24.80	27.04
3.64	62.6	3.64	25.50	27.36
3.83	63.2	3.83	26.82	28.42
3.96	63.4	3.96	27.75	29.18
4.08	63.4	4.08	28.60	29.89
4.18	63.2	4.18	29.30	30.48
4.26	62.6	4.26	29.85	30.94

requires that the lamps be replaced when they have burned for somewhat less than 300 hours. A different cost of lamp or a different cost of energy will affect these results, and the conclusion will not be the same for a different initial efficiency of lamp.

The "smashing point" as described does not apply as well in the case of metal filament as in carbon filaments for the reason that the candle power does not fall off as rapidly in this case as in the other. The efficiency is also better maintained. Whether or not an incandescent lamp should be allowed to

burn itself out depends entirely upon the decrease in its efficiency from the beginning to the end of its life. With the ordinary carbon lamp this decrease may amount to one-third of the candle power.

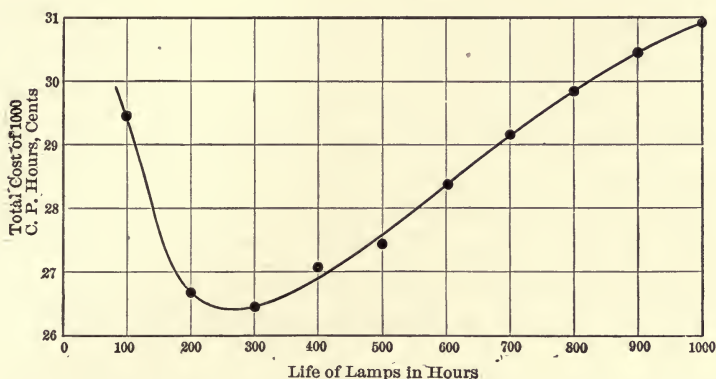

FIG. 156. Curves between useful life and total operating cost of carbon filament incandescent lamps.

The Nernst Lamp. The standard forms of incandescent lamp require a vacuum protection for the filament in order that it may not be oxidized. In the Nernst lamp a filament of highly refractory rare earth is employed, and it is operated in the air. The filament is protected only by its very high melting point. Such a material is a non-conductor when cold and becomes a conductor when heated. The Nernst lamp, therefore, has incorporated with a glower, as the filament is called, a heating device to bring it to a conducting temperature. A filament of this nature has a negative temperature coefficient, that is, its resistance decreases as the temperature increases. Hence it is unstable and would be soon burned out if connected directly across the supply mains. To protect it there is inserted in series a resistance having a positive temperature coefficient. Iron wire is well adapted to this pur-

pose. This ballast compensates for the decrease in resistance of the glower and maintains a fairly uniform current through it. To protect the iron wire from oxidization it is enclosed in a glass tube from which the air has been exhausted.

In the American type of lamp the glower is held in horizontal position with the heater directly above. The heater consists of one or more clay tubes wound with high resistance wire and covered with a protecting layer of fire clay. As the heater is only needed at starting it is cut out of circuit by an automatic cut-out as soon as current flows through the glower.

The Nernst lamp has an efficiency much higher than the ordinary incandescent lamp. The light is of an excellent quality and when distributed through a frosted globe is very satisfactory for interiors or for street lighting. The mechanism

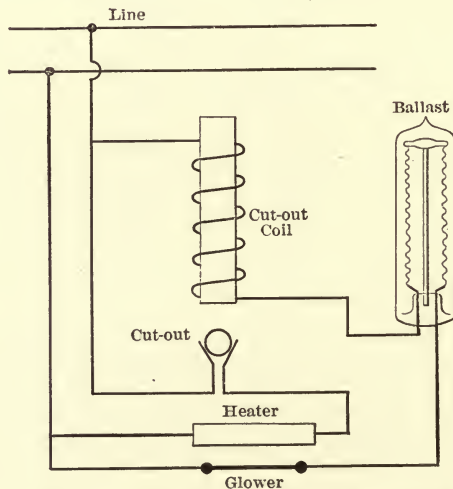

FIG. 157. Diagram of circuits in the Nernst lamp.

makes it necessarily somewhat expensive, and in this respect it occupies a position midway between the incandescent and the arc lamps. Fig. 157 shows in diagram the arrangement of the various parts of the Nernst lamp.

Arc Lamps.

General Principles. The name electric arc, derived from the arched form of the vapor absorbed in Davy's horizontal lamp, is given to the stream of incandescent vapor which connects the terminals of a circuit when these are drawn apart, and when there is sufficient e. m. f. maintained between them. Practically any metal or other material which will form a conducting vapor when heated will produce an arc in this manner. The hottest arc is that produced between carbon terminals, which requires a higher e. m. f. than metals. The following table from Fleming indicates the e. m. f. required for a number of substances. A few metals, of which zinc is most common, do not form an arc readily and are for this reason given the name *non-arcng metals*.

TABLE SHOWING THE NUMBER OF VOLTS REQUIRED TO MAINTAIN AN ARC BETWEEN TERMINALS OF DIFFERENT MATERIALS (FLEMING).

<i>Material.</i>	<i>Initial Volts.</i>
Carbon	35
Platinum	27
Iron	26
Nickel	26
Copper	23
Silver	15
Cadmium	10

The luminosity of an arc between two terminals is due partly to the vapor and partly to the incandescence of the terminals when these are of a nature to be raised to the necessary temperature.

The Carbon Arc. In the carbon arc the vapor itself gives out very little visible radiation, practically all of the light coming from the incandescence of the positive terminal in d. c. lamps or from both terminals in a. c. lamps. Fig. 158 represents the appearance of pairs of carbons with the arcs

between terminals for a. c. and d. c. open and for the enclosed lamps. In the d. c. lamp the positive carbon contains at the end a crater formed by the rapid volatilization of the material at this point which is the hottest region about the arc. The

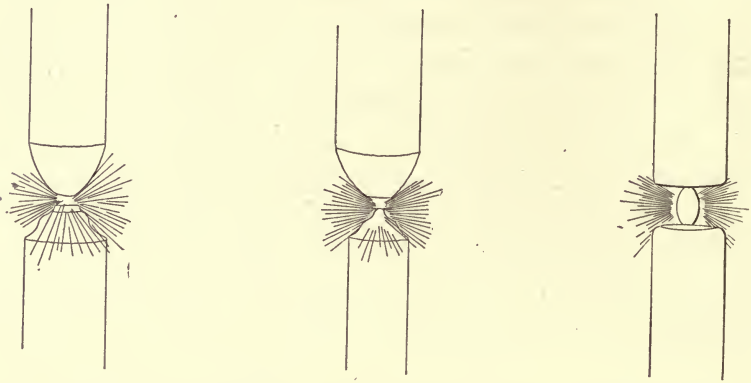

FIG. 158. Appearance of the d. c. and a. c. open arcs and of the enclosed arc.

temperature of the crater is estimated at from 3500 to 4000° C. and it emits about 85 per cent of the total light. The arc itself furnishes perhaps 5 per cent and the remainder comes from the tip of the negative carbon. In the alternating current arc the light comes from both tips, a very small quantity being given off by the arc. The condition is the same in the enclosed arc although here the carbons are separated by a greater distance than in the open forms.

The manner in which the light is radiated by the characteristic carbon arcs is shown in Fig. 159. The crater of the positive terminal of the d. c. arc, which is usually above, acts as a natural reflector, throwing the light downward. The alternating arc requires a reflector to render the upper light zone available. In projection lanterns, which are preferably equipped with d. c. arcs, the crater may be formed in a vertical

position by inclining the carbons or by setting the negative somewhat in front of the positive tip. The light is then efficiently directed toward the condensing lens.

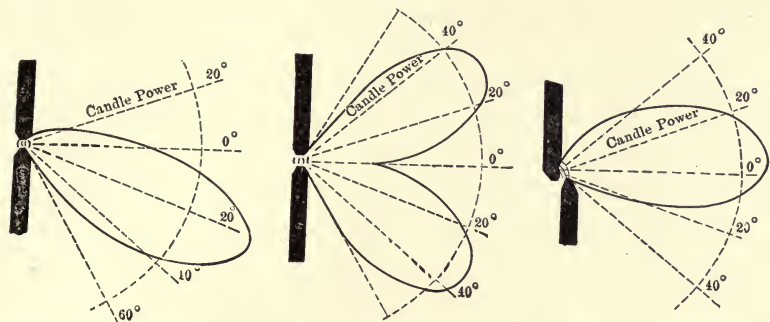

FIG. 159. Diagram of distribution of light from d. c. and a. c. arcs.

New Forms of Arc. The standard carbon arc lamps produce their light by the incandescence of the carbon terminals, practically no light being given out from the arc itself. The most successful improvements in arc lamps have been those by which the arc itself has been made luminous. In the Bremer and Blondel lamps, materials such as calcium and strontium are added to the carbon resulting in the production of very luminous and highly efficient arcs. From the appearance of the arc these lamps are known as "flaming arc lamps." In these lamps the carbons produce between the terminals a vapor path which acts as the vehicle to convey the particles of the light-producing substances. The presence of these substances in the arc reduces the temperature of the terminals so that comparatively little light comes from the heated carbon tips. The efficiency of light production by these lamps is nearly ten times as great as that of the carbon arc and nearly thirty times as great as that of the ordinary carbon filament incandescent lamp.

Flaming arc lamps are best adapted to the lighting of large

spaces as the light is produced at very high candle power. The fumes given off by the lamps are objectionable in confined spaces, hence good ventilation must be provided. The color of the light, while more or less under control, is not as satisfactory as that of incandescent lamps.

The Magnetite Arc Lamp. A very successful form of flaming arc lamp, which is being adopted for street lighting, is one in which the one terminal is copper and the other magnetite. A bluish light is produced at high efficiency and the consumption of metal in the arc is so slow that trimming need only be done at long intervals.

Construction of Arc Lamps. In order to produce and maintain the arc in an arc lamp several devices are necessary. The terminals must first be placed in contact, then drawn apart the desired distance. This distance must be maintained as the carbons burn off. The lamp must be cut out of circuit if for any reason the regulating device fails to act. The construction of the lamps depends upon the variety of circuit upon which they are to operate. A circuit especially designed for arc lighting alone is usually a series circuit, as it is easy to maintain a constant current in such a circuit and constant current is best for the arc. In many cases it is desirable to operate arc lamps in multiple on a constant potential circuit. There are, therefore, *series* or constant current lamps and *multiple* or constant potential lamps. Either type may be adapted to direct or alternating current.

The regulating mechanism of the series lamp is for the purpose of maintaining the predetermined distance or e. m. f. between the terminals, when a constant current is supplied. The regulating mechanism consists of springs and of solenoids in series and in shunt with the arc. The arrangement of coils gives rise to two general types of lamp, the *differential* and

the *shunt*. In the former, the series coils are used for raising and the shunt coils for lowering the carbons. As shown in Fig. 4, the coils act upon hinged armatures which control the clutch, which in turn engages a long rod carrying the upper carbon. The series coil carries the main current and tends, when energized, to cause the clutch to grip the rod and raise it. The shunt coil which is connected across the arc tends to release the clutch and allow the rod to descend, shortening the arc. The operation of a differential lamp is as follows: When no current is flowing the carbons are in contact. As soon as current begins to flow the series coil comes into action, pulling the carbons apart. The arc is thus formed and the current gradually burns off the carbons. As soon as the arc becomes long enough to energize the shunt coil sufficiently the latter allows the upper carbon to descend. The arc is thus maintained at a uniform length under the differential action of the two coils. If by any accident to the mechanism the arc becomes too long, an automatic "cut-out" short-circuits the lamp and prevents excessive voltage across the terminals of the shunt coil.

In the shunt lamp there is no series coil, its place being taken by a spring which serves a similar purpose. When there is no current in the lamps the carbons are in the position occupied when current was cut off, as the spring pulls continuously, clamping the clutch until the shunt coil is energized. When the current is turned on the carbons are fed together, and when they touch the shunt coil is short-circuited and the spring pulls the carbons apart. As the arc lengthens the drop in e. m. f. increases until the shunt coil overpowers the spring and the clutch is loosened.

Multiple arc lamps are designed to operate on a constant voltage, hence the mechanism must be susceptible to change in current instead of arc voltage as in series lamps. A solenoid

in series with the arc takes the place of the shunt coils in series lamps, its function being to release the clutch when the current is reduced below a certain amount. The lengthening of the arc increases its resistance and hence cuts down the current. When not in operation the carbons are in contact and are drawn apart by the solenoid when e. m. f. is applied to the terminals. In series with the arc in all multiple lamps is a "ballast," of reactance in a. c. and resistance in d. c. lamps, for the purpose of steadying the current. The movement of the mechanism, even when resisted by a dash pot, is irregular unless ballast is used.

It is sometimes desirable to operate several multiple lamps in series, for example, on a 220 or 440 volt circuit. It is possible to do this on alternating current circuits by connecting the lamp junctions to taps in a single coil transformer so that the voltage will be evenly sub-divided among the lamps. In general the best satisfaction is obtained by avoiding such special arrangements.

Open and Enclosed Arcs. In addition to the regulating mechanism there are other important parts of the lamp. An enclosing globe surrounds the arc in most modern lamps for the purpose of keeping unnecessary oxygen away from it and thus increasing the life of the carbons by at least ten times. The globe is not air tight but the passages to the outside air are small, and circulation of the air is not encouraged. The enclosed arc is longer than the open, causing more drop in e. m. f. and producing a given power consumption with less current than in the open arc. While a certain amount of light is absorbed in the enclosing globe the resulting diffusion and improvement in illuminating efficiency offsets the loss. The saving in trimming is, however, the main advantage. An all-night open lamp requires two sets of 12-inch carbons each

of which will burn from 8 to 10 hours. The enclosed lamp will operate nearly 100 hours on one pair.

Light Produced by Arc Lamps. At one time arc lamps were rated in candle power, 1200 c. p., and 2000 c. p. lamps being standard. This rating was entirely nominal, as a 2000 c. p. was one in which 450 watts were consumed at the arc. The actual candle power in such lamps is much smaller than indicated by the rating. At the present time arc lamps are not rated in candle power but in current, e. m. f. and power consumption.

A certain electrical power used in an arc of a given kind will produce a definite quantity of light. Hence, as photometer measurements are difficult, and power measurements are easy to make, it is much better to avoid, for commercial purposes, any reference to candle power except in comparing the efficiency of various light sources.

The Vacuum Tube Lamp.

Fig. 5 shows the general arrangement of a modern vacuum tube lamp. A glass tube about 1.75 inches in diameter is used in such lengths as to produce the desired quantity of light. Carbon terminals are inserted in the ends of the tube and current is conducted between them by low pressure air or other gas within the tube. The high voltage required to maintain the current is produced in a raising transformer with its primary circuit connected to the regular service mains. The tube tends to further exhaust itself in action, and to prevent too great a decrease in pressure a regulating valve is provided. It consists of a glass tube containing a porous carbon plug ordinarily covered with mercury. Over the plug is a movable glass tube which contains at its upper end a bundle of iron wires. These form

the core of a solenoid connected in series with the primary of the transformer. When the core is drawn up by the solenoid the tip of the carbon plug is exposed and air (or other gas) is admitted to the tube. Up to a certain point the conductivity of the gas increases as the pressure diminishes, therefore more current is drawn from the line and through the solenoid as the vacuum tends to improve. The increase in current raises the core of the solenoid. If the vacuum were allowed to increase it would eventually produce a much higher resistance and unsteady operation would result.

The Mercury Vapor Lamp.

This lamp consists essentially of a glass tube, several feet in length, exhausted of air and connected to a reservoir of metallic mercury. The metallic mercury forms one electrode, the other being located at the end of the tube remote from the reservoir. The tube is mounted so that it may be tilted to allow a stream of metal to connect the two terminals and thus start the arc. When once started the arc is maintained by the volatilization of the mercury, the vapor of which fills the tube. A greenish light of high intensity and efficiency is thus produced. In some forms of lamp (see Fig. 6) a tilting magnet is placed in an overhead canopy and the action of the tube is entirely automatic, otherwise it is tilted by hand. This lamp, being of an electrolytic nature, is essentially a direct current lamp. The action consists in the vaporization of the mercury, the vapor rising, condensing on the tube and flowing back to the reservoir for re-evaporation.

Fields of Application of Electric Lamps.

Incandescent lamps are used for the illumination of residences, shops, offices, etc., for the lighting of large interiors and to a limited extent for street lighting. In spite of the

low efficiency the lamps are popular because they are cool, safe and convenient to operate, and the small size of the units permits uniform distribution of the light by the use of a large number of lamps. The color of the light is satisfactory, especially in the high temperature lamps of recent development. In large interiors where the construction of the building is such that the lamps may be located within a reasonable distance of the floor, incandescent lamps, distributed at an average rate of from 10 to 20 16 c. p. lamps per thousand square feet of floor area, produce a soft, uniform and efficient illumination. A similar allowance is satisfactory in residences. The allowance of light is one for which no general rules can be laid down, as the color of the walls, ceiling, and floor and the purpose for which the room is designed very largely affect it. All such lighting must be planned with both the general and special requirements in view. For example, a large shop may contain a number of machines at which fine work is done. Assembling processes may be going on in the same room. The former require special lighting. Each of the machines would be provided with one or more incandescent lamps in addition to the general lighting which might be either by incandescent or arc lamps.

Street lighting by standard incandescent lamps is not popular although practiced to a limited extent. While the small units are advantageous in giving good distribution of light in streets, the large number is objectionable. Further, incandescent lamps are essentially constant potential lamps, and operate best, therefore, in parallel. For copper economy, street lighting can be best accomplished by means of a series circuit with constant current, because it is cheaper to maintain the latter than a constant potential at the lamps. While series incandescent circuits are in operation they are on the whole more troublesome to operate than arc lamps for a given

amount of illumination, for several reasons, among which are the following: First, there are more of them. Second, the current is smaller and more circuits with their regulating mechanisms must be used. Third, they are much less efficient.

Nernst lamps are used both for street and for interior lighting. Their high efficiency commends them and the quality of light is excellent. They operate best on alternating current circuits and are always connected in multiple. They are most satisfactory on a higher e. m. f. than the standard forms of incandescent lamps.

Arc lamps are most suitable for street and other outdoor lighting. They are too bright for most interiors, although when softened by enclosing globes of opal or sanded glass the light is satisfactory for many purposes. Their high efficiency is best utilized when the arcs can be surrounded by clear globes, which is the case only in outdoor work. Flaming arcs, as a rule, must be enclosed in opal globes on account of their intensity. Their efficiency is great enough to offset the loss thus incurred.

Vacuum tube lamps are adapted only to indoor illumination. The light is soft and agreeable and of good color. The tubes, as at present constructed, are mainly designed for support from ceilings and walls. The efficiency of the lamps is not high enough to permit them to compete with the arc lamp for outdoor lighting.

Mercury vapor lamps are used for general illumination where the peculiar actinic values of the light are appreciated, and where the green color is not objectionable. By means of "artificial skylights" constructed of these lamps the photographer is independent of the sun in making exposures. The light is being found valuable in shops, wharves and warehouses.

Light and Illumination.

In the Introduction a general summary of the status of electric lighting is presented. The various commercial forms of electric lamp are briefly described. In all of these, light is produced inefficiently, for in any light-producing source the major portion of the power used is wasted in the form of heat, and at the best but a small part of the power appears in light. In the past few years new forms of gas and electric lamps have been developed and increased efficiency secured. The ordinary forms of electric lamp do not produce light cheaply but they are used because they are convenient, safe, cleanly and cool.

The following table* indicates the relative values of the

TABLE SHOWING RELATIVE COMMERCIAL VALUES OF
VARIOUS LIGHT SOURCES.

Source of Light.	Calories per candle per hour.	Cost per 1000 candle-hours, in cents.
Kerosene lamp	36.4	21.
Gasoline	16.3	22.
Welsbach incandescent gas light	11.0	6.8
High-pressure incandescent gas light	6.48	4.5
"Lucas light"	7.82	4.8
"Millenium light"	5.77	3.5
Carbon Filament electric lamp	2.6 to 3.99	30 to 46
Osmium lamp	1.34	16.
Nernst lamp	1.63	19.
Electric arc lamp	0.9	11.
Flame arc	0.2	2.3

various light sources now in use. Since the preparation of this table other forms of electric lamp have been invented. Of these the tungsten incandescent lamp promises most, and when

* Quoted in the Proc. of the International Electric Light Assoc. for 1905 from a paper by Wedding, before the Cologne Electrical Society.

commercially available will be on about even terms with the present form of carbon arc lamp.

In studying the subject of electric lighting a distinction must be made between the intensity of illumination in a light source and the amount of illumination which will be produced. The most efficient sources of light (the efficiency being measured for convenience in candle power per watt) do not necessarily produce the most efficient illumination for several reasons. First, these very efficient light sources are of large candle power and hence must be widely distributed. A few light sources, placed far apart, do not give the most satisfactory illumination under ordinary circumstances. Second, light produced at very high luminous intensity is more rapidly absorbed by the atmosphere, hence, proportionately less reaches the object to be illuminated. Third, the color of the light affects its value as an illuminant. These facts indicate the distinction which must be made between *light* and *illumination*. Illumination is the desired end of electric lighting and from this standpoint all light-producing devices must be judged.

Efficiency of Light Production.

The thermodynamic efficiency of light production is very difficult to determine as it depends upon the wave length of the radiation. All of the energy which is absorbed by a light producing source goes off in the form of radiations of various wave lengths. Unfortunately only a small part of these are visible. It would be very convenient if the ratio of energy radiated in visible wave lengths to the total energy absorbed had some definite value. Numerous tests have been made to determine this ratio and Dr. Roeber states that the best determination is that of Angström. Angström's determination indicates that if all of the energy radiated by a black body

appeared as light, one mean spherical candle power would be equivalent to 0.115 watt, or one watt to 8.7 mean spherical candle power. This gives a value for the particular quality of light experimented upon. It is not safe to apply the constant in general, as the efficiency varies greatly with the wave length. For practical purposes the efficiency is considered as a certain number of mean horizontal or mean spherical candle power per watt. Dr. Roeber estimates that the tantalum lamp which consumes about 2.8 watts per mean spherical candle power has a thermodynamic efficiency of 3 per cent as calculated from Angström's coefficient. A table published by Mr. E. P. Lewis gives useful comparative data regarding the luminous (or thermodynamic) efficiency of various light sources and the corresponding watts per candle power, the reciprocal of the commercial efficiency.

TABLE OF LUMINOUS EFFICIENCIES AND POWER CONSUMPTION IN VARIOUS LIGHT SOURCES.

Source.	Luminous Efficiency Per cent.	Watts per Candle power.
Red hot wire	0	...
Hydrogen flame	0	...
Candle	1-2	85
Oil lamp	2-3	57
Gas flame	2-3	68
Welsbach burner	3-5	...
Carbon filament	3-6	3-5
Nernst	5-7	1.2-2
Titanium	2.5
Osmium	7	1.7
Tantalum	1.9
Tungsten	1-2
Zirconium	1
Helion	1
Arc (carbon)	10-12	0.5-1.5
Arc (flaming)	12-15 or more	0.12-0.25
Mercury vapor tube	30-40	0.25-0.5
Vacuum tube	20-40	...
Sun	34	...

Units of Light and Illumination. A light source obviously produces a certain *quantity* of light at a definite *intensity*, although this intensity may not be the same in all directions. An incandescent lamp viewed in a plane perpendicular to its axis and passing through the middle of the filament loop will yield its maximum intensity. Through the tip about one-half this is delivered, and through the base practically none. A vacuum tube lamp produces a light of much lower intensity than the arc lamp, hence it is necessary to use a long tube of rather large diameter to produce the same quantity of light as would be produced in a very small space by the arc.

The standard of intensity and of quantity of illumination is the light from the hefner burner of specified dimensions, burning amyl acetate gas. Formerly a standard candle, consuming a certain quantity of wax per minute, was used for reference and from this practice the expression *candle power* has become firmly fixed in this country although the candle has long since been replaced by the hefner standard. The hefner unit is 88 per cent of the standard candle power. A hefner or a candle power is the intensity of illumination produced by one of these standards in a horizontal direction. If a standard candle gave out its maximum intensity in all directions the quantity of this light would be a spherical candle power. This is the standard of quantity in this country.* The intensity of illumination produced upon a surface one foot in a horizontal direction from a standard candle, is a candle-foot or foot-candle; upon other surfaces the intensity of illumination is inversely as the square of the distance from the light source. These surfaces are considered as normal to the direction of the light rays. In calculating the intensity of illumi-

* The French unit is the quantity produced by one hefner in a solid angle which subtends a square meter at a meter distance. It is called a *lumen*. The intensity of illumination produced by a lumen, at one meter distance from the source, is a *lux*. One spherical candle power is equal to $4\pi \div .88$ or 14.3 lumens.

nation at any point the effect of all contributing light sources must be added. Fig. 160 is an illumination chart plotted for a room and showing the intensity in all parts of a given level produced by light sources located as shown.

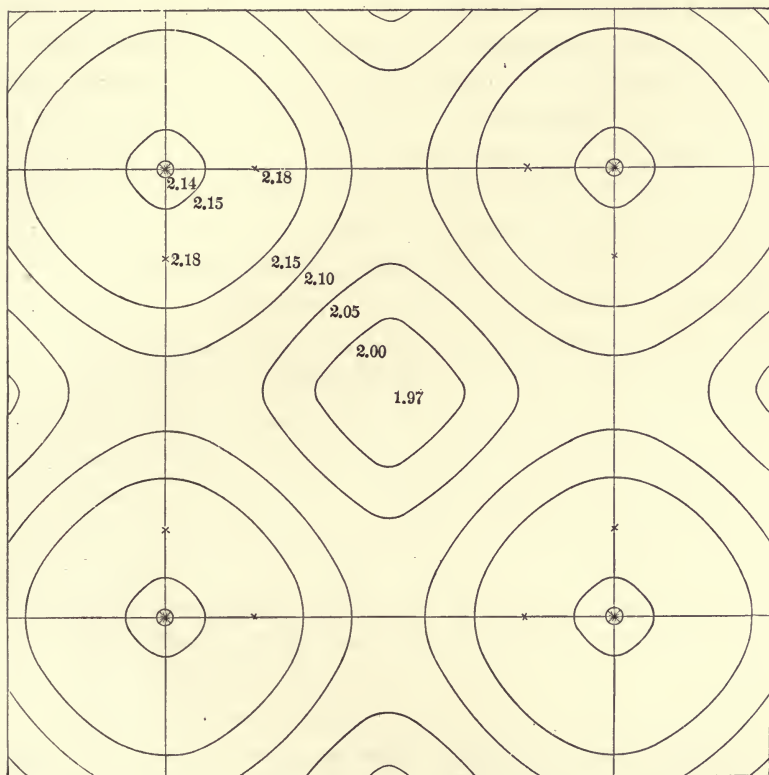

FIG. 160. Chart of illumination of room by four light sources at a plane 30 inches from floor. Figures indicate candle feet.

Electric Heating

Closely allied with electric lighting is the production of heat for cooking, room warming, and for metallurgical purposes. Electrically produced heat is convenient, cleanly and efficient as far as the transformation from the electric circuit is con-

cerned. The efficiency of this transformation is 100 per cent. For most purposes the electrical energy is too expensive to render heat production practicable by this means. For example, suppose that a cubic foot of water is to be raised to boiling temperature from 60° F. Assuming the weight of the water at 62.35 pounds the number of B. T. U. required is 9477. Each B. T. U. is equivalent to 778 foot-pounds and the total energy represented is 7,373,000. One k. w. hour is equivalent to 2,654,000 foot-pounds, hence to heat the water will require 2.77 k. w. hours. If the price of electrical energy is 10 cents per k. w. hour, an average figure for residence service, the cost will be 27.7 cents if all of the heat goes into the water and there is no radiation. A pound of coal worth a quarter cent, will produce 10,000 B. T. U., and if efficiently burned would produce the required heat. Even allowing as low an efficiency as 25 per cent for the combustion, the total cost of heating the water is but one cent. This illustrates the status of electric heating from the standpoint of expense.

In spite of the great cost, electric heat is used to an increasing extent. The heat is produced in all cases by the passage of the current through a high resistance. This may be in a wire of resistance alloy, in a liquid or fused solid or in carbon.

Applications of Electric Heating. *For cooking and room warming* the usual heater is a coil of wire of iron or of german silver or other alloy. If the temperature to be produced is very high the wire may be immersed in refractory material to exclude air and prevent oxidization. The coils are arranged to deliver the heat without loss to the body to be heated, as all radiation must be prevented to maintain a high efficiency. Electric cooking on a large scale is carried on at Niagara Falls where electric energy is cheap, and where the cleanliness and

convenience obtained compensate for the cost. Electric car warming is generally practiced in cities on account of the simplicity of operation. This practice is being discontinued in many instances and hot water warming substituted to obtain greater economy.

For welding, a most important application of electric heat, the resistance is produced by the imperfect contact of the two metal surfaces which are to be joined. When the welding temperature has been reached the surfaces are pressed firmly together and an excellent weld results. This method is used in the manufacture of wagon tires, bucket and barrel hoops, etc., and in attaching fish plates to rails in electric railway work.

For metallurgical purposes the heat due to the passage of a current between carbon terminals gives a source of very high temperature for melting refractory materials. In these electric furnaces the arc is surrounded by a fire clay and the heat is concentrated as desired. In the manufacture of aluminum a bath of fused cryolite is maintained at the necessary temperature by the flow of current against the resistance of the cryolite and the contact resistance between the carbon electrodes and the cryolite. In the carborundum furnace the resistance is contained in the carbon of the core.

For surgical work, platinum wires, heated by the current, are useful for cauterizing wounds and other similar purposes.

CHAPTER XII.

ELECTRICAL MEASUREMENTS.

Instruments for Measuring Current. — The electro-dynamometer with torsion control — The electro-dynamometer with gravity control — Portable electro-dynamometers — Shunts for electro-dynamometer ammeters — Permanent magnet ammeters — Movable magnet ammeters — Movable coil permanent magnet ammeters — Soft core ammeters.

Coil and plunger ammeters — Ammeters with rotating soft iron cores.

Instruments for Measuring Quantity.

Instruments for Measuring e. m. f. — Electrostatic voltmeters — High resistance ammeter voltmeters — Hot wire voltmeters.

Instruments for Measuring Power.

Instruments for Measuring Energy. — Commutator motor meters — Induction motor meters.

Special Instruments. — Frequency indicators — Power factor indicators.

ELECTRICAL instruments are required for a number of different purposes in connection with an electrical plant. (1) Upon the consumer's premises an energy or a quantity meter must be installed to indicate the monthly consumption. (2) Similar meters are required in the power plant to measure the total amount of energy generated. (3) In the power plant ammeters, voltmeters, wattmeters, etc., are needed for the proper disposition of the load among the machines. (4) Standard instruments are necessary for checking or calibrating the operating instruments.

The important electrical quantities of which measurement is necessary are: (1) current, (2) quantity, (3) e. m. f., (4) power, (5) energy, (6) frequency, and (7) power factor.

Instruments for Measuring Current.

The instruments used for the measurement of direct and alternating current may be divided roughly into three general classes:

1. Those using the mechanical reaction between two coils carrying current as the source of the deflecting force. These instruments are equally applicable to either direct or alternating currents but are particularly well adapted for the latter. Such instruments are known as *electro-dynamometers*.

2. Those using the mechanical reaction between a permanent magnet and a coil carrying current, either the coil or the magnet being movable. As the field of the permanent magnet is fixed, this class of instrument is only useful for measuring direct currents.

3. Those employing a coil carrying current and a soft iron core, forming a combination which can be used either for direct or alternating current measurements.

The Electro-Dynamometer with Torsion Control. The electro-dynamometer, when constructed for the measurement of current, is made up of two coils connected in series, one being fixed and the other movable. The movable coil, which usually is wound with the smaller number of turns, surrounds the fixed coil and rotates about its axis. In the normal or zero position, the plane of the movable coil is perpendicular to that of the fixed coil. The current is carried into the movable coil through mercury cups into which the terminals dip. When current is passed through the two coils in series the mechanical reaction of one on the other tends to rotate the movable coil into the plane of the fixed coil, this tendency being resisted by a spring, the function of which is to restore the movable coil to its original position. The spring is attached at its upper end to a torsion head arranged with pointer and scale so that

the amount of twist given to the spring to produce the force necessary to restore the movable coil to its original position can be readily measured. Fig. 161 shows a convenient and popular form of electro-dynamometer.

In this instrument when equilibrium has been established by twisting the torsion head, with the movable coil in a plane

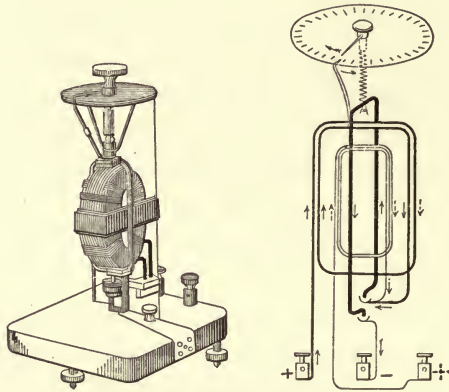

FIG. 161. View and diagram of the Siemens's electro-dynamometer.

normal to that of the fixed coil, there are two rotative forces balanced against each other:

1. The deflecting force due to the current and proportional to its square, the force being produced by the same current in both coils.
2. The restoring force due to the twisting of the spring through an angle which is directly proportional to the force produced.

From (1) and (2) it follows that the current, as measured by the angle of torsion of the spring, is proportional to the square root of that angle, or that the angle of torsion is proportional to the square of the current.

If ω is the angle of torsional deflection, and k is a constant, the torsional deflection due to one unit of direct current and

obtained by comparison with a direct current standard such as a silver voltameter, then

$$I = k\omega^{\frac{1}{2}}.$$

When calibrated by means of a direct current, as all alternating current instruments must be fundamentally, the electro-dynamometer is correct without further adjustment for use as an alternating current instrument, as is evident from a consideration of the following facts:

1. The direction of the rotative tendency of the movable coil is independent of the direction of the current in the coils because the current reverses direction in both at the same time.

2. The turning moment of the movable coil is proportional to the square of the current.

The movable coil, through its property of inertia, mechanically integrates the impulses received from the alternating current, and hence averages the square of the instantaneous values of the current so that the square root of the deflecting force necessary to hold the movable coil in its zero position is proportional to the effective value of the current, which is, by definition, the square root of the mean of the squares of the instantaneous values.

Summary: *The electro-dynamometer may be used for the determination of the effective value of an alternating current of any wave form when it has been calibrated by reference to a direct current standard.*

The Electro-Dynamometer with Gravity Control. Another instrument utilizing the general principle of the interaction of two currents or of the same current on itself, is known as the Kelvin (or Thomson) balance. (See Fig. 162.) No torsion is used in this case, but the attraction which results from the

tendency of two coils in parallel planes to shorten the length of the magnetic circuit about them is utilized, and this attraction is weighed. The scale arm is calibrated so that the placing of a weight at a particular place indicates a certain current. As gravity alone is depended upon to supply the restorative force there can be no deterioration in this type of instrument after calibration and it is therefore a great favorite in standardization laboratories. It is not portable and hence is not a commercial form of instrument.

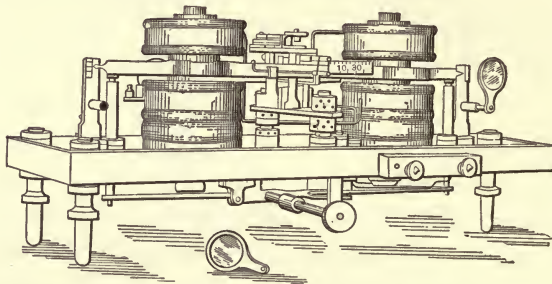

FIG. 162. The Kelvin current balance.

Portable Electro-Dynamometers. When the electro-dynamometer principle is to be used in producing an ammeter of portable form, the torsion head is not ordinarily used, but the movable coil is allowed to deflect against the resistance of coiled springs and a direct reading instrument is thus produced. The deflections bear no definite relation to the current, for the relative positions of the two coils, movable and fixed, are changed as soon as the slightest deflection is made. The current is supplied to the movable coil through the control springs as the mercury contacts cannot be used in a portable instrument. These instruments are calibrated over the entire length of the scale instead of being standardized by the determination of one constant. After calibration they keep their accuracy for a long time, the only parts subject to deterioration

being the springs and the bearings. A number of satisfactory commercial forms of alternating current ammeter using the electro-dynamometer principle are upon the market.

Shunts for Electro-Dynamometer Ammeters. It is evident that the springs of a portable dynamometer-type ammeter cannot be made large enough to carry anything but the smallest currents and at the same time have sufficient flexibility to render the control sufficiently sensitive. To avoid this difficulty it is customary to send but a part of the current through the movable coil, the major part being allowed to pass through a resistance so adjusted as to deflect or "shunt" the desired proportion through the movable coil. This resistance is often and properly called the "shunt." The greatest care is taken in selecting the material of the deflecting resistance or shunt so that the temperature change due to variation of the current will not alter the resistance seriously. Metal with a temperature coefficient made low as possible is used. Fig. 163

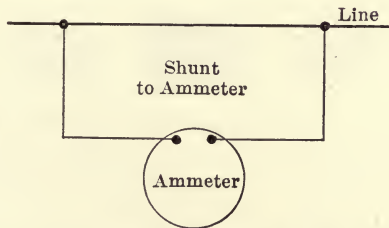

FIG. 163. Diagram showing the principle of the ammeter "shunt."

shows the shunt principle which is a useful one in many kinds of electrical measurements. If the measuring instrument, having a resistance R , is connected to two points between which there is a resistance r , the current will divide in the proportion $\frac{R}{r}$. The exactness of this division depends upon several factors.

1. The equality of temperature coefficients of shunt and instrument. If the resistance of the shunt increases more or less than that of the instrument with a given rise in temperature, the division of current will be proportionately changed.

2. The resistance of the contacts between the shunt and the instrument leads. This resistance is made low by careful construction, and the instrument is calibrated in connection with the leads which are to be used with it. The resistance of leads and contacts is made as small as possible in proportion to that of the instrument.

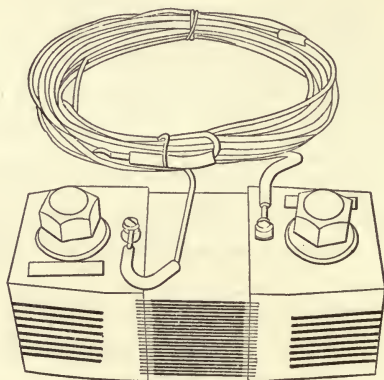

FIG. 164. A commercial form of ammeter shunt.

In Fig. 164 is shown a commercial form of instrument shunt. Several shunts may be used with the same instrument and its range may thus be greatly increased. One ammeter may be used in this way with currents varying from a fraction of one ampere to several thousand amperes.

Permanent Magnet Ammeters. One of the earliest forms of ammeter was that employing the reaction of a current on a permanent magnetic field as the source of a deflecting force bearing some relation to the current. Either the coil or the permanent magnet may be movable, and the choice of one or

the other plan leads to an instrument of marked characteristic properties, each type having its own inherent advantages.

Movable Magnet Ammeters. A small but highly magnetized bar magnet is very sensitive to the influence of the magnetic field produced by a current flowing through a coil. A short, wide magnet of lozenge form, pivoted in the center of a cylindrical coil with wire so disposed as to concentrate a strong field at its center, is a combination which produces fairly uniform deflections over a considerable part of the scale. The magnet is usually spring-controlled and the direction of the field at the zero position of a pointer attached to the magnet is perpendicular to the axis of the coil. The action of current in the coil is to draw the magnet toward the axis of the coil.

The instrument just described is an outgrowth of the familiar tangent and sine galvanometers which are accurate for the absolute determination of the value of a current. In these galvanometers the proportions of coil and magnet are such that the latter is subjected to certain determinable forces under the action of currents. In order to obtain reasonable accuracy the construction is such as to debar the galvanometers from the portable or even the semi-portable class.

Among the good qualities of the movable magnet ammeter may be mentioned the following:

1. *Sensitiveness.* As no current is carried through the control springs there is no need to make these larger than is necessary for control of the moving system. The deflecting force may be made as large as is desirable by increasing the number of turns, and thus the magneto-motive force, of the fixed coil.

2. *Simplicity.* As there are few and cheap parts the cost of instruments of this class can be kept low.

The limited popularity of instruments of the type described

is largely due to the tendency of the bar magnet to lose its magneto-motive force. This defect offsets its numerous inherent advantages over more complicated instruments. The needle is subjected to large counter magneto-motive forces from the coil, which tend in time to weaken that of the movable magnet, and hence frequent calibration of the instrument is necessary. As ammeters are in circuit constantly this counter magneto-motive force is always acting. A second point is that, on account of the inertia of the system, the vibrations of the moving parts render difficult the reading of the deflections, especially when the current varies greatly as is the case in many classes of work.

Movable Coil, Permanent Magnet Ammeters. The D'Arsonval galvanometer is the simplest form of instrument in which a coil is deflected by the current in a permanent magnetic field. The instrument, as adapted to commercial conditions, is shown in Fig. 165, and consists of a permanent bar magnet of U-form

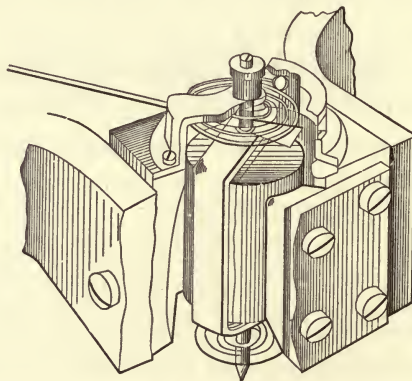

FIG. 165. Section of the principal parts of the Weston ammeter, a modified D'Arsonval galvanometer.

embracing between its poles a fixed cylindrical core of soft iron. The space between the poles and the core is just sufficient to allow a thin coil, which surrounds the core, to move freely.

In the laboratory form the coil is suspended vertically with its plane coinciding with that of the permanent magnet, by means of wires which control its position and at the same time conduct the current to and from the coil. The galvanometer is very sensitive and has the important property of damping the inertia vibrations by means of the eddy currents generated in the poles and the core. The permanent magnet is so large that its magneto-motive force is not seriously affected by that of the coil. This fact, combined with the artificial "aging" of the permanent magnet as now practiced by instrument makers, gives a very satisfactory degree of permanence to the magnetic field.

The commercial forms of the D'Arsonval galvanometer are modified in order to make the instrument portable. The torsional control is replaced by spring control, the support of

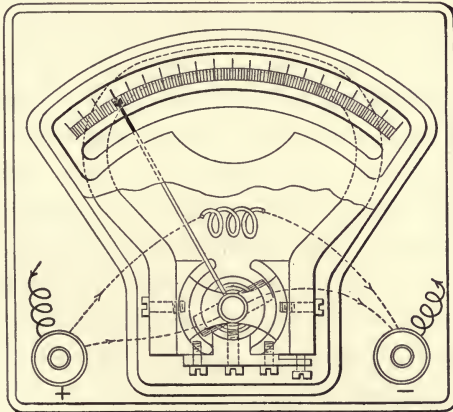

Fig. 166. View of the Weston ammeter, showing shunt enclosed within the instrument.

the movable coil being provided by jewelled pivot bearings. For convenience in placing the control magnet the axis of the coil is placed perpendicular to the plane of the magnet.

In addition to the advantages already cited, should be mentioned the uniformity of the deflections which are directly

proportional to the current in the commercial instrument. They have what is known as a "straight line law." The property of damping out the vibrations of the coil is increased by surrounding it with a copper cylinder, in which much larger eddy currents are generated than in the comparatively high resistance poles and core. The instrument shown in Fig. 166 is a modern commercial form of ammeter using the principle of the D'Arsonval galvanometer. As in the case of the electro-dynamometer ammeter, but a small part of the current can be sent through the movable coil. The deflecting resistance is placed in the same case with the instrument, where the current to be measured is small, but for very large currents it is placed in any convenient locality on the switchboard, while the instrument proper is connected with it by means of small wires. As these wires form part of the shunt circuit their resistance must be considered in calibrating the instrument.

Soft Core Ammeters. The mechanical reaction between a current and a mass of magnetic material is utilized in a variety of ways in ammeter construction. An instrument based on this principle can be used for either alternating or direct current measurement. The underlying principle of this form of ammeter is that the various parts of a magnetic circuit tend to arrange themselves so that the reluctance of the circuit shall be a minimum, which follows naturally from the inherent tension of the magnetic field. The application of the principle leads to the development of apparently radically different types of commercial ammeter, but the same fundamental facts apply to all. These types may be classed under two general heads:

1. Those in which the core is drawn into a cylindrical coil.
2. Those in which the core is placed eccentric with the coil, the two axes being in the same line.

Coil and Plunger Ammeters. The simplest possible form of ammeter and one of the earliest is that in which a soft iron plunger is drawn into a coil. The heating of the core by eddy currents is minimized by making it of a bundle of fine wires, and the hysteresis loss is made as small as possible by using the best material. The core and coil are so related that the deflections are as nearly proportional to the current as possible. There is the least reluctance in the magnetic circuit of this combination when the plunger or core is symmetrically located with respect to the coil, but the force drawing it into the coil is very small as this position is approached. It is also small when the core is far from this position. There is, therefore, a certain range over which the deflections per unit of current are maximum, and it is in this region that the instrument is useful. The best instruments of this type use gravity control. This is permanent and for many purposes convenient. Practically all of the coil and plunger ammeters are switchboard instruments and they are not portable, as the gravity control necessitates careful levelling.

Various plans have been introduced for making the core and plunger ammeter portable, the simplest being the substitution of springs for the gravity control. This type has, however, been largely superseded by other forms even for switchboard use.

Ammeters with Rotating Soft Iron Cores. The coil and plunger type of ammeter is accurate and inexpensive, but it lacks portability. In order to combine all of these desirable features various rotating core instruments have been devised, employing the same general principle as that of all soft core instruments, that is, the reduction of the reluctance of the magnetic circuit. A piece of soft iron located within and movable with respect to a solenoid will tend to take a position in which the total reluctance of the magnetic circuit is mini-

imum. An illustration of this principle is shown in Fig. 167. The current-carrying coil is inclined to the axis of rotation of a thin, flat, soft iron core. At the zero position of the pointer

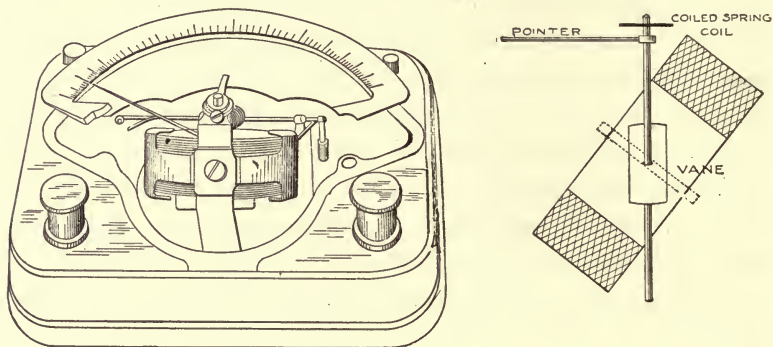

Fig. 167. View of the Thomson inclined coil, soft core ammeter.

the core, which is also inclined to its axis, lies approximately in the plane of the coil. This is the position in which its reluctance is maximum. The relative positions of core and coil are so arranged that when the pointer has reached the limit of the scale the core lies approximately in the axis of the coil, in which position it improves the reluctance of the circuit to the maximum extent. The deflections per ampere in this instrument are not uniform, but are proportionately large near the center of the scale.

Instruments for Measuring Quantity.

By definition, electrical quantity is the product of current and time, that is, it is proportional to the average current and to its duration. Any instrument, the action of which is proportional to the current and which allows the result of this action to accumulate, will prove a satisfactory quantity meas-

uring device. For example, the electrolytic effect of the current fulfills the requirements mentioned. The rate of electrolytic action is proportional to the current, and if the material deposited at the cathode be collected and weighed it will give a quantity proportional to the product of the average current and the time. This form of meter was in extensive use for measuring the quantity of electricity furnished for incandescent lighting purposes at constant pressure and with direct current until it was displaced by the more convenient devices now in use.

A combination of anode, cathode and electrolyte arranged for measuring purposes is known as a voltameter. This in one form, the silver voltameter, is referred to in the definition of the unit of current. The anode is of the metal which is to be deposited, and the cathode is preferably of platinum for calibrating purposes on account of the absence of oxidization and of the ease of cleaning. The electrolyte may be of a solution of almost any salt of the metal to be deposited, but it is found that for silver the nitrate is preferred, while the sulphates are best when depositing copper and zinc.

Although the voltameter is not in common use at the present time for commercial measurements, it still remains the most convenient means for the calibration of direct reading instruments. Ammeters can be calibrated by obtaining an average of deflections over an extended period, at least a half-hour, and comparing this with the average current indicated by dividing the total amount of metal deposited in the voltameter, by the time and by a constant, the weight deposited by unit quantity of electricity. The rate of deposition of metals corresponding to a given current is very constant with standard conditions of current density, temperature of solution and of method of manipulation. Silver, copper and zinc are useful for calibrating

purposes, the first named being the most reliable and most easily handled.

The electric motor, in one form or another, lends itself readily to quantity measurement. The armature of the motor, when operating in a magnetic field of constant strength is subjected to a turning force which is proportional to the current. By means of a magnetic or mechanical brake the speed of rotation of the armature is made directly proportional to the current and the total number of revolutions is a measure of the quantity. Coulomb-meters are not in general use in this country, as energy meters are considered preferable for all practical purposes.

Instruments for Measuring e. m. f.

In general there are two principles employed in e. m. f. measuring instruments. The first is the mechanical attraction between electrically charged bodies, and instruments employing these attractions are known as electrostatic instruments. The other class of voltmeters are simply ammeters of very high resistance and having auxiliary resistance so that the current drawn from the circuit will be negligible in amount.

Electrostatic Voltmeters. These operate like a quadrant electrometer except that they are arranged mechanically so that a deflection will be produced without the rotation of the torsion head usually employed in laboratory apparatus. An example of such an instrument is shown in Fig. 168. This is a ground detector arranged for permanent connection between the two wires and the ground to indicate the presence of a "ground" on the line. The scale is calibrated to read in volts as an indication of the severity of the ground. A full deflection of the pointer indicates a ground of fairly low resistance, while a partial deflection is evidence of a very high

resistance between the wire and the ground. The ground detector is the principal application of the electrostatic voltmeter in commercial practice in this country. As shown in, Fig. 168, the instrument consists of four pairs of metal quadrants, the lower two of which are connected together and

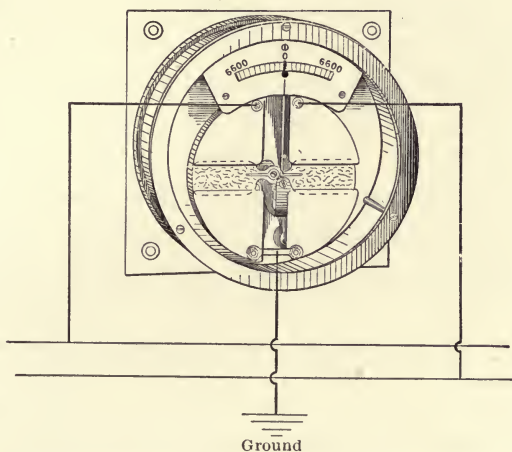

FIG. 168. The electrostatic voltmeter arranged as a ground detector.

grounded. Each of the upper pairs is connected to one line wire, either direct or through a high resistance. When a ground occurs there exists a difference of potential between the normally grounded quadrants and the quadrant connected to the ungrounded line wire. The vane tends to take a position in which the capacity of the instrument is maximum, which is when the vane is directly under the quadrants. In the single-vane form of instrument described, the electrostatic voltmeter is adapted only to very high pressures, from 1000 volts upward. It operates equally well on alternating and direct current. When it is desired to use the electrostatic principle in low voltage instruments a number of vanes

and sets of quadrants must be employed. The resulting instrument is known as a multi-cellular electrostatic voltmeter.

High Resistance Ammeter Voltmeters. Any one of the instruments described as an ammeter will be equally satisfactory as a voltmeter when the resistance is made sufficiently high so that only a small amount of current is drawn from the line. This resistance is partly in the instrument windings and partly in a series resistance winding located either inside or outside the case. When located outside the case the resistance is known as a *multiplier*. Usually these voltmeters are arranged with several resistances so that one deflecting part may be used on two or more voltages. For example, one standard form of instrument may be used on 15 volts, 150 volts, or 600 volts. Standard voltmeters may be purchased for any range and for several combinations of range in the same case.

The resistance of voltmeters should be as high as possible in order that they may remain cool when connected continuously in circuit and that the amount of power absorbed may not be sufficient to produce a serious loss. A 600-volt voltmeter may have a resistance as high as 75,000 ohms, a 150-volt voltmeter 16,000 and other ranges in proportion. With this amount of resistance the current drawn is not appreciable. The indicating instruments described for measuring current in combination with shunts are essentially voltmeters as they draw a very small proportion of the line current, the major proportion flowing through the shunt. The instrument is usually known as a *milli-voltmeter* and it is useful for many purposes. When connected across a shunt it gives a reading proportional to the current in the line. When connected in series with a resistance it may be used as a high reading voltmeter. In practice the indicating parts of voltmeters and ammeters are substantially the same.

Hot Wire Instruments.

The expansion of a wire when heated by the passage of a current is utilized in some instruments for measuring current. At one time voltmeters employing this principle were very generally used for alternating current work but they have been largely superseded by the ones described. The expansion of the wires causes a certain amount of slack which is taken up by a spring. The motion of this spring is transmitted to an indicating pointer through a small drum over which a cord passes. In some ways the hot wire voltmeter is a desirable instrument. There is no reactance because the wire is not formed into coils. It is not sensitive to rapid fluctuations in the current and hence gives a steady deflection. Instruments with this quality are frequently called "dead beat."

Instruments for Measuring Power.

The wattmeter is obviously an instrument in which the deflection is proportional both to the current and the e. m. f. The electro-dynamometer is the best form of instrument for measuring power. If the current in the movable coil is made proportional to the e. m. f. by inserting a large resistance in series with it and connecting it across the line, and, if the fixed coils carry the line current, the angle of torsion of the torsion head will be proportional to the product of the current and e. m. f. This form of instrument is not practicable for commercial use and as in the case of the ammeter electro-dynamometer, the moving coil deflects against the resistance of a spring, the scale being calibrated by reference to a standard.

Any other form of instrument in which the field can be made proportional to the current and the current which reacts against this is proportional to the e. m. f. will be a satisfactory wattmeter.

Instruments for Measuring Energy.

By far the most important of all instruments for practical commercial use are those which are used for measuring energy. These are placed upon the premises of all customers, and bills are based upon the readings. Energy meters are also placed on switchboards in power stations for the purpose of metering the total amount of energy generated so that an estimate of its cost may be made. Practically all energy meters (or watt-hour meters as they are called) are forms of electric motor adapted to the variety of energy to be measured. For direct current purposes the commutator motor is mostly used, and this is also well adapted to the measurement of alternating current energy. Usually for the latter a small form of induction motor is used on account of its greater simplicity.

Commutator Motor Meters. The standard form of commutator motor meter is shown in Fig. 169. The field is produced by the coils C which are connected in series with the line. The field is maintained perfectly uniform by the use of two coils separated by a small space which serves also to admit the axle of the moving part. The armature A , connected in series with the resistance R_2 across the line, carries a current which is proportional to the e. m. f. This armature is wound upon a light non-magnetic form to avoid inductance so that it may be used either with direct or alternating currents. The armature is mounted upon the axle S , and the current passes through a commutator as in all direct current motors, the commutator in this case being made of silver to prevent oxidation. The extra winding R_1 is placed around the armature and is connected in series with it for the purpose of producing a weak field sufficient to overcome the effect of friction. The motion of the armature is resisted by an electro-magnetic brake located at the bottom of the case. Perma-

nent magnets MM produce a magnetic field in which rotates a copper disk D . As the disk cuts the magnetic field it generates eddy currents which resist its motion. By proper adjustment of the position of the magnets the velocity of the armature may be made practically proportional to the power in the line. The axle of the armature is supported in jewel

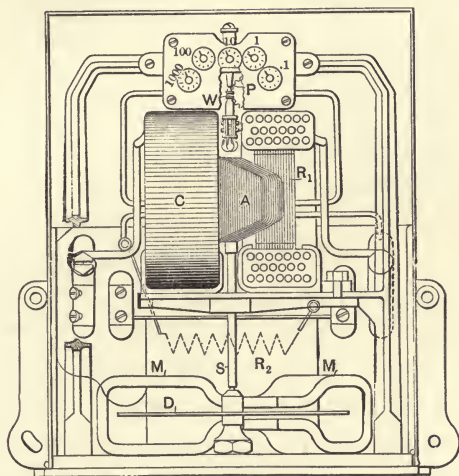

FIG. 169. The Thomson watt-hour meter for direct and alternating current circuits.

bearings PP , hollowed out to admit the conical ends of the axle. The revolutions of the armature are recorded by means of a worm gear W upon a train of dials. The scales of these dials are adjusted to suit the range of power expected in the circuit. Ordinarily one complete revolution of the right hand dial corresponds to 10 k. w. hours or to 1 k. w. hour. In the figure, one revolution of the right hand dial corresponds to one k. w. hour.

Induction Motor Meters. For alternating current work a special form of single-phase induction motor may be employed. The rotating part is a disk or shell of metal, preferably

aluminum. The rotating field is produced by two coils, one of which carries the line current and the other a current proportional to the e. m. f. These coils are displaced from each other by an angle, say 45° , and the phase position of the current is also displaced by windings of different reactances. That is, if one coil has largely resistance and the other largely reactance they will carry currents differing by an angle between zero and 90° , say 45° . The combination of these currents produces a rotating field which induces eddy currents in the moving part. The braking devices and the recording mechanism are the same as in the commutator motor already described.

Special Instruments.

In station practice it is desirable to have upon the switchboards instruments which will indicate the frequency and power factor of the current. The general principle of such instruments is that of the production of a rotating field by means of two mechanically displaced coils carrying electrically displaced currents. This principle may be illustrated by reference to a typical frequency meter. Suppose that the induction motor energy meter described above had its moving part restrained by a spring. If a pointer be attached to the axle and allowed to move over a scale it will indicate the force with which the axle tends to revolve. The degree to which the field will tend to rotate will depend upon the phase displacement of the currents in the two coils. If the winding of one coil be made of high resistance and the other of large inductance, the phase displacement of the currents will depend upon the frequency. If the frequency be zero the two currents will be in phase. As the frequency increases the reactance of the inductive circuit increases and its current lags farther behind the e. m. f. In the resistance circuit the cur-

rent is always in phase with the e. m. f. Thus as the frequency increases there is a stronger rotating field which produces increased torque upon the movable secondary and deflects it farther. The scale when properly calibrated will indicate the frequency of the current in the circuit.

The power factor indicator contains two windings, one connected in series, the other in parallel with the line. In one form of instrument for polyphase circuits the windings are connected as those of the primary of an induction motor. Each winding produces a rotating field, and the torque is zero when the current and e. m. f. are in phase, that is, when the power factor is unity. As the phase position of the current and e. m. f. are displaced, a torque bearing a definite relation to the phase displacement is produced.

CHAPTER XIII.

THE TRANSMISSION OF INTELLIGENCE.

OUTLINE.

Telegraphy: Simplex — Duplex — Quadruplex — Receiving and Printing Devices — Automatic Systems — Wireless Telegraphy.

Telephony: The Transmitter — The Receiver — The Ringer — The Subscriber's Station — The Central Office — Distributing Circuits — Wireless Telephony.

As suggested in the introduction, it is possible to transmit signals or speech to a great distance by means of the electric current. At the present time the telegraph is worked over distances greater than three thousand miles, and the telephone over distances greater than one thousand miles. Intelligence may be transmitted by:

- (a) Telegraphy, with or without wires.
- (b) Telephony, with and without wires.
- (c) Combinations of telegraphy and telephony.

Telegraphy.

Simplex Telegraphy, used on lines over which the number of messages to be transmitted is not very great, has been briefly described on page 12. Messages are transmitted in this system by depressing a key, and thereby closing an electric circuit for intervals of greater or less duration. The short interval is termed a "dot" and the long interval a "dash," the latter being about three times as long as the former. Combinations of dots and dashes produce the letters of the alphabet, in accordance with a code designed by Professor Morse and known therefore as the Morse alphabet.

This alphabet is the one in general use in this country for land telegraphy, and it is also used in modified form for ocean telegraphy.

In the closed circuit system illustrated in Fig. 10, page 12, the keys and relays are connected in series with the line, each key being normally short-circuited by a switch when not in use. When the operator desires to use the line, the key switch is opened, and signals are produced by means of the lever, which makes and breaks a contact. The relays are of high resistance due to the many turns of fine wire with which they are wound so that the amount of current required on the line is not great. A relay resistance of 150 ohms or higher is not unusual. In the closed circuit system all of the relays on the circuit operate at the same time, and the lines can be used for the transmission of a message by but one operator at a time, hence the name *simplex*. The current necessary for the operation of the relays on a simplex line is supplied by storage battery or electrical generators located at the terminal stations, which are usually in large cities. On account of insulation and other difficulties, it is impracticable to use an e. m. f. greater than 200 volts for simplex lines, and this only in the case of circuits several hundred miles in length.

The receiving instruments are furnished with current from a local primary battery, or in very large offices from a storage battery or generator. The receiving instrument is usually a sounder, as illustrated in Fig. 10, page 12. The receiving operator takes the message from the sounder by ear and transcribes it either by hand or by typewriter.

For special purposes where a record direct from the instrument is desired, some kind of a writing or printing instrument is used. The earliest practical form of telegraph receiver was the one developed by Morse in which a paper tape is drawn under a stylus, carried by the end of the armature lever of

the sounder. The paper is moved by a clock-work mechanism, and the stylus indents the paper with dashes or dots corresponding to the duration of the current in the circuit.

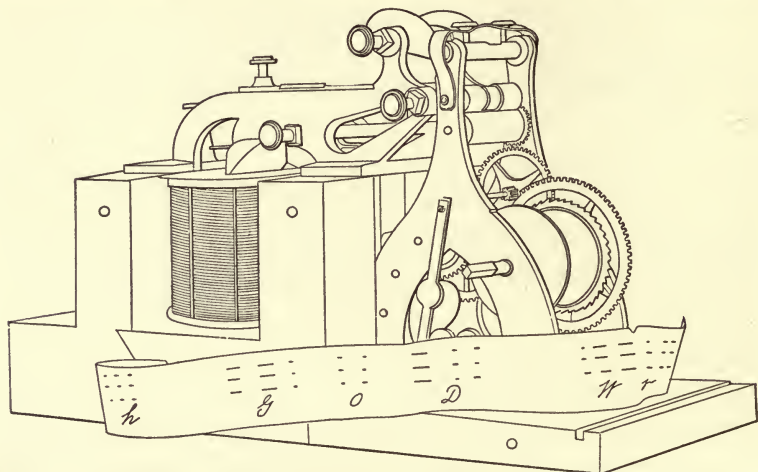

FIG. 170. One of the original Morse Registers used on the Washington-Baltimore line.*

As the matter of receiving instruments is of the greatest importance, it is treated more fully on page 359 of this chapter.

In simplex as well as in other lines the range of direct operation is limited. Direct working can be carried on over a line about 400 miles in length in damp climates, and over nearly a thousand miles in dry climates. Longer lines must be composed of a series of separate electric circuits interconnected by means of repeaters. Each division is supplied with current from independent sources. The repeater is composed of two modified relays, not unlike the one shown in Fig. 10, except that the armature is supplied with both front and back contacts. The repeater must consist of two relays

* This instrument is preserved in the Museum of Sibley College, Cornell University.

suitably interconnected, as it is necessary to work the line in both directions. If the transmitting section of the line be connected to the solenoid terminals of the relay, and the

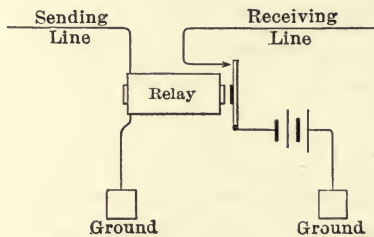

FIG. 171. Simple Repeater Circuit operating in one direction only.

contact terminals are connected with the receiving division of the line with fresh battery in circuit, as shown in Fig. 171, messages can be sent in one direction only. It is therefore necessary to have a second repeater connected in the reverse direction. Fig. 172 shows complete repeater connections for a simplex line. Such an arrangement of

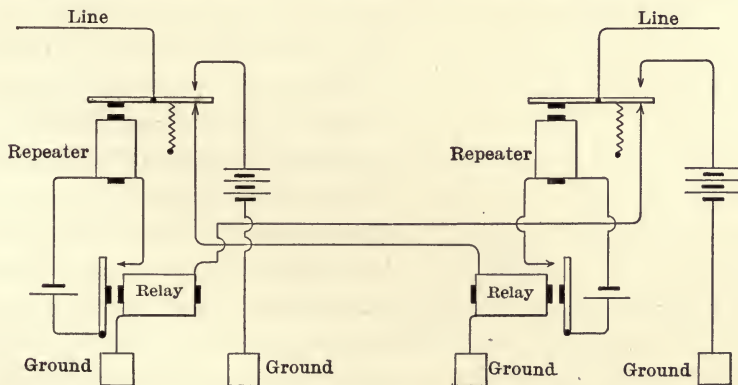

FIG. 172. Diagram of Repeater Circuits showing the principles involved but omitting detail.

instruments is known as an *automatic repeater* because it works without any attention. Messages are sometimes repeated by hand, especially where one central office is re-

quired to repeat from a long transmission line to a number of local lines. The New York Central Office of the Commercial Cable Company has in operation from 500 to 1000 automatic repeaters, the function of which is to furnish fresh current for messages *en route* between the west and east, e.g., between Chicago and Boston.

Duplex System. It is possible, by means of an invention known as the differentially-wound relay, to transmit messages in both directions over a line at the same time. The connections for this arrangement are shown by diagram in Fig. 173. For simplicity the local sounder circuits are omitted

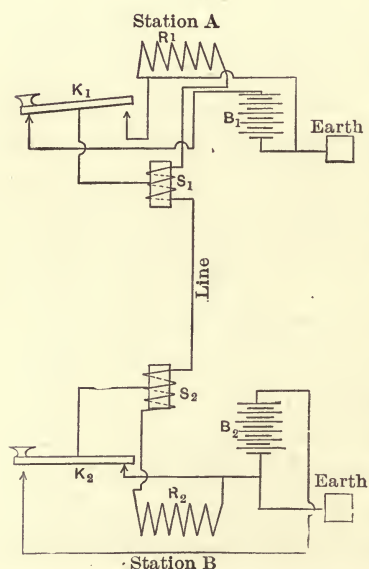

FIG. 173. Differential Duplex Telegraph Circuits.

from this diagram, and S_1 and S_2 represent the differentially wound relays. Current is supplied to these relays at the central points, so that if the current divides equally between the two halves of the winding the relay cores are not magnetized. The general principle underlying this *differential duplex system* can be best understood by tracing out the connections with the various possible combinations. From the hinges of the keys current passes through the relay solenoids by either or both of two paths. One is through the artificial resistance R_1 or R_2 (either of which is

equal to the resistance of the line) to the earth. If the current divides equally through the relay solenoid, the relay armature

will not be attracted. If for any reason it does not divide equally the relay will operate. Suppose that the operator at Station A, wishing to send a message to Station B depresses his key K_1 . Current flows through battery B_1 , through key K_1 , through relay S_1 , dividing between artificial resistance R_1 , and the line. The current which flows through the line energizes relay S_2 because it flows through but one half of its windings. The current then passes to earth through the back contact of key K_2 . The sending operator hears nothing from his own instrument, but he operates the instrument in Station B. The sending operator at Station A is able, therefore, to signal to the receiving operator at Station B.* Suppose farther that the sending operator in Station B desires to transmit a message to the receiving operator in Station A, while the first message is going in the other direction. He depresses key K_2 , and if at the particular instant key K_1 is not depressed the signal is transmitted through the line as before, but in the other direction. If both keys happen to be depressed at the same time, the batteries oppose each other in the line, and no current therefore can flow through it. Current does, however, flow through the grounded sections of both relays as follows: From the batteries through the keys, through the relays, through the artificial resistance back to the batteries. The receiving instruments therefore are operated by the local batteries, but the signals are transmitted as if two separate lines were used. This duplexing of the line results in a doubling of its efficiency, and at the present time any line is duplexed when there is sufficient business to warrant the employment of the extra operators.

Lines may be duplexed by another method known as the Wheatstone or *bridge duplex system*. This is illustrated in

* There must obviously be two operators at each station; one to receive, and the other to transmit messages.

diagram, Fig. 174. The well-known Wheatstone bridge, which is familiarly used for measuring unknown resistances, is well adapted to telegraphic purposes. The method is not

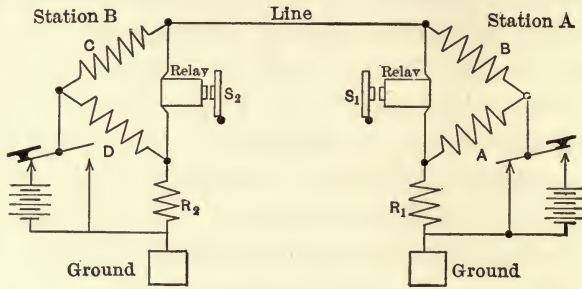

FIG. 174. Bridge Duplex Telegraph Circuits.

essentially different from the differential duplex. Referring to the diagram, suppose that the operator at Station B depresses his key. The current will flow by two paths, one to earth through bridge-arm *D*, and artificial resistance R_2 , the other through bridge-arm *C*, and line, and at Station A it will divide between bridge-arm *B* and the circuit containing the relay S_1 . The relay at Station B will not be operated because there is no difference of potential between its terminals, the bridge-arms being so adjusted that this will be the case.

When both keys are depressed at the same time the batteries oppose each other in the line, as in the differential duplex, each relay then being operated by its own current.

Quadruplex Telegraphy. The efficiency of a line may be increased fourfold by transmitting two messages each way at the same time. This is possible by employing two distinct types of relay. One is the standard Morse relay, already described, adjusted to operate with the current above a certain minimum value. When current below this value is sent

over the line the relay fails to respond. The second relay is of the "polarized" variety. Its armature is a permanent magnet, one pole being at the hinge, the other being free to play backward and forward between the poles of an electromagnet. When current is sent through the coils of the relay in one direction, the armature is attracted to one pole, and when the current is reversed the armature is attracted to the other pole. The polarized relay therefore responds to changes in the direction of the current. The armature of the standard Morse relay, which has a soft iron core, is attracted by a current in either direction. With these two types of relay it is possible to send two messages over the same wire at the same time, by means of two transmitting keys, one of which reverses the current, while the other changes the strength of the current. The line is duplexed by the bridge or differential system previously described.

It should be understood that the above descriptions of telegraph systems do not contain the details met with in practice. In order to insure rapid working, non-interference from other circuits, protection from lighting disturbances, and reliability, the use of numerous details is necessary. The function of these can only be learned by practical experience. The systems described are typical, and serve to point out the general principles involved.

Receiving Devices. As already stated the original receiver used by Morse indented dots and dashes on a moving strip of paper. This instrument is known as the Morse *register*. It was found unnecessary in most cases to use the recording part of the register, as operators became skillful in interpreting the sounds made by it. The sounder was, therefore, developed. Mention has also been made of the still older pith-ball, used in the electroscope receivers, which were supplanted by the

needle telegraph soon after Professor Oersted's discovery. The needle telegraph and the Morse register and sounder are still in common use, the former being well adapted to feeble currents, the latter to the strong currents in local circuits.

A very delicate form of recording instrument was developed by Sir William Thomson (late Lord Kelvin) for use in connection with transmission over cables in which but a small current can be used. The name *siphon recorder* is given to this instrument. A coil of fine wire is suspended between the poles of a powerful electro-magnet, as in the D'Arsonval galvanometer. The line current passes through this coil, which is supported by a fiber suspension. The movements of the coil are transmitted by a thread to a capillary glass tube siphon, the upper end of which dips into an ink reservoir. The other end of the tube plays over a moving paper tape. When current is sent through the movable coil in one direction or the other, the latter is correspondently deflected and transmits its motion to the siphon, which produces a wavy line upon the tape. A current in one direction corresponds to the dash, and one in the other to the dot of the telegraph alphabet. In order to cause ink to flow through the capillary tube, it is electrified by connection to a small auxiliary static machine.

A modification of the Thomson siphon recorder is in use in many large telegraph offices in this country. It is known as the Cuttriss magnetic siphon recorder. The improvement consists in a device for rendering more certain the flow of ink. Attached to the lower end of the siphon is a small piece of soft iron, and under the paper tape is located an electro-magnet. The magnetic flux in this magnet is varied by means of a vibrator which opens and closes the solenoid circuit. This is an arrangement somewhat like the mechanism of an electric bell comprising a solenoid, connected in series with a battery, and an adjustable "make-and-break." The

armature of the vibrator has attached to it a glass tube partly filled with mercury, and connected by a rubber tube with a mercury reservoir. By means of an adjusting screw in this reservoir the amount of mercury in the vibrating glass tube can be varied, and its rate of vibration controlled.

Printing Telegraph Systems. There is a certain demand for a telegraph record, which will be legible to any one not familiar with the Morse code. In reporting the stock quotations to brokers' offices this is especially important. The general principle of these "tickers" is as follows:

The transmitting apparatus sends a number of impulses corresponding to the number of letters of the alphabet; for *a*, one impulse; *b*, two; *c*, three, etc. The receiving apparatus comprises a rotating type wheel with a step-by-step mechanism for turning it through a definite angle corresponding to a particular letter. This mechanism is either a pawl-and-ratchet, or an escapement similar to that of a watch or clock. The pawl-and-ratchet furnishes its own motive power, while the escapement requires a weight or spring. The paper tape is automatically pressed against the type wheel by an electromagnet when the wheel has been rotated to the proper position.

Automatic Systems. A number of high speed automatic systems have been devised for the purpose of increasing line efficiency by transmitting messages over simplex or duplex lines at a rate many times as great as is possible by manual transmission. A number of such methods have been brought to perfection, and several are gradually coming into use. The details are complicated, and the general principle need only be outlined. The simplest systems employ a paper tape, which is perforated with holes on both sides of the center line. A hole on one side corresponds to a dash, while one on the other side corresponds to a dot. This tape may be perforated

by hand with the aid of a simple double key punch, or an automatic punch may be used. In the transmitter the tape is fed beneath a pair of metal contact fingers, so that the circuit is completed whenever a hole passes under one or other of the fingers, sending current to the line in the corresponding direction. This reversing current may be made to operate any kind of a recorder which is sufficiently delicate to respond to its variations.

For very high speed work it is necessary to receive the messages either upon a photographic plate or film, or upon a strip of chemically prepared paper. The latter by electrolysis, will be colored when the current passes through it. There is then no limit to the speed of the apparatus, except as set by the mechanical and the chemical properties of the instruments.

Wireless Telegraphy. The discharge from an induction coil sets up electric waves, which radiate throughout space. These waves have the property of affecting the contact resistance of metal particles or of an electrolytic cell. The operation of wireless telegraphy consists, therefore, in sending out through space impulses of electro-magnetic waves, and receiving these upon sensitive arrangements involving the above property.

Fig. 175 shows in diagram a simple wireless telegraph circuit.

It consists of two parts, the transmitting apparatus and the receiving apparatus. In the primary circuit of the induction coil are a battery and a key. In this circuit there is the interrupter *I*, bridged across which is a condenser. When the key is depressed the current flows intermittently through the primary of the induction coil, and produces intermittent high frequency e. m. f. in its secondary. Across the secondary is the spark gap, which is adjusted to discharge when-

ever the key is depressed. One side of the spark gap is connected with an aerial wire, which is suspended in the air from considerable height. In very large stations this "aerial" takes the form of a great wire network. The other terminal

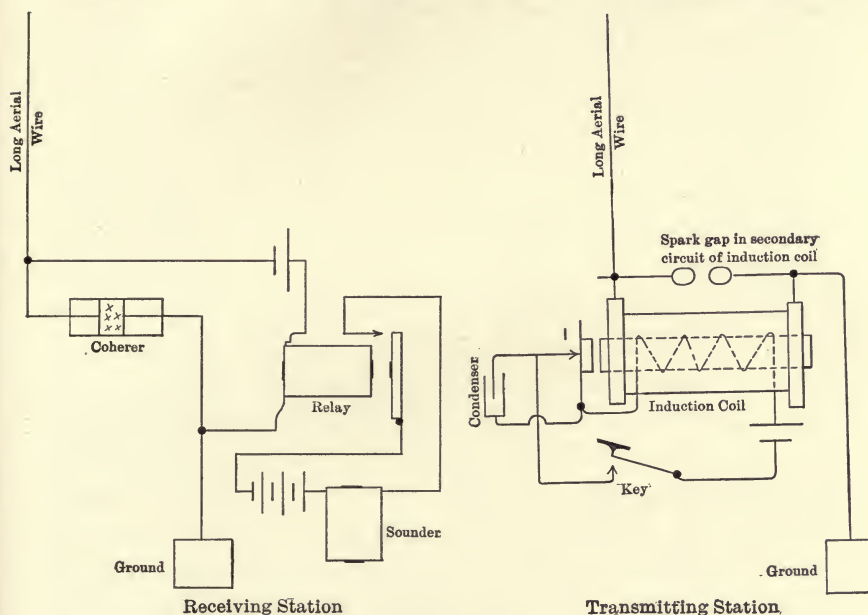

FIG. 175. Elements of a simple Wireless Telegraph Circuit.

of the spark gap is grounded. Whenever the key is depressed, electro-magnetic waves emanate from the aerial throughout space.

The waves are received on a second aerial which is grounded through the "coherer." The latter consists of a glass tube partly filled with fine nickel filings. In traversing these filings the waves greatly reduce the contact resistance between them. In parallel with the coherer is a battery and relay circuit. Whenever the resistance of the coherer is reduced, current flows through the circuit and operates the relay. When the waves cease the coherer filings retain their low resistance

positions, and it is necessary to have a vibrating tapper to shake them loose. The secondary circuit of the relay is connected through a battery and sounder, or other receiving apparatus already described. With equipment of this kind modified in detail to suit various conditions messages may be transmitted hundreds of miles. With more delicate apparatus operated on the same principle the range of transmission may be extended to several thousand miles.

The Telautograph. A device invented by Prof. Elisha Gray makes it possible to transmit handwriting over a distance of several miles. The apparatus consists of two parts, one for sending, the other for receiving. The sending operator writes with a stylus upon a strip of paper. Attached to the stylus are two arms having directions approximately at right angles. These arms rotate contact switches, and vary the resistance in two electric circuits. Each position of the stylus corresponds to a definite resistance in each circuit. The currents which flow through the lines are inversely proportional to the resistances. These currents are received in solenoids, which produce upon their cores forces which are proportional to the currents. By means of a lever mechanism these cores operate a pencil, which exactly follows the motion of the sending stylus. The instrument contains numerous ingenious details for moving the paper, and for insuring reliability of operation.

The field of application of this instrument is rather limited. As a number of receiving instruments may be operated by one station, it is possible to secure autograph copies of orders, or of other important information, and this is in many cases very desirable. For example in a large establishment where it is desired to notify at the same time and in writing several departments of the details of an order, it is possible to do this by

means of the telautograph. The government has a large number of the instruments in operation.

Telephony.

The general principle underlying the transmission of speech is that a variation of current in a circuit may be produced by a variation in the resistance. This, in telephony, is caused by the action of the sound waves upon a diaphragm, which controls the resistance. The essential parts of the telephone circuit are:

- (a) The transmitter, which contains the variable resistance.
- (b) The receiver, which reproduces the sound waves by means of a diaphragm, attracted by an electro-magnet, which in turn is excited by the variable current.

In practice, several auxiliaries are found necessary to render the above device practicable. These are:

- (a) An induction coil, which is a small transformer for raising the pressure for transmission. This is necessary because the current in the transmitter circuit is too large, and the drop in e. m. f. across the variable resistance is too small for efficient transmission.
- (b) A switch for connecting the transmitter circuit when communication is desired.
- (c) A ringer for attracting the attention of the party desired.

In connection with the circuit are other auxiliaries which will be mentioned in describing the actual operation of a telephone circuit.

The Transmitter. The diagram of a modern transmitter is shown in Fig. 176. The essential parts are a diaphragm of soft iron placed opposite a mouthpiece, which directs the sound waves against it. Behind the diaphragm is mounted

the variable resistance cell, which consists of a short tube partly filled with loose granular carbon. This carbon is between two carbon-faced terminal plates, one being fixed, the other attached to the diaphragm. The latter vibrates

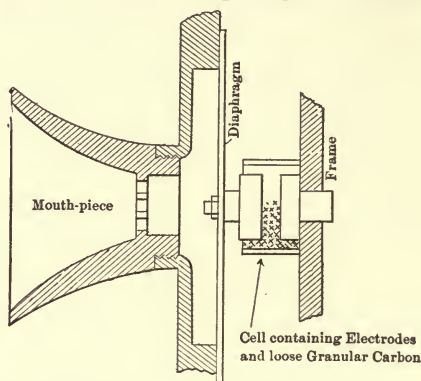

FIG. 176. Essential parts of Granular Carbon Telephone Transmitter.

with the diaphragm and produces a variable pressure upon the granular carbon, thus altering its resistance. The movable terminal is surrounded by a flexible diaphragm to prevent the escape of the loose carbon particles. The transmitter parts are mounted in a substantial metal case, which is supported by an adjustable clamp hinge.

The receiver comprises a soft iron disk placed near the poles of a U-shaped permanent magnet, around which are wound

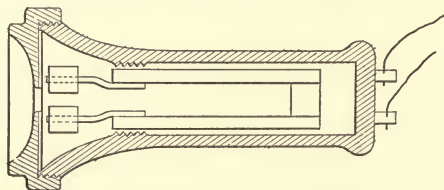

FIG. 177. Essential parts of a Bi-polar Telephone Receiver.

coils of fine wire. Variations in the current surrounding the magnet produce corresponding motion of the diaphragm, and

thus reproduce the sound waves. A permanent magnet is used rather than a soft iron core, because it produces a greater change in magnetic flux for a given change in current with the very small m. m. f. which is available. The essentials of the receiver are shown in Fig. 177.

The Ringer. Alternating current is used for the ringing circuits of the telephone. Originally this was supplied by a small magneto-generator operated by the calling subscribers. At present the ringing current is furnished by the central office. The ringer itself operates on the principle of the polarized relay already described. This is illustrated in Fig. 178. The armature of the ringer is not permanently polarized

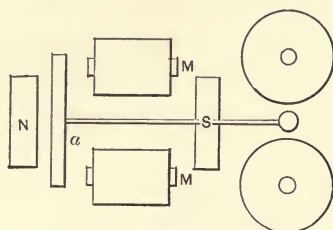

FIG. 178. Diagram of the Magnetic Circuits of an Alternating Current Bell.

but is under the influence of a permanent magnet, marked *NS*. When current is sent through the solenoids *MM*, in one direction, the poles induced by the permanent magnet in the armature *a* are weakened on one side, and strengthened on the other. This action is reversed when the current is reversed in the solenoid, so that with alternating current the armature clapper vibrates.

The subscriber's station in a modern telephone system is illustrated in Fig. II, page 13. When the telephone is not in use the receiver *R* hangs upon a hook switch *H*. The line circuit then is complete through the ringer *m* and the condenser *c*. As alternating current passes through the con-

denser, which will not conduct direct current, the alternating ringing current meets no great obstruction. When the receiver is lifted from the hook, the ringer circuit is disconnected, and the receiver and transmitter circuit is connected to the line. In some forms of subscriber's station, the direct current for talking is supplied by a local battery. This arrangement is, however, being rapidly superseded by one in which both ringing and talking current come from the central office. Such a system is naturally known as a *common battery* or *central energy system*.

A simple set of connections for a common battery system is given in Fig. 179.* The connections for two subscribers

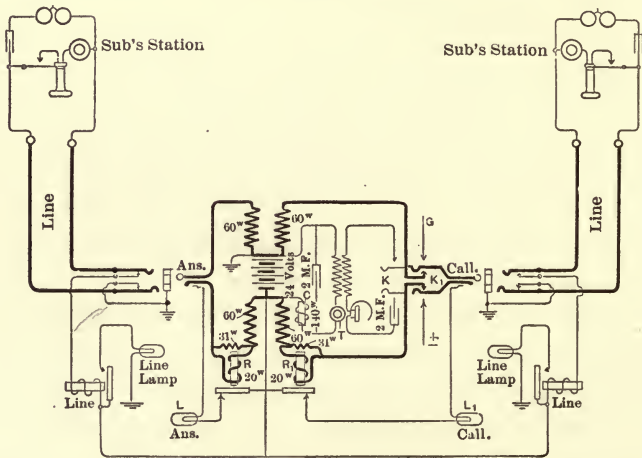

FIG. 179. Diagram of a pair of Circuits in a Common Battery Telephone Exchange.

are shown in this diagram. The central part of the diagram represents the apparatus in the central office. The subscribers' lines are brought into the office through protectors and lightning arresters. The wires are connected with small springs known as

* FIG. 179 is reproduced by permission from K. B. Miller's Modern Telephone Practice.

“jacks,” connections with which are made by three-wire cords, terminating in “plugs.” When the plugs are inserted in the jacks they make connections between the springs and the wires of the cord circuit. The plugs are indicated in diagram by *ans.*, and *call.*, which are the answering and calling plugs respectively.

In order to understand the diagram it will be simplest to follow through the operation of connecting up two subscribers. Suppose that the subscriber on the left-hand side desires to talk with the one on the right-hand side of the illustration. The calling subscriber lifts his receiver from the hook, thereby short-circuiting his line through his transmitter. At the office a small lamp is lighted by the operation of the line relay, indicating the call to the operator. The operator then inserts the answering plug, which disconnects the line lamp. The operator closes the listening key K , by turning a cam (which presses the two springs apart) and inquires as to the number wanted. The operator then inserts the calling plug into the jack of the subscriber desired, and operates the ringing key K_1 , by pressing the springs apart as before, thus making contact with the alternating current ringing circuit. As soon as the calling plug is inserted the “supervisory” calling lamp L_1 is lighted. When the second subscriber removes his receiver from the hook, this calling lamp is extinguished by the operation of the relay R_1 , which is in the main line circuit. The two subscribers can now talk, their transmitters being supplied with current from the large battery located at the central office. When either subscriber returns his receiver to the hook, he breaks his circuit, and the relay R or R_1 opens, closing the corresponding lamp circuit and indicating to the operator that the conversation is over. These lamps indicate at all times to the operator the condition of the circuits, and hence are usually called *supervisory* lamps.

Telephone Exchanges and Central Offices. Mr. K. B. Miller defines a telephone office as "an establishment in which telephone lines center, containing equipment for interconnecting the lines." According to the same authority "a telephone exchange is an organization of one or more telephone offices, and the connecting lines and sub-station equipments necessary for supplying telephone service to a community."

The telephone office contains the switchboards for interconnecting the subscribers; the power plant for supplying current for all purposes; and the protective and distributing apparatus for increasing efficiency and reliability.

The switchboard comprises the apparatus shown in diagram in Fig. 179, including the calling and answering jacks, the supervisory lamps, the cord circuits, the relays, etc. The switchboard is divided into panels or sections, placing within the reach of one operator from fifty to several hundred answering jacks, and several thousand calling jacks in a large office. The number assigned to each operator depends upon the amount of business. Under ordinary circumstances one hundred calling circuits can be easily handled. In offices of moderate size each operator can reach the answering jacks of all the subscribers, these jacks being connected in multiple in the various sections of the switchboard. This arrangement gives the name *multiple board* to such an equipment. It is the ordinary arrangement at the present time.

In very large exchanges there are usually several central offices, which are connected by "trunk" lines, so that a subscriber in the district of one office may be connected to one in the district of another office. The circuits of the subscribers in the district of a given office terminate in a multiple board as already described, which is ordinarily called the "A" board, and the subscribers' operators are for convenience denominated "A" operators. A separate board or separate

section of the same board is devoted to the trunk lines. This is the "B" board, and the operators are the "B" operators. The "B" operators make no connections directly with the subscribers' lines, but they connect the "A" board circuits with the trunk lines when subscribers in other office districts are wanted.

It should be stated that the multiple board is not in exclusive use in this country. A radically different plan is the "transfer" system. In this, each operator handles circuits of a limited number of subscribers only. When connection between two subscribers in different sections of the switchboard are desired, the operator of the calling subscriber notifies a second operator in charge of an auxiliary switchboard, by inserting a plug in the calling jack. The operator of this second board ascertains from the subscriber what number is wanted, and in turn notifies a third operator in charge of the section in which the second subscriber is located. The last-named operator makes the connection and calls the desired subscriber. In this way the call has been *transferred* from the first operator to the second, then to the third. The auxiliary board is connected to the others by trunk lines, and its function is to interconnect subscriber circuits in various parts of the office.

The purpose of the transfer plan is to simplify the switchboard construction, which becomes very complicated when large numbers of subscribers are to be served by a multiple board.

The power plant in a telephone exchange consists usually of one or more motor-generator sets, the motor being selected to suit the available source of power supply. This may be single or polyphase alternating current, or direct current of any e. m. f. The generator is of about 30 volts e. m. f. and of

a few horse power capacity. A storage battery is ordinarily used to supplement the generator. In addition a ringer is necessary for the purpose of supplying alternating current to the circuits for calling purposes. The power plants are also supplied with complete switchboards for operating the motors and generators.

Telephone Distributing Circuits. The construction of telephone circuits for connecting the subscribers with the central office is not essentially different from that already described for power circuits. For underground distribution and in many cases for overhead circuits, lead covered cables are employed. The conductors are pairs of copper wires insulated with dry paper, loosely wrapped, the conductors being laid in spiral layers alternately right and left hand. The purpose of the loose wrapping is to keep the conductors separated a sufficient distance, to minimize the electrostatic capacity.

For pole lines, hard drawn copper is usually used, weighing from 200 to 300 pounds per mile. Iron wire is in use to a limited extent, but only where cheapness is the prime consideration. The poles are placed from 40 to 50 to the mile, and they range from 30 to 65 feet in height. The wires are supported upon glass insulators giving about 100 megohm insulation resistance per mile in wet weather. The joints in the hard drawn copper wire are made with the McIntire connector. This consists of two copper tubes, joined side by side, into which the ends of the wire to be joined are inserted. The joint is then spirally twisted several times. This joint is used instead of solder in order to avoid danger of destroying the strength of the wire by heat.

Conduits are used between large cities to an increasing extent to avoid the troubles incident to the use of overhead circuits. Even where such interurban conduits are not

employed, conduit is used from the suburbs to the centers of the large cities, as it is impossible to handle many lines in city streets.

Wireless Telephony. The success of wireless telegraphy has inspired inventors to devise wireless telephony schemes. Some of these attempts now appear to be reasonably successful, and transmission has been carried on over several miles. The same form of waves is used as in wireless telegraphy, and the intensity of these waves is varied by means of a microphone circuit. The source of the high frequency currents is a "whistling" arc connected in the primary circuit of a transformer. Such an arc operated from a d. c. circuit produces electro-magnetic waves of the same nature as those emanating from a spark gap. The transmitter is connected in the arc circuit. The metal coherer described is not sensitive enough for telephony. The more delicate electrolytic receptor is necessary.

APPENDIX.

Fields of Application of Alternating and Continuous Current.

Although many classes of work can be performed equally well by either alternating or continuous current, each is peculiarly adapted to certain uses. This division of the fields of application, while not rigid, can be seen by a study of the following table.

Alternating Current.

1. Power transmission over large or small areas.
2. Incandescent lighting over large areas.
Current transmitted at high pressure and transformed to low pressure by means of constant potential static transformers.
3. Arc lighting.
In many locations there is not enough arc lighting business to warrant the use of continuous current arc generators. In others the a. c. lamp is preferred for its economy and convenience. For these cases alternating current arc lamps, operated in series on a constant potential circuit and with current regulating devices in series, are very satisfactory. The lamps may also be operated in parallel, in which case a lamp adjusted for operation on constant potential would be employed.
4. Constant speed motors and in a few cases variable speed motors.

5. Electrical furnaces.

Such as are used for the manufacture of carborundum, graphite, etc.

Continuous Current.

1. Incandescent lighting.

Over small areas, especially in the crowded districts of large cities, in which the pressure necessary for the lamps can be used economically in the transmission.

2. Arc lighting.

The uni-directional current is well adapted to arc lighting, pulsating current being generally used. On account of the superiority of the alternating current from the transmission standpoint, the continuous current arc lamp is being gradually driven from the field.

3. Variable speed motors.

Practically all of this line of work, which includes electric traction, cranes, etc., is best served by the constant potential series, continuous current motor.

4. Constant speed motors.

Such are used in factories for the driving of tools and of line shafts and for general power purposes in the crowded districts of large cities. While called *constant speed* these motors may be varied in speed by means of various devices, but when the speed has been set thus, it is maintained regardless of the load. In the previous class of motors mentioned, the speed varies with the load.

5. Electrolysis.

The continuous current finds an excellent field in the reduction of metals and the production of

many chemical compounds very cheaply. In the storage battery a very useful adjunct to lighting and power stations is found.

Historically the application of the continuous current to these various uses was first, but in importance it may be said that now the alternating current is first. The latter is more easily produced as the generator is simpler. It owes its superiority, however, to the fact that it may be transformed in pressure in stationary apparatus, with practically no loss. This important point makes possible the transmission of electric power over long distances and it has forced the manufacturing companies to develop lines of apparatus, in all directions possible, which can be used on alternating current circuits.

Classification on the Basis of Pressures Employed.

Alternating Current.

1. 1,000 to 3,000 volts, constant potential, usually single phase.

Applicable to arc and incandescent lighting. For the former a constant current is maintained by a constant current transformer or a constant current regulator. Or, either arc or incandescent lamps may be operated in parallel on from 100 to 250 volts, constant potential, reduced from the line pressure by constant potential transformers.

2. 2,000 to 7,000 (or more) volts, constant potential, usually three-phase.

This is used for power transmission purposes under ten miles, particularly for power distribution for railways in large cities. For this purpose the alternating current is transformed to continuous current in rotary converters located in sub-stations from which the power can be economically transmitted at 500 volts pressure.

3. 6,000 to 80,000 volts, constant potential, generated two-phase or three-phase, but transmitted on a three-phase line.

Transformation from two-phase to three-phase is easily accomplished in static transformers. These high pressures are used for power transmission purposes up to several hundred miles, the power being generated at a moderate pressure of about 10,000 volts which is raised to the pressure desired for the line by means of constant potential transformers.

4. Miscellaneous pressures used for electro-chemical and electro-metallurgical purposes.

This current is usually generated at a fairly high pressure and is then stepped down to any pressure desired. It is converted to continuous current for electrolysis. The pressure depends upon the process used and the number of tanks connected in series.

Continuous Current.

1. 6 to 350 volts, constant potential for electrolysis.

This includes the reduction of metals and the formation of various chemical compounds.

2. 50 to 550 volts, constant potential used for incandescent lamps and constant potential arc lamps.

The standard pressures are from 104 to 250 volts for the two-wire and from 208 to 500 for the three-wire system.

3. 110 to 550 volts, constant potential used for motors of both constant and variable speed.

In addition to this classification upon a pressure basis there should be mentioned the constant current system, both

alternating and continuous current. This is popular for arc lighting especially for out-of-door purposes. From three to ten amperes are used for this purpose. Occasionally constant current motors are used on the continuous current circuit, but they are not satisfactory and their use is to be disparaged except where no other source of current is available.

REVIEW QUESTIONS.

INTRODUCTION.

1. Give a synopsis of the applications of the electric current.
2. Describe its application to the transmission of mechanical power.
3. How is light produced by the electric current?
4. What is incandescence? Luminescence?
5. How is light produced in the arc lamp? How in the vapor lamp?
6. What is electrolysis? Give three examples.
7. Why is the electric current the only means for the long distance transmission of intelligence?
8. How is this accomplished with the electric current?
9. Describe a simple telegraph system, with diagram of same.
10. Upon what principle does the telegraph operate?
11. Describe the operation of the telephone.
12. Give a simple diagram of the telephone circuit.
13. What essential parts constitute the electric heater?
14. How is carborundum produced?
15. What can be said of the generation of energy in electric generators?

CHAPTER I.

HISTORICAL DEVELOPMENT.

1. Of what three periods does the development of electrical engineering consist?
2. Explain the status of the science at the close of the period of mystery.
3. With whom did the period of scientific preparation begin?
4. What was the result of his work?
5. By whom was the first electric machine invented? Of what did it consist?
6. Who improved upon this machine and in what manner?
7. Who discovered that electricity could be transmitted?
8. By whom were materials separated into conductors and non-conductors?
9. What was the first example of the storage of electricity?
10. To what modern type of apparatus did this lead?
11. For what electrical discoveries is Benjamin Franklin noted?

12. What discovery led to the invention of the Voltaic cell?
13. How did this invention facilitate the further development of electrical apparatus?
14. For what is Sir Humphrey Davy noted? To what did his discoveries lead?
15. By whom and in what manner was the connection between electricity and magnetism discovered?
16. What was the Arago disk? To what discoveries did it lead?
17. Describe the experiments and discoveries of Faraday.
18. By whom was the first electric motor invented?

COMMERCIAL DEVELOPMENT.

19. At what time does this period begin?
20. How much was known of the theory of electrical machinery at this time?
21. Discuss the growth of the transmission of intelligence.
22. Describe the development of electric lighting.
23. What early experiments lead to the development of electro-chemistry?
24. Discuss the development of the storage battery.
25. What other applications of electricity have been made to chemical engineering?
26. Trace the development of the electric generator.
27. Trace the development of the transformer. To what did it lead?
28. Discuss the development of power transmission.
29. Describe the development of the electric motor.
30. Discuss the development of electric traction.
31. What recent developments have been made in electric traction?

CHAPTER II.

FUNDAMENTAL QUANTITIES.

1. When electric current flows through the Arago disk, from center to rim, what occurs? What does this show?
2. If the current is reversed what occurs? What does this show?
3. If a weaker magnet is substituted, what will be the result? To what conclusion does this lead?
4. What is Ohm's law? How may it be illustrated?
5. How does the speed of rotation of the disk affect the e.m.f. produced? How is this effect shown?
6. To what is the product of current and e.m.f. in a circuit proportional? How may this be demonstrated?
7. How may the identity of mechanical and electrical power be shown?
8. How does the electrical power taken from a generator compare with the mechanical power supplied to it?
9. What is Joule's law? How may it be illustrated?

ELECTRICAL UNITS.

10. What are legal standards? How do they differ from absolute units?
11. Define the legal unit of current; of resistance; of electromotive force.
12. What is the unit of power? How is it defined?
13. What is the unit of electrical energy?
14. Name and define the practical unit of electrical quantity.
15. What is inductance? Name and define its unit.

16. What is capacity? Name and define its unit.
17. What is the unit of strength of magnetic field? Define it.
18. Define the following units in the absolute or C.G.S. system: (a) Strength of magnetic field, (b) Unit of e.m.f., (c) Unit of current, (d) Unit of quantity, (e) Unit of power, (f) Unit of energy, (g) Unit of resistance, (h) Unit of inductance, (i) Unit of capacity.
19. What are the three properties of the electric circuit?
20. Give the corresponding mechanical analogies.

CHAPTER III.

MATERIALS.

1. For what purposes are materials used in electrical machines?
2. Classify the materials into four groups.
3. Define conducting materials.
4. Why is copper the most important conducting material?
5. Describe the process by which copper is prepared.
6. Describe the process by which aluminum is prepared.
7. Compare copper and aluminum as to (a) Conductivity, (b) Tensile strength, (c) Weight, (d) Cost, (e) Ease of manipulation.
8. Discuss iron and steel as conductors.
9. How do alloys differ from the pure metals in their electrical properties? Name the alloys in common use for carrying current.
10. Discuss carbon as a conductor.
11. Under what conditions are liquids used as conductors?

PROPERTIES OF MATERIALS.

12. What is specific resistance?
13. Define the circular mil, the mil-foot.
14. Define temperature coefficient. About what is it for copper?
15. Summarize the properties of (a) Copper, (b) Aluminum, (c) Iron and Steel, (d) Alloys, (e) Carbon.
16. What is a wire gauge? Discuss the B. & S. gauge.

MAGNETIC MATERIALS.

17. Name the magnetic materials.
18. Define magnetic material.
19. What is magnetic induction?
20. Discuss Ewing's theory of magnetism.
21. Define permeability.
22. Define magnetic flux.
23. Define the maxwell, the gilbert, magnetomotive force.
24. Discuss the production of e.m.f. by a conductor cutting a magnetic field.
25. Discuss the mechanical reaction between a magnetic field and a conductor carrying current.
26. What is hysteresis? Define hysteresis coefficient.
27. What factors influence the permeability of a magnetic material? Discuss the effect of each of these factors.
28. Give an expression for the power loss in iron, due to hysteresis.
29. What is retentiveness? To what is it due? In what cases is it undesirable? In what cases is it desirable?

30. Discuss the magnetic properties of (a) Cast steel, (b) Cast iron, (c) Electrical steel.

31. What is a $B-H$ curve? What does it show?

INSULATING MATERIALS.

32. Of what use are insulating materials?

33. Name the principal insulating materials.

34. What properties should these materials possess?

35. What is dielectric strength? Electric pressure rupturing gradient? Specific inductive capacity?

36. What can be said of the specific resistance of dielectrics?

37. Discuss the insulating properties of air, glass and porcelain, mica, rubber, paper and fiber, waxes and varnish, oils, cloth and yarn.

CHAPTER IV.

ELECTRIC CIRCUITS.

1. Of what distinct sections does an electric circuit consist?

2. According to what rules is all indoor wiring installed?

3. In what way are these rules compiled? How enforced? By whom adopted?

4. Describe the overhead transmission system; the underground system.

5. In what classes may indoor wiring be grouped? Discuss these classes as to (a) expense, (b) durability, (c) appearance.

6. Of what parts may an electric circuit consist?

7. Name the varieties of current. Distinguish between these kinds.

8. What three properties may an electric circuit have? Which of these are of more influence in alternating current circuits than in continuous current circuits?

ALTERNATING QUANTITIES.

9. Define Alternation, Cycle, Period, Frequency.

10. What law does the ordinary alternating e.m.f. or current approximately follow?

11. What is the effective value of an alternating quantity? How is it determined? What is its value for a sine wave? So also for the average value.

12. What is the "power factor" of a circuit?

13. What is the expression for average power in an alternating current circuit?

14. What is meant by two alternating quantities being "out of phase"?

15. What effect does the phase relation of current and voltage in an alternating current circuit have on the power in the circuit? Express power factor as a function of this relation.

16. What is a polyphase circuit? A two-phase circuit? A three-phase circuit?

RESISTANCE, INDUCTANCE AND CAPACITY.

17. What effects have inductance and capacity in alternating current circuits?

18. How may the effect of inductance be expressed in an equation? So also for capacity.

19. Describe briefly the method of determining the effect in a circuit of a certain irregular current flowing in turn through inductance, resistance and capacity.

20. If a circuit has a resistance of 50 ohms and an inductive reactance of 100 ohms, what drop in voltage occurs when a current of 10 amperes flows through the circuit?

CHAPTER V.

MAGNETIC CIRCUITS.

1. What is a magnetic circuit?
2. Give illustrations of the practical application of the magnetic circuit.
3. Give three functions of magnetic flux.
4. Give the equation for pull exerted by a magnet in terms of area of contact and flux density.
5. What is a $B-H$ curve? In what units may it be expressed?
6. What is reluctance? What is its formula?
7. What is magnetic leakage? How does it represent loss? How may it be kept low?
8. Knowing flux density in a magnetic circuit, length of path and turns in the exciting winding, how may the necessary current be found?

THE TRANSFORMER.

9. What is a transformer? What is its purpose? What part does magnetic flux play in its performance?

EXCITATION OF GENERATORS AND MOTORS.

10. Give five ways in which the field excitation of generators may be produced.
11. Describe each of the ways of the above question.
12. Knowing the exciting ampere-turns to be used in a shunt generator, the voltage of the machine, watts loss in excitation and mean length of field turn, how is the number of turns, resistance of winding and size of wire determined? How may the results be checked?
13. In what cases is the series winding used?
14. Answer question 12 for the series generator.
15. Why are generators often provided with a compounding winding?
16. How is the proper number of series turns to give a certain degree of compounding determined?
17. Give simple diagrams for the shunt wound, the series, and the compound wound generator.

CHAPTER VI.

CONSTRUCTION OF GENERATORS.

1. What are the essential elements of all electric generators?
2. What apparatus was the forerunner of the modern generator?
3. Along what lines did the generator first develop?
4. What three essential features are found in all generators?

THE ALTERNATOR.

5. Describe the armature of the alternator.
6. Describe the field magnet of the alternator.
7. Describe the current collecting devices.
8. From what source is the field current for alternators taken?
9. Describe the coils of these machines.
10. Discuss alternator windings.
11. Discuss two-phase and three-phase windings.
12. How is adequate ventilation of alternators secured?

THE DIRECT CURRENT GENERATOR.

13. What radical differences exist between the alternator and the direct current machine?
14. Explain with the aid of diagrams the operation of commutation.
15. Describe the armature of direct current machines.
16. Discuss the series winding.
17. Discuss the lap or parallel winding.
18. How many brushes are used in the two cases?
19. Describe the commutator.
20. Describe the field magnet of the d.c. generator.
21. How do the series winding and the shunt winding of the field usually differ in appearance?
22. How are the field coils connected with each other and with the armature?

CHAPTER VII.

OPERATION OF ELECTRIC GENERATORS.

1. What is the general purpose of electric generators?
2. What is meant by the regulation of any machine? Of a waterwheel? Of a constant potential generator? Of a constant current generator?
3. What are the conditions for determining regulation of generators, as specified by the rules of the A.I.E.E.?

ALTERNATOR CHARACTERISTICS.

4. What are characteristic curves and what do they show?
5. How does the allowable voltage regulation for incandescent lamps compare with that for motors? Why?
6. What effect has the power factor of the circuit upon the regulation of alternators?
7. Explain the importance of the efficiency of generators.
8. What is meant by the iron-loss in an alternator? Upon what does it depend?
9. What is the saturation curve of an alternator? Of what importance is it?
10. What causes heating in the alternator? What temperature rise is allowable in the windings of machines?
11. What is the short circuit characteristic of an alternator? How is it obtained? What does it show? What practical use is made of it?
12. What is meant by the "synchronizing" of alternators?
13. How is synchronizing accomplished? What conditions must be met? What purpose is served?
14. Give the diagram of connections for synchronizing two alternators.
15. How may the load be properly distributed between alternators operating in parallel?
16. How are the phases of alternators balanced as to load?

D.C. GENERATOR CHARACTERISTICS.

17. Why cannot a shunt generator maintain a constant terminal voltage with changing load?
18. Explain in detail the operations which take place during commutation.
19. What is meant by a "reversing field"?

20. Draw and explain the shape of the compounding curve of a d.c. generator.
21. Draw and explain the saturation curve of a generator.
22. How is the e.m.f. of generators governed?
23. Why cannot compound generators be connected in parallel without an "equalizer"? Explain its action.
24. How is the load distributed between d.c. generators operating in parallel?

CHAPTER VIII.

TRANSFORMERS.

1. What apparatus first contained the elements of the transformer?
2. What phenomena did it illustrate?
3. What imperfections existed in this first apparatus?
4. Explain the principles upon which the transformer operates.
5. How does magnetic leakage affect its action?
6. What are "primary coils"; "secondary coils"; "step-down transformer"; "step-up transformer"?
7. Give the general definition of the transformer. Name four varieties.
8. Describe the construction of the constant potential transformer.
9. Distinguish between "shell-type" and "core-type" transformers.
10. For a 1000-volt transformer having two primary and two secondary coils with a ratio of 10 to 1, give the possible ratios of transformation.
11. Discuss the modern transformer as to (a) Magnetic leakage, (b) Insulation, (c) Ventilation, (d) The core and copper losses.
12. How are transformers protected from lightning?
13. What is an auto-transformer?
14. Discuss the series or current transformer as to (a) Construction, (b) Application.
15. Discuss the constant current transformer as to (a) Construction, (b) Operation, (c) Application.
16. What is the constant current regulator? How does it operate? For what is it used?

TRANSFORMER CHARACTERISTICS.

17. Define regulation for a constant potential transformer.
18. About what per cent regulation may be expected from good transformers of this type?
19. What losses occur in transformers? Upon what do these losses depend?
20. Define efficiency. How is it determined for the transformer?
21. About what is the efficiency of a modern constant potential transformer?
22. Discuss the heating of transformers.
23. What determines the value of the exciting current when the transformer is connected to a given line?
24. What determines the voltage to which it is safe to connect the transformer?
25. What is the magnetizing component of the exciting current?
26. What loss of power does it represent?
27. What is the core-loss component of the exciting current?
28. Distinguish between "energy efficiency" and "power efficiency." What is the "all day efficiency"?

29. Discuss the characteristics of the constant current transformer.
30. Discuss the installation of transformers.
31. How are transformers used in polyphase systems?
32. How may transformers be used to change from two-phase to three-phase currents?
33. How may six phases be produced from a three-phase system, by the use of transformers?

CHAPTER IX.

POWER PLANTS.

1. What is meant by the term "power plant"?
2. Discuss the source of power for a power plant.
3. What governs the choice of electric generators to be used?
4. What power auxiliaries are usually installed?
5. What is a switchboard? What is its purpose in the power plant?
6. Discuss lightning phenomena in electric circuits.
7. How are electric circuits protected from the effects of lightning?
8. Describe the typical lightning arrester.
9. What are ground detectors and how are they used?
10. Describe the knife switch; the oil switch; the circuit breaker.

PLANT CONSTRUCTION.

11. In the Winona station how is the coal handled and stored?
12. Describe the steam piping in this station.
13. In such a station about what steam consumption may be expected?
14. What provision is made for supplying direct current for local railway use?
15. What is the direct current for exciting the fields of alternators here generated?
16. What chief differences mark the vertical steam turbine plant from the reciprocating engine plant?
17. Describe the coal handling system of the Detroit plant.
18. What economies are attempted in handling the feed water in the Detroit plant?
19. Describe the chief features of the Long Island plant.
20. Describe a typical hydro-electric plant.
21. What can be said of the efficiency of gas engine plants?
22. Describe the gas producer of the plant.
23. Trace the path of the air from the inlet to the gas tank.
24. Describe the electrical equipment of the gas engine plant.

STORAGE BATTERIES.

25. Why are storage batteries installed in power stations?
26. Describe the typical battery cell.
27. What is meant by "straightening the load curve"?
28. How do storage batteries keep up the voltage of the plant at heavy loads?
29. How does the battery improve engine and generator performance?
30. Why is the storage battery often installed in substations?
31. Describe the chloride accumulator. Why so named?
32. What chemical changes take place during charge and discharge?
33. What determines the amount of energy which can be stored in a battery?

34. How is the capacity of storage batteries rated?
35. What is a battery booster? What is its purpose?
36. What is a booster regulator? Describe the carbon-pile regulator.
37. Under what conditions of operation is the battery most efficient?
38. What can be said of the depreciation of storage batteries?
39. What is meant by the terms "buckling" and "sulphating"?

POWER STATION OPERATION.

40. Discuss power station characteristics.
41. What is the load curve? What is the typical shape of this curve?
42. What effect may the storage battery have upon the load curve?

CHAPTER X.

1. How is torque produced in an electric motor?
2. To what is this torque proportional?
3. What controls the direction of rotation of d.c. motors?
4. What causes have led to the development of the different types of motors?
5. Name the different types of motors and the corresponding types of generators.

SYNCHRONOUS A.C. MOTORS.

6. Explain the principle of the synchronous motor.
7. Give a mechanical analogy illustrating this.
8. Describe the construction of this motor.
9. How is the synchronous motor started?
10. How is the speed controlled?

INDUCTION MOTORS.

11. Explain the principle of the induction motor.
12. Explain the production of the rotating field.
13. What is "slip" and to what is it due?
14. Describe the construction of the induction motor.
15. How is the induction motor started?
16. How may the speed of this motor be controlled?

SERIES A.C. MOTORS.

17. How does the series a.c. motor operate?
18. Of what parts does it consist?
19. For what service is this motor adapted? Why?
20. Describe the repulsion motor.

D.C. MOTORS.

21. Describe the shunt wound motor.
22. How does the compound motor differ from the shunt?
23. In what ways may the series field of the compound motor be connected? What different effects are secured in this way?

SERIES D.C. MOTORS.

24. What influences have governed the development of the series motor?
25. To what peculiarities of construction have these led?
26. To what classes of service is the series motor adapted? Why?

THE INTERPOLE MOTOR.

27. What is the interpole motor?
28. What is the object of the interpoles? How is this accomplished?
29. How does the use of the interpole motor make possible the transmission of d.c. power for greater distances than before?

MOTOR CHARACTERISTICS.

30. What are the important characteristics of the following motors: (a) Synchronous, (b) Induction, (c) Series a.c., (d) Series d.c., (e) Shunt d.c., (f) Compound d.c.?
31. What are the V -curves of the synchronous motor?
32. What do they illustrate as to (a) Power factor, (b) Best field current for the motor, (c) Armature current for constant output but varying field current?
33. Explain the shape of the following curves for the induction motor: (a) Amperes input, (b) Speed and slip, (c) Power factor.
34. How does the speed of shunt wound motors vary with increase of load? How does the efficiency vary?
35. How does the speed of series motors vary with the current input? How does the tractive effort vary?

MOTOR STARTING.

36. How are motors generally started?
37. What, in general, governs the speed of motors?
38. How does the starting of synchronous motors differ from that of other types?
39. Give three methods for starting rotary converters.
40. How are single-phase induction motors started? How is the speed controlled?
41. Describe the typical motor starter with underload and overload release.

CHAPTER XI.

INCANDESCENT LAMPS.

1. Upon what principle does the incandescent lamp operate?
2. Describe the manufacture of the carbon filament of the lamp
3. In what manner is the filament of the tungsten lamp made?
4. What is the average consumption in "watts per candle" of carbon filament lamps?
5. In what way does the regulation of e.m.f. at the lamp terminals affect its life and efficiency?
6. From the curves on p. 308 determine the effect upon the life and candle power of increasing the e.m.f. at the lamp by 2 per cent; of decreasing it 2 per cent.
7. Explain the term "smashing point."
8. Describe the Nernst lamp. Why is a ballast resistance necessary?

ARC LAMPS.

9. Upon what principle does the arc lamp operate?
10. Why is carbon used in arc lamps?
11. In what ways do d.c. and a.c. arcs differ?
12. What new forms of arc lamp have recently been developed?
13. What materials are used to replace carbon, in the magnetite lamp?
14. Distinguish between *series* and *multiple* lamps.

15. Describe the construction and operation of the differential lamp, the shunt lamp, the multiple lamp.

16. How does "ballast resistance" steady the current in an arc lamp.

17. Compare open and enclosed arcs as to: (a) Efficiency, (b) Distribution of light, (c) Life of carbons.

18. Discuss the rating of arc lamps.

VAPOR LAMPS.

19. Describe the vacuum tube lamp.

20. Describe the mercury vapor lamp.

FIELDS OF APPLICATION OF ELECTRIC LAMPS.

21. Discuss the application of incandescent lamps.

22. Discuss the application of arc lamps.

23. Discuss the application of vapor lamps.

LIGHT AND ILLUMINATION.

24. How do the following light sources compare as to cost per 1000 candle-hours: The carbon filament lamp, the common arc lamp, the Welsbach gas lamp, the kerosene lamp?

25. What distinction should be made between "light" and "illumination"?

26. What can be said as to the efficiency of light production by the electric lamps in common use?

UNITS OF LIGHT AND ILLUMINATION.

27. Define the "hefner," the "foot-candle."

28. How does the intensity of light radiated from a point vary with distance?

29. What is the intensity of light on a screen 4 feet in a horizontal direction from a standard candle, and making an angle of 45 degrees with the horizontal?

ELECTRIC HEATING.

30. How is electrical energy transformed into heat?

31. How efficiently is this process accomplished?

32. How does the cost of heating a certain amount of water by electric heater and gas flame compare?

33. What are the main applications of electric heating?

CHAPTER XII.

MEASURING INSTRUMENTS.

1. For what electrical measurements are instruments required?

2. What quantities are measured by them?

3. What classes of instruments are used in the measurement of current?

ELECTRO-DYNAMOMETER.

4. Describe the electro-dynamometer.

5. Why is the electro-dynamometer equally adapted to the measurement of direct and alternating current?

6. How do the deflections of the electro-dynamometer vary with the current flowing? Explain.

7. What types of this instrument have been developed?

8. What is an ammeter shunt? Explain its use.

PERMANENT MAGNET AMMETERS.

9. How is the deflecting force produced in these meters?
10. Describe the movable magnet ammeter.
11. What can be said of this meter as to sensitiveness, simplicity, portability?
12. Describe the moving coil permanent magnet ammeter.
13. What can be said of the regularity of scale of this meter?
14. How are these meters made "dead beat"?

SOFT IRON CORE METERS.

15. Upon what principle do these meters operate?
16. What types of this meter have been developed?
17. Discuss the coil-and-plunger type meter.
18. Discuss the Thomson inclined-coil meter.

INSTRUMENTS FOR MEASURING QUANTITY.

19. What is electrical quantity?
20. Upon what principles are methods of measuring quantity based?

INSTRUMENTS FOR MEASURING E.M.F.

21. What principles are employed in these instruments?
22. Describe the electrostatic voltmeter.
23. Discuss the various types of high-resistance-ammeter voltmeters.

HOT WIRE INSTRUMENTS.

24. Explain the principle and mechanism of the hot wire meter.

WATTMETERS.

25. To what must the deflection of wattmeters be proportional?
26. How is this accomplished?
27. Of what practical importance is the energy meter?
28. Describe a typical energy meter.
29. For what kinds of current is the commutator-type meter adapted? Why?
30. Discuss the induction-motor meter.
31. Why is this meter limited to a.c. circuits?
32. What special instruments are needed in the fully equipped power house?
33. Discuss briefly the power factor and frequency meters.

CHAPTER XIII.

1. How may intelligence be transmitted by the aid of the electric current?

TELEGRAPHY.

2. Discuss simplex telegraphy as to (a) Method of transmitting messages, (b) Connection of keys and relays in closed circuit systems, (c) Current supply, (d) Receiving instruments, (e) Range of operation, (f) Simple diagram of circuits.
3. Discuss duplex telegraphy as to (a) Differential-wound relay, (b) Diagram of circuits, (c) Operation of apparatus, (d) Efficiency of the system, (e) Bridge system of duplexing.
4. According to what principles may a line be "quadruplexed"?
5. Discuss telegraphic receiving devices; the needle telegraph; the syphon recorder.
6. Explain the principle of the printing telegraph systems, or the "ticker."
7. What automatic systems have been introduced?

WIRELESS TELEGRAPHY.

8. Explain the principle of wireless telegraphy.
9. Give a diagram of the simple wireless system.
10. Explain the action of (a) The aerial, (b) The induction coil, (c) The spark gap, (d) The coherer, (e) The "tapper."

THE TELAUTOGRAPH.

11. What is the telautograph?
12. Explain its operation.

TELEPHONY.

13. What general principle underlies the method of transmission of speech?
14. What are the essential parts of the telephone circuit?
15. Discuss the telephone transmitter.
16. Discuss the telephone receiver.
17. What is the "ringer"?
18. What is a "central-energy system"?
19. Describe the telephone "jack."
20. Describe the operation of connecting the apparatus of two subscribers in the central-energy system.
21. What is a telephone exchange?
22. What is meant by a "multiple board" equipment?
23. What is the "transfer system"?
24. Discuss telephone system power plants.
25. Discuss the distributing circuits of a telephone system.
26. Discuss the status of wireless telephony.

INDEX.

- "A" board, telephone, 370.
A. C. circuits, 113.
A. C. motors, synchronous, 265.
A. C. power, 119.
A. C. series motor, 49.
A. C. series motor characteristics, 283.
A. C. series motors, 272.
A. C. transmission for railways, 49.
Accumulator handling, 251.
Adam's electric car, 48.
Addition of sine waves, 128.
Advances in telegraphy, 30.
Aerial, wireless telegraph, 363.
Age of electricity, Benjamin's, 18.
Ageing, magnetic, 90.
Air as a dielectric, 97.
Air-blast transformers, 199.
A. I. E. E. definitions of regulation, 179.
A. I. E. E. standardization code, extracts from, 179-185.
Air main in gas plant, 245.
Air tower in gas plant, 245.
All-day efficiency of transformers, 210.
Alloys as resistance materials, 74.
Alloys, fusible, 79.
Alloys, steel, 95.
Alphabet, Morse telegraph, 352.
Alternating current, 113.
Alternating current and e.m.f., 117.
Alternating current, fields of application of, 374.
Alternating current, heating value of the, 118.
Alternating quantities, effective values of, 118.
Alternating quantities in the steam engine, 114.
Alternator, 152.
Alternator armature, 152.
Alternator brushes, 160, 161.
Alternator, characteristic curves of, 183.
Alternator characteristics, 181.
Alternator, compensated, 151.
Alternation, definition of, 117.
Alternator, de Meritens', 40.
Alternator, Deri's, 40.
Alternator efficiency, 184.
Alternator efficiency, data on, 182.
Alternator e. m. f. wave, 117.
Alternator excitation, 138.
Alternator excitation, 165.
Alternator, Ferranti's, 40.
Alternator field coils, 164, 165.
Alternator field cores, 161.
Alternator field magnets, 160.
Alternator field, number of poles in, 161.
Alternator, Ganz's, 40.
Alternator, Gramme's, 40.
Alternator handling, 187.
Alternator heating, 184.
Alternator iron loss, 184.
Alternator, Kapp's, 40.
Alternator, Mordey's, 40.
Alternator regulation, 181.
Alternator regulation, data on, 182.
Alternator, revolving armature, 152.
Alternator, revolving field, 152.
Alternator, revolving field, view of, 162.
Alternator, Schuckert's, 40.
Alternator, von Hefner Alteneck's, 40.
Alternator, Westinghouse's, 40.
Alternator, Westinghouse, view of, 152.
Alternator, Zipernowski's, 40.

- Alternators, distribution of load among, 188.
 Alternators, early, 39.
 Alternators in parallel, 188.
 Alternators, synchronizing, 187.
 Alumina, 76.
 Aluminum compared with copper, 76, 77.
 Aluminum for power lines, 106.
 Aluminum manufacture, 75, 76.
 Aluminum, properties of, 76.
 Aluminum, specific resistance of, 81.
 Aluminum, summary of properties of, 82.
 Aluminum, temperature coefficient of, 81.
 Aluminum reduction, 78.
 Amber, early knowledge of, 18.
 American gage, 83.
 Ammeter and shunt, 309.
 Ammeter, inclined coil, 342.
 Ammeter shunts, 335.
 Ammeter, Weston, 338.
 Ammeters, coil and plunger, 341.
 Ammeters, electro-dynamometer, 331.
 Ammeters, hot wire, 347.
 Ammeters, movable coil, permanent magnet, 338.
 Ammeters, permanent magnet, 331, 336.
 Ammeters, soft core, 331, 340.
 Ammeters, straight line law in, 340.
 Ammeters with rotating soft-iron cores, 341.
 Ampere, C. G. S. definition of, 68.
 Ampere, definition of, 59.
 Ampere, Electric locomotive named the, 47.
 Ampere's mathematical work, 24.
 Ampere-turn, m. m. f. of, 85.
 Angström's coefficient, 324.
 Annealing, effect upon permeability, 89.
 Annealing steel sheets, 94.
 Anthony and Moler, 39.
 Application of electric lamps, 320.
 Applications of electric current, synopsis of, 1.
 Applications of motors, 298.
 Arago, Dominique-Francois, 24.
 Arago, papers of, 37.
 Arago's disk experiment, 24.
 Arc, forms of, 315.
 Arc lamp applications, 322.
 Arc lamp, Blondel, 315.
 Arc lamp, Bremer, 315.
 Arc lamp carbons, 80.
 Arc lamp construction, 316.
 Arc lamp, development of, 34.
 Arc lamp, flaming, 8.
 Arc lamp, magnetite, 35, 316.
 Arc lamp, mercury, 8.
 Arc lamps, 6, 313.
 Arc lamps, Brush's work on, 35.
 Arc lamps, constant current, 316.
 Arc lamps, constant current transformers for, 203.
 Arc lamps, constant potential, 316.
 Arc lamps, development of, 34.
 Arc lamps, differential, 316.
 Arc lamps, early, 33.
 Arc lamps, enclosed, 35.
 Arc lamps, Farmer's work on, 35.
 Arc lamps, flaming, 35, 315.
 Arc lamps, light produced by, 319.
 Arc lamps, multiple, 316.
 Arc lamps, shunt, 317.
 Arc lamps, series, 316.
 Arc light, first, 24.
 Arc lighting in Paris, early, 34.
 Arc, luminosity of, 313.
 Arc, volts required to maintain an, 313.
 Arcs, distribution of light from, 315.
 Arcs, open and enclosed, 318.
 Armature, alternator, 152.
 Armature, Gramme's ring, 39.
 Armature coils, 155.
 Armature coils for railway motors, 279.
 Armature core, 152.
 Armature cores, d. c. generator, 169.
 Armature cores, eddy currents in, 153.
 Armature of generator, 151.
 Armature of railway motor, 279.
 Armature of the electric generator, 150.
 Armature, Paccinotti's, 38.

- Armature, ring, 38.
 Armature, Siemens', 38.
 Armature slot forms, 154.
 Armature ventilation, 160-162.
 Armature, view of stationary, 153.
 Armature, views of large d. c., 168.
 Armature winding, 2-phase, 157.
 Armature winding, lap or parallel, 172.
 Armature winding, series d. c., 169.
 Armature winding, 3-phase, 156.
 Armature winding, wave, d. c., 169.
 Armature windings, 156.
 Armatures of d. c. generators, 168.
 Automatic repeaters, 355.
 Automatic telegraph systems, 361.
 Automatic telegraphy, 30.
 Auto-transformer in motor starting, 289.
 Auto-transformers, 202.
 Auxiliaries in power stations, 218.
- "B" board, telephone, 371.
 Balance, Kelvin or Thomson, 333.
 Balancing phases in polyphase circuits, 188.
 Barlow, Peter, 26.
 Barlow's electric motor, 26.
 Barlow's wheel, modified form of, 52.
 Bases for incandescent lamps, 304.
 Battery boosters and regulators, 250.
 Battery storage, 11.
 Battery, the storage, 36.
 Bauxite, 76.
 Bell, Alexander Graham, 31.
 Bell's telephone, 31.
 Benjamin, Age of Electricity, 18.
 Benjamin Franklin, electric locomotive named the, 47.
 Benjamin, Intellectual Rise in Electricity, 18.
 Bentley and Knight, electric car of, 47.
 Bequerel, A. C., 37.
 Bequerel's work in electro-chemistry, 37.
 Berliner, Emile, 32.
 Berlin Exposition, electric car at, 46.
 Berliner's transmitter, 32.
 B. H. curves, referred to, 88.
- Bi-polar telephone receiver, 366.
 Blake, Francis, 32.
 Blondel arc lamps, 315.
 Blondel flaming arc lamps, 35.
 Blower in gas plant, 245.
 Boat, first electric, 43.
 Boosters, battery, 250.
 Bottle, electric, 21.
 Box, water, 80.
 Brake, magnetic, 132, 133.
 Bremer arc lamps, 315.
 Bremer flaming arc lamps, 35.
 Bridge duplex telegraphy, 357.
 Brown and Sharp gage, 83.
 Brown, C. E. L., transmission at Kassel, 41.
 Brush, Charles F., 35.
 Brush holders, 175.
 Brush holders for railway motors, 279.
 Brush, work in electric generators, 39.
 Brush's work on arc lamps, 35.
 Brushes, carbon for, 79.
 Brushes for d. c. generators, 175.
 Brushes in alternators, 160, 161.
 Buckling of battery plates, 252.
 Buffalo Railway Co., load curve, 254.
 Building up of excitation, 140.
 Bulbs for incandescent lamps, 304.
- Candle-foot, 326.
 Candle, Jablochhoff, 34.
 Candle-power, definition of, 326.
 Candle-power of arc lamps, 319.
 Candle power of incandescent lamps, 308, 309.
 Capacity analogous to elasticity, 71.
 Capacity, C. G. S. unit of, 70.
 Capacity of storage batteries, 249.
 Capacity in electric circuits, 125.
 Capacity, mechanical analogy of, 63.
 Capacity reactance, 126, 127.
 Capacity, specific inductive, 96.
 Capacity, unit of, 64.
 Car, Adam's electric, 48
 Car, at Berlin Exposition, electric, 46.
 Car, Bentley and Knight electric, 47.

- Car, Davenport's electric, 45.
 Car, Davidson's electric, 45.
 Car, Farmer's electric, 46.
 Car, Green's electric, 46.
 Car, Grove battery on, 46.
 Car heater, electric, 14.
 Car, Henry's electric, 48.
 Car, Hall's reversible electric, 46.
 Car, Jacobi motor on, 46.
 Car, Page's electric, 46.
 Car, Short's electric, 48.
 Car, Siemens and Halske electric, 46.
 Car, Sprague's electric, 46.
 Car, Van de Poel's electric, 47.
 Carbon arc, 313.
 Carbon as a resistance material, 74.
 Carbon arcs, appearance of various, 314.
 Carbon, effect upon permeability, 89.
 Carbon filaments, 304.
 Carbon in arc lamps, 80.
 Carbon, summary of properties of, 83.
 Carbon transmitter, 366.
 Carbon, 79.
 Carbonizing an incandescent lamp filament, 304.
 Carborundum, manufacture of, 36.
 Carburundum furnace, 14.
 Cast steel, composition of, 93.
 Cast steel, curves of magnetic properties of, 92.
 Cast steel for pole cores, 93.
 Cast steel, magnetic properties of, 93.
 Cast steel field cores, 163.
 Cast steel, permeability of, 89.
 Cast iron, permeability of, 89.
 Cast iron, magnetic properties of, 92.
 Cast iron, curves of magnetic properties of, 91.
 Cast iron, composition of, 92.
 Cavendish, Henry, 22.
 C. G. S. system, units in, 67.
 Cellulose for incandescent lamp filaments, 304.
 Central energy telephone system, 368.
 Central offices, telephone, 370.
 Century of electricity, Mendenhall, 18.
 Characteristic curves of alternator, 183.
 Characteristic curves of generators, 179.
 Characteristics, motor, 281.
 Characteristics of magnetic materials, 92.
 Characteristics, motor speed, 295.
 Characteristics of series d. c. motors, 285.
 Characteristics of series a. c. motors, 283.
 Characteristics of transformers, 206.
 Characteristics of d. c. generators, 189.
 Characteristics of induction motors, 282.
 Characteristics of power stations, 253.
 Characteristics of shunt and compound motors, 285.
 Characteristics, alternator, 181.
 Characteristics of synchronous motors, 281.
 Charging for electrical energy, 262.
 Charging current, 129.
 Chemical composition, effect upon permeability, 88.
 Chemistry, early experiments in electro-, 36.
 Chemical decomposition, electro-, 9.
 Chemical decomposition, first, 24.
 Choke coils for lightning arresters, 221.
 Circuit, function of the electric, 112.
 Circuit, magnetic, definition of, 130.
 Circuits, A. C., 113.
 Circuits, electric, construction of, 102.
 Circuits, varieties of electric, 101.
 Circuits, telephone distributing, 372.
 Circuit-breakers in motor circuits, 302.
 Circuits, transmission, 103.
 Circuits, electric, features of, 101.
 Circuits, properties of electric, 113.
 Circuits, electric, installation of, 102.
 Circuits, polyphase, 121.
 Circuits, design and operation of electric, 111.
 Circuit-breakers, 223.
 Circuits, regulation in electric, 112.
 Circular mil-foot, 80.
 Circular mil, 80.
 Clarke's electric generator, 38.

- Clarke, of London, 38.
 Closed-coil, 2-phase winding, 158.
 Closed winding in d. c. armatures, 169.
 Cloth as a dielectric, 100.
 Code, Morse telegraph, 352.
 Code, National electrical, 102.
 Coefficient, hysteresis, 88.
 Coefficient, temperature, 81.
 Coercive m. m. f., 88.
 Coherer, wireless telegraphy, 363.
 Coil and plunger ammeters, 341.
 Coil pitch in armature windings, 171.
 Coils for armatures, 155.
 Coils for railway motor armatures, 279.
 Coils for transformers, 198.
 Collector rings, 150.
 Collector rings, 159-161.
 Commercial compounding curve, 190.
 Commercial development, period of, 18, 28.
 Commercial development, summary of period of, 50.
 Commercial electric lamps, 303.
 Common battery telephone system, 368.
 Commutation, principles involved in, 167.
 Commutation, review of principles, 189.
 Commutator, 150, 166.
 Commutator, construction of, 174.
 Commutator, view of, 174.
 Commutator motor meters, 348.
 Commutator motor starters, 292.
 Compass, mariner's, 19.
 Compensated alternator, 151.
 Composite winding, 151.
 Compound d. c. motor characteristics, 285.
 Compound excitation, 146.
 Compound excitation, 151.
 Compound motor applications, 300.
 Compound motor speed control, 296.
 Compound motor starting, 293.
 Compound d. c. motors, 273.
 Compound motors, connection of series coil in, 277.
 Compounding, 151.
 Compounding, series turns for, 147.
 Compounding curve, field, 191.
 Compounding curve of d. c. generator, 190.
 Concealed indoor wiring, 108-110.
 Condensers in motor starting, 291.
 Conditions of electric circuits, 70.
 Conducting materials, 73.
 Conducting materials, properties of, 80.
 Conduction of electricity, generation and, 20.
 Conduction, original discovery of, 20.
 Conduction, electric circuit through a, 111.
 Conductors for power lines, 106.
 Conductors to insulators, attaching, 106.
 Conductors and non-conductors, Du Fay's work on, 73.
 Conduit construction, 104.
 Conduit line, 108.
 Conduit, underground, at Cleveland, 47.
 Conduit wiring, indoor, 109, 110.
 Conglomerate ores of copper, 74.
 Connections of transformer windings, 200, 201.
 Constant-current transformer characteristics, 211.
 Constant-current transformer, view of, 204.
 Constant current regulator, 205.
 Constant current transformer, 197, 203.
 Constant potential transformer, 196, 197.
 Construction of electric circuits, 102.
 Construction of electric generators, 184.
 Construction of transmission lines, 104.
 Construction of electric motors, 265.
 Construction and operation of power stations, 217.
 Construction of transformers, 195.
 Consumer's instruments, 330.
 Continuous current, 112.
 Continuous current, fields of application of, 374.
 Control of motors, 287.
 Converter, rotary, 197.

- Converter, rotary, 298.
 Cooking, electric, 36, 328.
 Copper as a conductor, 74.
 Copper compared with aluminum, 76,
 77.
 Copper compared with iron and steel,
 77.
 Copper, electrolytic refining of, 75.
 Copper for commutators, 174.
 Copper, hard drawn, use of, 106.
 Copper losses in transformers, 200.
 Copper for power lines, 106.
 Copper, occurrence in nature, 74.
 Copper refining, 10.
 Copper refining and plating, 37, 38.
 Copper soft drawn, use of, 107.
 Copper, specific resistance of, 81.
 Copper, summary of properties of, 82.
 Copper, temperature coefficient of, 81.
 Copper voltmeter, 343.
 Copper wire manufacture, 75.
 Copper wire table (Inside back cover).
 Core of transformer, 133.
 Core of armature, 152.
 Core loss in d. c. generator, curves of,
 193.
 Core losses in transformers, 200.
 Core loss current in transformers, 210.
 Core type transformer, 197.
 Cores, field, of alternators, 161.
 Cores of d. c. generator armatures, 169.
 Cores of transformers, 198.
 Cornell University power plant, 236.
 Cost of producing electrical energy, 258.
 Coulomb, definition of, 62.
 Coulomb, Chas. A., 22.
 Counter — e. m. f. in motors, 287.
 Crater of arc lamps, 6.
 Cross-arms for pole line, 104.
 Cryolite, 76.
 Current and field, reaction between, 53.
 Current, alternating, 117.
 Current, C. G. S. unit of, 68.
 Current electricity, 23.
 Current, field surrounding a, 63.
 Current measuring instruments, 331.
 Current of series transformers, 202.
 Current regulator, constant, 205.
 Current, unit of, 59.
 Current, varieties of, 112.
 Cuttriss magnetic siphon recorder, 360.
 Cycle, definition of, 117.
 Daft's electric locomotive, 47.
 D'Arsonval galvanometer, 338.
 Dampers on alternator field magnets,
 165.
 Davenport's electric car, 45.
 Davenport's electric motor, 43.
 Davenport, Thomas, 43.
 Davenport, Thomas, 45.
 Davidson's electric car, 45.
 Davidson, Robert, 45.
 Davy's arc lamp, 33.
 Davy's electrical experiments, 24.
 Davy, Sir Humphrey, 24, 33.
 D. C. generator armature, 168.
 D. C. generator characteristics, 189.
 D. C. generator handling, 193.
 D. C. generators in parallel, 194.
 D. C. generator, the, 166.
 D. C. generator, view of, 166.
 D. C. shunt and compound motors, 273.
 D. C. series motors, 277.
 Definition of units, 58.
 Definitions of C. G. S. units, 67.
 Delta-connected, 3-phase winding, 159.
 Delta-connection of transformers, 213.
 de Magneté, Gilbert's, 18, 19.
 de Magneté, illustration from, 20.
 Demagnetizing m. m. f., 88.
 de Meritens alternator, 40.
 Depreciation of storage batteries, 252.
 Deri's alternator, 40.
 Deri's transformer, 40.
 Derived units, 60.
 Design and operation of electric circuits,
 111.
 Detectors, ground, 222.
 Detroit Edison Co., power station, 230.
 Developments in electric traction, recent,
 49.

- Development of the arc lamp, 34.
 Development of the electric generator, 149.
 Development of the incandescent lamp, 33.
 Development, summary of period of commercial, 50.
 Development, period of commercial, 28.
 Dielectric, electric circuit through a, 111.
 Dielectric materials, 73, 95, 97.
 Dielectric resistance, 97.
 Dielectric strength, 96.
 Dielectrics, electrical properties of, 96.
 Difference of phase, 121.
 Differential arc lamps, 316.
 Differential duplex telegraphy, 356.
 Direct current, 112.
 Direct current, fields of application of, 374.
 Disk generator, 52.
 Distribution of mechanical power, 1.
 Dobrowolski's induction motor, 41.
 Drawing of copper wire, 75.
 Drip loop, 103.
 Du Fay's work on conductors and insulators, 73.
 Du Fay, Charles, 21.
 Duplex telegraphy, 30, 356.
 Duplex telegraphy, differential, 356.
 Duplex telegraphy, bridge, 357.
 Duplex telegraphy, Wheatstone, 357.
 Dynamo-electric machine, 148.
 Dynamo, origin of word, 148.
 Dynamometers, electro-, 331.
 Early alternators, 39.
 Early arc lamps, 33.
 Early arc lighting in Paris, 34.
 Early electric motors, 43.
 Early electric traction, 45.
 Early experiments in electro-chemistry, 36.
 Early incandescent lamps, 33.
 Early telegraph systems, 29.
 Economic life of incandescent lamps, 309.
 Economics, power station, 258.
 Eddy currents in armature cores, 153.
 Edison's electric locomotive, 46.
 Edgewise field winding, 164, 165.
 Edison, invention of incandescent lamp, 33.
 Edison, Thomas A., 30.
 Edison, work on electric generators, 39.
 Effective values of alternating quantities, 118.
 Efficiency curve of induction motor, 282, 283.
 Efficiency curve of d. c. motor, 286, 287.
 Efficiency curve of shunt motor, 284, 285.
 Efficiency curves of d. c. generator, 194.
 Efficiency of alternators, data on, 182.
 Efficiency of alternators, 184.
 Efficiency of c. p. transformer, curve of, 209.
 Efficiency of d. c. generator, curve of, 192.
 Efficiency of incandescent lamps, 307.
 Efficiency of light production, 324.
 Efficiency of light sources, table of, 325.
 Efficiency of transformers, 208.
 Efficiency of transformers, all-day, 210.
 Elasticity, electrical analogy of, 63.
 Electric bottle, 21.
 Electric car heater, 14.
 Electric circuit as a fire risk, 103.
 Electric circuits, conditions of, 70.
 Electric circuits, features of, 101.
 Electric circuits, properties of, 70.
 Electric circuits, varieties of, 101.
 Electric current, nature of, 1.
 Electric current, synopsis of applications, 1.
 Electric generator, Clarke's, 38.
 Electric generator, development of the, 149.
 Electric generator, definition of, 148.
 Electric generator, elements of, 148.
 Electric generator, Page's, 38.
 Electric generator, Pixii's, 38.

- Electric generators in power stations, 218.
- Electric generators, operation of, 178.
- Electric heating, 33, 36, 327.
- Electric lamps, commercial, 303.
- Electric lamps, recent improvements in, 35.
- Electric lighting, 33.
- Electric lighting, summary of development of, 50.
- Electric lighting and heating, 303.
- Electric motor, first, 26.
- Electric motors, 263.
- Electric motors, construction of, 265.
- Electric motors, early, 43.
- Electric motor quantity meters, 344.
- Electric motors, recent, 44.
- Electric power, C. G. S., unit of, 69.
- Electric power generation, 38.
- Electric power transmission, 38, 41.
- Electric pressure rupturing gradient, 96.
- Electric waves, Hertzian, 31.
- Electrical auxiliaries in power stations, 219.
- Electrical code, national, 102.
- Electrical energy, charging for, 262.
- Electrical energy, C. G. S., unit of, 69.
- Electrical energy, cost of producing, 258.
- Electrical energy, unit of, 61.
- Electrical generators, construction of, 148.
- Electrical heating in surgery, 329.
- Electrical horsepower, definition of, 61.
- Electrical horsepower hour, definition of, 62.
- Electrical horsepower year, definition of, 62.
- Electrical instruments, applications of, 330.
- Electrical machine, Guericke's, 20.
- Electrical machine, Newton's, 20.
- Electrical and magnetic quantities, fundamental, 51.
- Electrical measurements, 330.
- Electrical motors, principles of, 263.
- Electrical power, 56.
- Electrical power, unit of, 61.
- Electrical properties of dielectrics, 96.
- Electrical properties of materials, 72.
- Electrical quantity, unit of, 62.
- Electrical steel, composition of, 95.
- Electrical steel, curves showing magnetic properties, 94.
- Electrical steel, properties of, 94.
- Electricity, current, 23.
- Electricity, etymology, 18.
- Electricity, generation and conduction of, 20.
- Electricity, storage of, 21.
- Electricity, summary of, development of knowledge of, 50.
- Electro-chemistry, beginning of, 24.
- Electro-chemical decomposition, 9.
- Electro-chemistry, early experiments in, 36.
- Electro-chemistry, summary of development of, 50.
- Electro-dynamometer ammeters, 331.
- Electro-dynamometer, Siemens, 332.
- Electro-dynamometers, 331.
- Electro-dynamometers, portable, 334.
- Electro-dynamometer with gravity control, 333.
- Electro-dynamometer with torsion control, 331.
- Electro-magnetism, 24.
- Electro-magnets, excitation of, 135.
- Electro-magnets, Henry's, 26.
- Electrolyte, electric circuit through an, 111.
- Electrolytic refining of copper, 75.
- Electrolytic quantity meters, 343.
- Electrolysis, 9.
- Electrostatic ground detector, 345.
- Electrostatic voltmeters, 344.
- Elektron, 18.
- Elements of electric generator, 148.
- Elizabeth, Queen, 19.
- Elkington, James B., 37.
- Elkington's work in copper refining, 37.
- E.M.F., alternating, 117.

- E.M.F., calculation of in generator, 86.
 E.M.F., C. G. S., unit of, 68.
 E.M.F., experiment illustrating nature of, 54.
 E.M.F. instruments for measuring, 344.
 E.M.F., unit of, 59.
 Enclosed arc lamps, Mark's, 35.
 Enclosed arcs, 318.
 End turns in transformers, insulation of, 202.
 Energy, charging for electrical, 262.
 Energy, C. G. S. unit of electrical, 69.
 Energy, electrical, unit of, 61.
 Energy, instruments for measuring, 348.
 Energy meters, commutator motor, 348.
 Energy meters, induction motor, 349.
 Energy, transmission of, 15.
 Energy, transformation of, 15.
 Engineering electro-chemistry, 36.
 Equalizer bar or connection, 194.
 Equi-potential connections in lap windings, 173.
 Exact scientific work, early, 22.
 Examples of mechanical power transmission, 2, 4.
 Examples of plant construction, 226.
 Exchanges, telephone, 370.
 Excitation of alternators, 165.
 Excitation, compound, 146, 151.
 Excitation, conditions for self-, 140.
 Excitation of electro-magnets, 135.
 Excitation of generators and motors, 138.
 Excitation, separate, 139, 150.
 Excitation, series, 144, 151.
 Excitation, shunt, 139, 150.
 Excitation of transformers, 137.
 Exciter, 139, 150.
 Exciter, Wilde's magneto, 38.
 Exciters, Long Island Railroad Co.'s station, 234.
 Exciting current in c. p. transformers, 209.
 Exciting current for electro-magnets, 136.
 Ewings' theory, 84.
 Factor, power, 120.
 Farad, C. G. S. definition of, 70.
 Farad, definition of, 65.
 Faraday, experimental researches, 18.
 Faraday and Henry, comparison of work of, 26.
 Faraday, Michael, 25.
 Faraday's discoveries, 25.
 Faraday's disk, modified form of, 52.
 Faraday's magnetic figures, 63.
 Faraday's ring the first transformer, 195.
 Farmer's electric motor, 44.
 Farmer's electric car, 46.
 Farmer, Moses G., 35.
 Farmer's work on arc lamps, 35.
 Faure, Camille, 37.
 Faure's storage battery, 37.
 Ferranti's alternator, 40.
 Ferrari's induction motor, 41, 45.
 Fiber as a dielectric, 99.
 Fields of application of alternating current, 374.
 Fields of application of continuous current, 374.
 Field coil, problem in size of wire for shunt, 143.
 Field coil, problem in size of wire for series, 145.
 Field coils, alternator, 164.
 Field coils for d. c. generators, 176.
 Field core stampings, 163, 164.
 Field cores, cast and sheet steel, 163.
 Field cores, saturation in d. c., 175.
 Field cores of alternators, 161.
 Field cores for d. c. generators, 175.
 Field compounding curve, 191.
 Field's electric locomotive, 46.
 Field magnet of railway motor, 278.
 Field magnet of d. c. generators, 175.
 Field magnet ventilation, 164.
 Field magnets of generators, 151.
 Field magnets of alternators, 160.
 Field, rotating, 267.
 Field strength, magnetic, C. G. S. unit of, 67.
 Field winding, edgewise, 164, 165.

- Filaments for incandescent lamps, 304.
 Filaments, rare metal, 134.
 Fire risk, electric circuit as a, 103.
 Fire risks, transformers as, 213.
 First commercial electro-plating, 37.
 First electric motor, 26.
 First Gramme machine in America, 39.
 First motor in United States, 43.
 First patent on incandescent lamps, 33.
 First successful motor, 43.
 First telephone, 31, 131.
 First telegraph line, 30.
 Flaming arc lamps, 8, 35, 315.
 Flashing an incandescent lamp filament, 304.
 Flux density, effect upon permeability, 88.
 Flux density, magnetic, 85.
 Flux, magnetic, 85.
 Fly-wheel effect, 150.
 Foot-candle, 326.
 Forming an incandescent lamp filament, 304.
 Four-phase circuit, 122.
 Franklin, Benjamin, 22.
 Franklin's experiments, 22.
 Frankfurt, transmission, 42.
 Frequency, definition of, 117.
 Frequency meter, 350.
 Frog-leg experiments, 23.
 Fromant's electric motor, 44.
 Fuller-board as a dielectric, 99.
 Fundamental electrical and magnetic quantities, 51.
 Function of the power station, 253.
 Fundamental units, 59.
 Furnace, carborundum, 14.
 Fuses alloys for, 79.
 Fuses in motor circuits, 302.
 Fusible alloys, 79.

 Gages, wire, 83.
 Galvani, Luigi, 23.
 Galvanometer, D'Arsonval, 338.
 Ganz's alternator, 40.
 Gas collector in gas plant, 246.
 Gas engine plant, typical, 244.
 Gas engine plants, 244.
 Gas generator, 9.
 Gas holder in gas plant, 246.
 Gas producer, 244.
 Gases as dielectrics, 97.
 Gaulard and Gibb's transformer, 40.
 Gauss, C. G. S., definition of, 68, 69.
 Gauss, definition of, 66, 85.
 Generation and conduction of electricity, 20.
 Generator armature, 150, 151.
 Generator characteristics, d. c., 189.
 Generator, Clarke's electric, 38.
 Generator, definition of electric, 148.
 Generator, development of the electric, 149.
 Generator, disk, 52.
 Generator, electric, summary of development of, 50.
 Generator, elements of electric, 148.
 Generator excitation, 138.
 Generator field cores, d. c., 176.
 Generator field magnet, 151.
 Generator field magnet, d. c., 175.
 Generator, flux in air gap of, 86.
 Generator, gas, 9.
 Generator handling, d. c., 193.
 Generator, magnetic circuit in, 150.
 Generator mechanical mounting, 151.
 Generator, Page's electric, 38.
 Generator, Pixii's electric, 38.
 Generator regulation, 178.
 Generator self-excitation, invention of, 38.
 Generator, the d. c., 166.
 Generator, view of d. c., 166.
 Generators, armatures, of d. c., 168.
 Generators as motors, 264.
 Generators and corresponding motors, 264.
 Generators, brushes for d. c., 175.
 Generators, construction of electric, 148.
 Generators, operation of electric, 178.
 German silver, 79.
 German silver, specific resistance of, 81.

- German silver, summary of properties of, 82.
 German silver, temperature coefficient of, 81.
 Gibbs transformer, Gaulard and, 40.
 Gilbert, definition of, 85.
 Gilbert, de Magnete, 18, 19.
 Gilbert, William, 19.
 Glass as a dielectric, 98.
 Glass for line insulators, 105.
 Gradient, electric pressure rupturing, 96.
 Gramme machine, first in America, 39.
 Gramme's alternators, 40.
 Gramme's ring armature, 39.
 Granular carbon telephone transmitter, 366.
 Gray, Elisha, 32.
 Gray iron, curves of magnetic properties of, 93.
 Gray, Stephen, 21.
 Gray's telautograph, 364.
 Gray's telephone transmitter, 132.
 Green, George F., 46.
 Grove battery, on car, 46.
 Ground detector, electrostatic, 345.
 Ground detectors, 222.
 Grounding of circuits, 103.
 Grounding of transformer neutral, 213.
 Grounds on electric circuits, 222.
 Guard wires, 103.
 Guericke, Otto von, 20.
 Guericke's electrical machine, 20.
 Hall, Charles M., 37.
 Hall process, 37, 76.
 Hall, Thomas, 46.
 Hall's reversible car, 46.
 Hall's work on aluminum reduction, 37.
 Halske electric car, Siemens and, 46.
 Hand starting of single-phase motors, 291.
 Handling d. c. generators, 193.
 Handling of alternators, 187.
 Handling motors, 287.
 Handling storage batteries, 251.
 Hardening, effect upon permeability, 89.
 Hard drawn wire, 75.
 Head House, Niagara Falls H. P. & M. Co., 242.
 Heat, production of, 14.
 Heating, electric, 33, 36, 303, 327.
 Heating, electric, application of, 328.
 Heating of alternators, 184.
 Heating of transformers, 209.
 Heating value of the alternating current, 118.
 Heater, electric car, 14.
 Hefner, definition of, 326.
 Henry and Faraday, comparison of work of, 26.
 Henry, C. G. S., definition of, 70.
 Henry, definition of, 64.
 Henry, Joseph, 26.
 Henry's electric car, 48.
 Henry's electro-magnets, 26.
 Henry's electric motor, 44.
 Hertz, Heinrich, 31.
 Hertzian waves, 31.
 High resistance ammeter voltmeters, 346.
 Historical reference works, 18.
 Horn lightning arresters, 107, 220.
 Horizontal steam turbine plants, 233.
 Horsepower, electrical, definition of, 61.
 Hot wire instruments, 347.
 Hughes, D. B., 32.
 Hunning, Henry, 32.
 Hydrogen generator, 9.
 Hydro-electric plants, 236.
 Hysteresis coefficient, 88.
 Hysteresis coefficient, effect of heat upon, 90.
 Hysteresis coefficient, problem illustrating the use of, 91.
 Hysteresis coefficient, relation to permeability, 89.
 Hysteresis in armature cores, 154.
 Hysteresis loss, calculation of, 90.
 Hysteresis, nature of, 88.

- Illumination and light, 323.
 Illumination, amount of, 324.
 Illumination, efficiency of, 324.
 Illumination, intensity, 324.
 Illumination of rooms, chart of, 327.
 Illumination, unit of, 326.
 Impedance, definition of, 126.
 Impedance, problems in, 129.
 Impulse wheel plant, 236.
 Incandescence, 4, 5.
 Incandescent lamp, 5.
 Incandescent lamps, 303.
 Incandescent lamp applications, 320.
 Incandescent lamps, candle power of, 308, 309.
 Incandescent lamps, characteristics, 308.
 Incandescent lamps, development of, 33.
 Incandescent lamps, early, 33.
 Incandescent lamps, efficiency of, 307.
 Incandescent lamps, economic life of, 309.
 Incandescent lamps, Edison's work on, 33.
 Incandescent lamps, filaments for, 304.
 Incandescent lamp, function of, 303.
 Incandescent lamps, life of, 307.
 Incandescent lamp manufacture, 303.
 Incandescent lamp, parts of, 305.
 Incandescent lamps, operation of, 307.
 Incandescent lamps, smashing point, 309.
 Incandescent lamps, Swan's work on, 34.
 Incandescent light, first, 24.
 Inclined coil ammeter, 342.
 Indicator card of steam engine, 114.
 Indicator for power factor, 351.
 Indoor wiring, 108.
 Inductance analogous to inertia, 71.
 Inductance C. G. S., unit of, 69.
 Inductance in electric circuit, 123.
 Inductance, mechanical analogy of, 63.
 Inductance, unit of, 63.
 Induction coil, telephone, 365.
 Induction, definition of, 84.
 Induction motor, 45.
 Induction motors, A. C., 267.
 Induction motor applications, 299.
 Induction motor curves, 282.
 Induction motor characteristics, 282.
 Induction motor, elevation and section of, 269.
 Induction motor, invention of, 41.
 Induction motor meters, 349.
 Induction motor, primary, 270.
 Induction motor, principle of, 267.
 Induction motor secondary, 270, 271.
 Induction motor speed control, 295.
 Induction motor starting, 289.
 Induction motor, summary of history of, 267.
 Induction motor, view of, 268.
 Inductive capacity, specific, 96.
 Inductive reactance, 126, 127.
 Inertia, electrical analogy of, 63.
 Inherent regulation, 178.
 Input curve of induction motor, 282, 283.
 Inspectors, insurance, 102.
 Installation of electrical circuits, 107.
 Insulating materials, 73.
 Insulating lamps, problem in resistance of, 82.
 Insulating materials, 95.
 Insulating materials, list of, 95.
 Insulating material, requirements for, 96.
 Insulation of armature coils, 155.
 Insulation, discovery of, 21.
 Insulation of transformer coils, 95, 200.
 Installation of transformers, 212.
 Insulation of underground conductors, 108.
 Insulation of wires, 95.
 Insulation on line conductors, 107.
 Insulators as targets, 106.
 Insulators, attaching conductors to, 106.
 Insulators, construction of, 105.
 Insulators, Du Fay's experiments with, 21.
 Insulator, link type, 106.
 Insulator pins, 104, 105.

- Instruments, application of electrical, 330.
- Instruments, consumers, 330.
- Instruments, hot wire, 347.
- Instruments in power plants, 330.
- Instruments for measuring current, 331.
- Instruments for measuring e. m. f., 344.
- Instruments for measuring energy, 348.
- Instruments for measuring power, 347.
- Instruments for measuring quantity, 342.
- Instruments, special, 350.
- Intellectual rise in electricity, 18.
- Intelligence, transmission of, 12, 29, 352.
- Intensity of magnetic field, C. G. S. unit of, 67.
- Intensity of magnetic field, unit of, 66.
- Intensity of field, definition of, 67.
- Intensity of illumination, 324.
- Interpole motors, 280.
- Insurance inspectors, 102.
- Iron as a conductor, 77.
- Iron, cast, composition of, 92.
- Iron, cast, curves of magnetic properties of, 91.
- Iron, cast, permeability of, 89.
- Iron, cast, magnetic properties of, 92.
- Iron, cast, strength of, 93.
- Iron compared with copper, 77.
- Iron, gray, curves of magnetic properties of, 93.
- Iron, improvements in magnetic qualities of, 82.
- Iron loss curve of alternator, 183.
- Iron loss in alternators, 184.
- Iron, specific resistance of, 81.
- Iron steel, applications as conductors, 77, 78.
- Iron, summary of properties of, 82.
- Iron, temperature coefficient of, 81.
- Iron, wrought, in magnetic machinery, 95.
- Jablochhoff candle, 34.
- Jacobi motor on car, 46.
- Jacobi, Moritz H., 43.
- Jacobi's motor, 43.
- Jacobi's motor, illustration of, 44.
- Jacks, telephone, 369.
- Joints, 103.
- Joule, C. G. S. definition of, 69.
- Joule, definition of, 61.
- Joule's law, 57.
- Kapp's alternators, 40.
- Kapp, Gisbert, 40.
- Kassel, power transmission at, 41.
- Kelvin balance, 333.
- Key, telegraph, 12.
- Kilowatt, definition of, 61.
- Kilowatt-hour, definition of, 61.
- Knife switch, 224.
- Knight, electric car, Bentley and, 47.
- Knob- and tube wiring, 109.
- Lamp, arc, 6.
- Lamp, development of the incandescent, 33.
- Lamp, enclosed arc, 35.
- Lamp, incandescent, 5.
- Lamp, mercury vapor, 8.
- Lamp, Nernst, 35, 311.
- Lamp, vacuum tube, 78.
- Lamps, arc, 313.
- Lamps, application of electric, 320.
- Lamps, commercial electric, 303.
- Lamps, early arc and incandescent, 33.
- Lamps, flaming arc, 35.
- Lamps, incandescent, 303.
- Lamps, manufacture of incandescent, 303.
- Lamps, mercury vapor, 320.
- Lamps, recent improvements in electric, 35.
- Lamps, vacuum tube, 319.
- Lap or parallel winding for d. c. armatures, 172.
- Lap winding, battery analogy, 173.
- Lap winding, diagram of, 172.
- Lap windings, equipotential connections in, 173.

- Lauffen, power transmission from, 42.
 Laws of the magnetic circuit, 134.
 Leading e. m. f. or current, 120.
 Leakage, magnetic, 136.
 Leyden jar, invention of, 21.
 Lichtenfeld, electric car at, 46.
 Life of incandescent lamps, 307.
 Lifting magnet, 131, 132.
 Light and illumination, 323.
 Light from arc lamps, 319.
 Light, intensity of, 326.
 Light, production of, 4.
 Light production, efficiency of, 324.
 Light, quantity of, 326.
 Light source, function of, 326.
 Light sources, power consumption in, 325.
 Light sources, relative values of, 323.
 Light, units of, 326.
 Lighting, electric, 33, 303.
 Lighting, electric, summary of development of, 50.
 Lighting load curves, 254.
 Lighting, protecting transformers from, 201.
 Lighting of residences, 320.
 Lighting of streets, 321.
 Lightning arresters, 107.
 Lightning arrester connections, 221.
 Lightning arresters in power stations, 220.
 Lightning arrester house, 109.
 Lightning arrester, shunted multi-gap, 222.
 Lightning protection in power stations, 219.
 Lightning, protecting lines from, 107.
 Lightning rod, 19.
 Lightning rod, invention of, 22.
 Limiting temperature rise, 185.
 Line construction, 104.
 Lines, protecting from lightning, 107.
 Link insulator, 106.
 Liquids as resistance materials, 74.
 Liquids as resistances, 80.
 Load curve, Detroit Edison Co., 254.
 Load factor, effect of in power stations, 261.
 Load curve, effect of storage battery on, 255.
 Load curve of Buffalo Railway Co., 254.
 Load curves of railway power station, 256.
 Load curve of railway stations, 254.
 Load curves in power stations, 253.
 Load factor in power stations, 253.
 Locomotive, electric, "Benjamin Franklin," 47.
 Locomotive, Edison's electric, 46.
 Locomotive, the Ampere, drawing of, 47.
 Locomotives, Field's electric, 46.
 Lodestone, early knowledge of, 18.
 Long Island R.R. Co. power station, 233.
 Long Island R.R. Co. substation, 235.
 Long Island R.R. station, exciters in, 234.
 Loop, drip, 103.
 Losses in c. p. transformer, curves of, 208.
 Losses in c. p. transformers, 207.
 Losses in transformers, 200.
 Lowering transformer, 106.
 Lumen, definition of, 321.
 Luminescence, 45.
 Luminous efficiency of light sources, table of, 325.
 Lumination of armature core, 153.
 Lux, definition of, 326.
 Magnesia, Province of, 18.
 Magnet, lifting, 131, 132.
 Magnetic ageing, 90.
 Magnetic and electrical quantities, fundamental, 51.
 Magnetic brake magnet, 132, 133.
 Magnetic circuit, definition of, 130.
 Magnetic circuit, in the generator, 150.
 Magnetic circuit, laws of, 134.
 Magnetic circuits in street railway motor, 130, 131.

- Magnetic field and current, reaction between, 53.
- Magnetic field, illustration of torque produced by, 87.
- Magnetic field intensity, unit of, 66.
- Magnetic field, pulling strength of, 134.
- Magnetic field strength, C. G. S. unit of, 67.
- Magnetic field strength, unit of, 66.
- Magnetic flux, 85.
- Magnetic flux density, 85.
- Magnetic leakage, 136.
- Magnetic leakage in transformers, 199.
- Magnetic material, characteristics of, 92.
- Magnetic materials, 73, 83.
- Magnetic materials, properties of, 88.
- Magnetic permeability, 85.
- Magnetic reluctance, 135.
- Magnetic retentiveness, 91.
- Magnetic units, problem illustrating, 86.
- Magnetism, fundamental facts, 83.
- Magnetism, knowledge of, summary of development of, 50.
- Magnetite arc lamps, 35, 316.
- Magnetizing current in transformers, 210.
- Magneto-electricity, 24.
- Magneto, excitation of, 135.
- Magneto-exciter, Wilde's, 38.
- Magnetomotive force, definition of, 84.
- Magnets, field of alternators, 160.
- Maintenance of power stations, data on, 260.
- Manganin, 79.
- Manganin, specific resistance of, 81.
- Manganin, summary of properties of, 83.
- Manganin, temperature coefficient of, 81.
- Manholes, spacing of, 108.
- Manufacture of aluminum, 75, 76.
- Manufacture of copper wire, 75.
- Manufacture of incandescent lamps, 303.
- Mariner's compass, 19.
- Mark's enclosed arc lamps, 35.
- Marks, L. B., 35.
- Materials, characteristic of magnetic, 92.
- Materials, conducting, 73.
- Materials, dielectric or insulating, 73, 97.
- Materials, electric properties of, 72.
- Materials for ammeter shunts, 335.
- Materials, insulating or dielectric, 95.
- Materials, magnetic, 73, 83.
- Materials of electrical engineering, 72.
- Materials, resistance, 73.
- Materials, properties of conducting, 80.
- Materials, properties of magnetic, 88.
- Maximum demand on power stations, 261.
- Maxwell, definition of, 85.
- McIntire joint, 372.
- Measurements, electrical, 330.
- Mechanical mounting of generators, 151.
- Mechanical power, distribution of, 1.
- Mendenhall, Century of electricity, 18.
- Mercury vapor lamp applications, 322.
- Mercury vapor lamps, 8, 320.
- Mesh-connected, 3-phase winding, 159, 160.
- Mesh-connection of transformers, 213.
- Metallurgy, electric heat in, 329.
- Metallurgy of copper, 74.
- Meter for indicating power factor, 351.
- Meter for measuring frequency, 350.
- Meters, commutator motor, 348.
- Meters, induction motor, 349.
- Mica as a dielectric, 98.
- Mica for commutators, 174.
- Mil, circular, 80.
- Mild steel, curves of magnetic properties, 93.
- Mil-foot, 80.
- Miller, K.B. definition of telephone exchange, 370.
- Milli-volts, 346.
- M.M.F., coercive, 88.

- M.M.F., demagnetizing, 88.
 Molding indoor wiring, 109, 110.
 Moler, Anthony and, 39.
 Mordey's alternator, 40.
 Morse register, 353, 359.
 Morse register, original, 354.
 Morse, S. F. B., 29.
 Morse telegraph alphabet or code, 352.
 Morse's recording telegraph, 29.
 Motor applications, 298.
 Motor characteristics, 281.
 Motor counter — e. m. f., 287.
 Motor, Davenport's, 43.
 Motor, d. c., shunt and compound, 273.
 Motor, electric circuit through a, 111.
 Motor, electric, summary of development of, 50.
 Motor excitation, 138.
 Motor, Farmer's, 44.
 Motor, first electric, 26.
 Motor, Fromant's, 44.
 Motor generators, synchronous, 298.
 Motor handling and control, 287.
 Motor, Henry's, 44.
 Motor, interpole, 280.
 Motor, Jacobi's, 43.
 Motor, Pacconotti's, 44.
 Motor quantity meters, 344.
 Motor, repulsion, 45.
 Motor, series, 44.
 Motor, shunt, 44.
 Motor speed control, 294.
 Motor starting, 287.
 Motor speed characteristics, 295.
 Motor, synchronous, mechanical analogy, 266.
 Motor, synchronous, starting a, 265.
 Motors and corresponding generators, 264.
 Motors, early electric, 43.
 Motors, electric, 263.
 Motors, induction, a. c., 45, 267.
 Motors, protecting against overload, 301.
 Motors, recent electric, 44.
 Motors, series, a. c., 272.
 Motors, series, d. c., 277.
 Motors, synchronous a. c., 45, 265.
 Movable magnet ammeters, 337.
 Multi-gap lightning arresters, 221.
 Multiple arc lamps, 316.
 Multiple switchboard telephone, 370.
 Multiple-unit train control, 49.
 Multipliers for voltmeters, 346.
 Multi-voltage circuits for shop motors, 296.
 Musschenbroeck, Peter von, 21.
 Mystery, summary of period of, 27.
 Mystery, period of, 18.
 National Board of Fire Underwriters, 102.
 National electrical code, 102.
 Nature of electric current, 1.
 Needle telegraph, 29.
 Nernst lamp applications, 322.
 Nernst lamps, 35, 311.
 Neva, electric boat on, 43.
 New York City, electric locomotives in, 47.
 New York, Sprague cars in, 48.
 Newton's electrical machine, 20.
 Newton, Sir Isaac, 20.
 Niagara Falls H. P. & M. Co. power plant, 241.
 Niagara Falls, power stations at, 240.
 Niagara Falls, power transmission from, 3, 4, 43.
 Non-arcing metals, 313.
 Non-conductors, Du Fay's work on conductors and, 73.
 Non-magnetic materials, flux in, 85.
 Oerlikon Machine Works, 41.
 Oersted, Hans Christian, 24.
 Oersted's great discovery, 24.
 Ohm, C. G. S., definition of, 69.
 Ohm, definition of, 59.
 Ohm's law, 55.
 Oil-break switch, 224.

- Oil-insulated transformers, 199.
 Oil in transformers, 100.
 Oils as dielectrics, 100.
 Ontario Power Co., lightning arrester, 107.
 Ontario Power Co., transmission lines of, 34.
 Open arcs, 318.
 Open indoor wiring, 108, 109.
 Operation and construction of power stations, 217.
 Operation of electric generators, 178.
 Operation of incandescent lamps, 307.
 Operation of power stations, 253.
 Operation of power stations, data on, 260.
 Outdoor transmission circuits, 103.
 Over-compounding, 151.
 Over-compounding, 190.
 Overhead lines, 104.
 Overload, protecting motors against, 301.
 Oxygen generator, 9.
- Paccinotti, 38.
 Pacinotti's armature, 38.
 Paccinotti's electric motor, 44.
 Page, C. G., 38.
 Page's electric car, 46.
 Page's electric generator, 38.
 Paper as a dielectric, 99.
 Parallel operation of alternators, 188.
 Parallel or lap winding for d. c. armatures, 172.
 Parallel operation of d. c. generators, 194.
 Paris, early arc lighting in, 34.
 Patent, first on incandescent lamp, 33.
 Peaks in load curves, 253.
 Period, definition of, 117.
 Period of commercial development, 18, 28.
 Period of commercial development, summary of, 50.
 Period of scientific preparation, 18, 19.
 Period of mystery, 18.
- Periods of mystery and scientific preparation, summary of, 27.
 Permanent magnet ammeters, 331.
 Permanent magnets, high carbon steel for, 91.
 Permanent magnet ammeters, 336.
 Permanent magnet ammeters with movable coil, 338.
 Permeability, electrical analogy of, 88.
 Permeability, effect of chemical composition upon, 88.
 Permeability, effect of flux density upon, 88.
 Permeability, effect of physical treatment upon, 88.
 Permeability, magnetic, 85.
 Permeability of non-magnetic materials, 86.
 Permeability, source of, 88.
 Phase difference, 121.
 Phase displacement, 120.
 Phase transformation, 214.
 Phase-splitting devices, 291.
 Phase-wound secondary, 271.
 Phase-winding, use in starting, 290.
 Physical treatment, effect upon permeability, 88.
 Pig-tail brush connectors, 175.
 Pins, insulator, 104, 108.
 Pith-ball telegraph, 29.
 Pitch of coils in armature windings, 151.
 Pixii, Hyppolyte, 38.
 Pixii's electric generator, 38.
 Planté, Gaston, 36.
 Planté's storage battery, 36.
 Plating, copper, 37, 38.
 Plugs, telephone, 369.
 Pole, alternator field, number of, 161.
 Pole line, 104.
 Pole stamping for d. c. generator, 176.
 Pole mounting of transformer, 212.
 Poles for transmission lines, 104.
 Poles in d. c. generators, number of, 175.
 Poles, spacing of, 104.
 Polyphase circuits, 121.

- Polyphase circuits, balancing phases in, 188.
 Polyphase circuits, transformers on, 213.
 Polyphase motors, 266.
 Polyphase motor starting, 289.
 Porcelain for line insulators, 105.
 Porcelain as a dielectric, 98.
 Portable electro-dynamometers, 334.
 Power, A. C., 119.
 Power curve of shunt motor, 284, 285.
 Power, C. G. S. unit of electric, 69.
 Power curve of induction motor, 282.
 Power diagram of the steam engine, 115.
 Power, electrical, 56.
 Power factor, 120.
 Power factor indicator or meter, 351.
 Power factor, problems in, 121.
 Power generation, electric, 38.
 Power, instruments for measuring, 347.
 Power station construction, examples of, 226.
 Power station, telephone, 371.
 Power station of Cornell University, 236.
 Power station of Niagara Falls H. P. & M. Co., 241.
 Power station, impulse wheel, 236.
 Power station characteristics, 253.
 Power station, Detroit Edison Co., 230.
 Power station economics, 258.
 Power station load curves, 253.
 Power station, Long Island R.R. Co., 233.
 Power station records, 258.
 Power station, Winona Ry. Co., 226.
 Power stations, instruments in, 330.
 Power stations, reciprocating steam engine, 226.
 Power stations, construction and operation of, 217.
 Power stations, cost of operating, 260.
 Power stations, definition of, 217.
 Power stations, electrical auxiliaries in, 219.
 Power stations, elements of, 218.
 Power stations, effect on load factor on, 261.
 Power stations, electric generators in, 218.
 Power stations at Niagara Falls, 240.
 Power stations, functions of, 253.
 Power stations, gas engine, 244.
 Power stations, hydro-electric, 236.
 Power stations, lightning arresters in, 220.
 Power stations, load factor in, 253.
 Power stations, lightning protection in, 219.
 Power stations, maximum demand on, 261.
 Power stations, operation of, 253.
 Power stations, storage batteries in, 219, 247.
 Power stations, source of power in, 218.
 Power stations, switchboards in, 219.
 Power stations, steam turbine, 230.
 Power stations, water turbine, 240.
 Power transmission, electric, 38, 41.
 Power transmission, examples of, 2.
 Power transmission, summary of development of, 50.
 Power, unit of electrical, 61.
 Practical system of units, 58.
 Preparation, period of scientific, 18, 19.
 Priestly, historical work, 18.
 Primary cell, the first, 23.
 Primary coils of transformer, 196.
 Primary of induction motor, 270.
 Printing telegraph receivers, 361.
 Production of heat, 14.
 Production of light, 4.
 Properties of alloys, 78.
 Properties of conducting materials, 80.
 Properties of electric circuits, 70.
 Properties of electric circuits, 113.
 Properties of dielectrics, electrical, 96.
 Properties of magnetic materials, 88.
 Properties of materials, electrical, 72.
 Protecting motors against overload, 301.
 Pulsating current, 113.

- Quadruplex telegraphy, 30, 358.
 Quantity, instruments for measuring, 342.
 Quantity of electricity, C. G. S. unit of, 68.
 Quantity meters, electric motor, 344.
 Quantity meters, electrolytic, 343.
 Quantity, unity of electrical, 62.
 Queen Elizabeth, 19.

 Radiation factor for coils, 142.
 Radiation, selective, 5.
 Railway load curve, 254.
 Railway motor, problem in resistance of, 82.
 Railway motor, view of, 277, 278.
 Railway motors, d. c., 277.
 Railway power station, typical load curve, 256.
 Railway work, a. c. motors in, 273.
 Railways, a. c. transmission for, 49.
 Railways, steel as a conductor in, 78.
 Raising transformer, 196.
 Rare metal filaments, 34.
 Rating incandescent lamps, 304.
 Ratio of transformation, 196.
 Reactance, definition of, 126.
 Reactance in motor starting, 292.
 Reactance, problems in, 129.
 Reactance with sine wave of current, 127.
 Reaction between current and field, 53.
 Reactive force between current and magnetic field, 53.
 Receiver, telephone, 365, 366.
 Receiving devices, telegraph, 359.
 Recent electric motors, 44.
 Recent developments in electric traction, 49.
 Recent improvements in electric lamps, 35.
 Reciprocating steam engine plants, 226.
 Recorder, siphon, 360.
 Records in power stations, 258.
 Rectifier, 150.
 Refining, copper, 10, 37.
 Refining of copper, electrolytic, 75.
 Register, Morse, 353, 359.
 Register, Morse telegraph, 29.
 Regulator, constant current, 205.
 Regulator (constant current) *vs.* transformer, 205.
 Regulators, battery, 250.
 Regulation data of transformers, 207.
 Regulation, A. I. E. E. definitions of, 179.
 Regulation, inherent, 178.
 Regulation in electric circuits, 112.
 Regulation of alternators, 181.
 Regulation of alternators, data on, 182.
 Regulation of c. p. transformers, 206.
 Regulation of generators, 178.
 Regulation test, conditions for, 181.
 Relay, telegraph, 12, 30.
 Reluctance, magnetic, 135.
 Repeaters, automatic, 355.
 Repeaters, telegraph, 354.
 Repulsion motor, 45, 273.
 Requisites for ammeter shunts, 336.
 Residence lighting, 320.
 Resistance, C. G. S. unit of, 69.
 Resistance, dielectric specific, 97.
 Resistance, electrical, analogous to mechanical, 71.
 Resistance, experiment to illustrate, 54.
 Resistance in electric circuits, 123.
 Resistance materials, 73.
 Resistance materials, alloys as, 74.
 Resistance of wire, 81.
 Resistance, specific, 80.
 Resistance, unit of, 59.
 Retentiveness, magnetic, 88, 91.
 Revolving armature alternator, 152.
 Revolving field alternator, 152.
 Revolving field, view of, 162.
 Rheostats, temperature rise in, 185.
 Richmond, features of Sprague system in, 48.
 Richmond, Sprague cars in, 48.
 Ring armature, 38.
 Ring armature, Gramme's, 39.
 Ringer, telephone, 365, 367.

- Roasting of copper ores, 74.
 Rocker arm or ring, 175.
 Rod, lightning, 22.
 Room warming, electric, 328.
 Rotary converter, 197.
 Rotary converter, 197, 298.
 Rotating field, 267.
 Rubber as a dielectric, 98.
 Rupturing gradient, electric pressure, 96.
- Saturation curve of alternator, 183, 184.
 Saturation curve of d. c. generator, 191.
 Saturation in d. c. field cores, 175.
 Schuckert's alternator, 40.
 Scientific preparation, period of, 18, 19.
 Scientific preparation, summary of period of, 27.
 Scientific work, exact, 22.
 Stott's data on power station operation, 260.
 Scrubber in gas plant, 246.
 Secondary coils of transformer, 196.
 Secondary or induction motor, 270, 271.
 Section switches, 103.
 Selective radiation, 15.
 Self-excitation, conditions for, 140.
 Separate excitation, 139, 150.
 Series a. c. motor applications, 299.
 Series a. c. motor characteristics, 283.
 Series a. c. motor speed control, 295.
 Series a. c. motor starting, 292.
 Series a. c. motors, 272.
 Series arc lamps, 316.
 Series d. c. armature winding, 169.
 Series d. c. motor applications, 300.
 Series d. c. motor characteristics, 285.
 Series d. c. motor curves, 286.
 Series d. c. motor speed control, 297.
 Series, d. c. motor starting, 294.
 Series d. c. motors, 277.
 Series excitation, 151.
 Series field coil in d. c. generator, 177.
- Series field coil, problem in size of wire for, 145.
 Series motor, 44.
 Series motor, a. c., 49.
 Series transformer, 196, 202.
 Series transformer characteristics, 211.
 Series turns for compounding, 147.
 Series winding or excitation, 143.
 Service connection, overhead, 103.
 Shading coils on single-phase motors, 290.
 Sheet steel, composition of, 95.
 Sheet steel, curves showing magnetic properties, 94.
 Sheet steel field cores, 163.
 Sheet steel for d. c. generator field cores, 175.
 Sheet-steel pole cores, reasons for using, 163.
 Sheet steel, properties of, 94.
 Shell-type transformer, 197, 198.
 Short-circuit curve of alternator, 183, 186.
 Short's electric car, 48.
 Shunt arc lamps, 317.
 Shunt d. c. motors, 273.
 Shunt excitation, 139, 150.
 Shunt field coil in d. c. generator, 176.
 Shunt field coil, problem in size of wire for, 143.
 Shunt field, size of wire for, 141.
 Shunt in ammeter case, 339.
 Shunt motor, 44.
 Shunt motor applications, 299.
 Shunt motor curves, 284.
 Shunt motor, elevation and section of, 275.
 Shunt motor, parts of, 276.
 Shunt motor speed control, 296.
 Shunt motor starting, 292.
 Shunt motor, view of, 274.
 Shunted multi-gap lightning arrester, 222.
 Shunts for ammeters, 335.
 Shunts, material for ammeter, 335.
 Shunts, requisites for ammeter, 336.

- Siemens & Halske electric car, 46.
 Siemens' armature, 38.
 Siemens' electro-dynamometer, 332.
 Siemens, Werner, 38.
 Silver, German, 79.
 Silver voltameter, 343.
 Simplex telegraphy, 362.
 Sine curve and space alternator e. m. f.,
 117.
 Sine curve of cross-head velocity, 116.
 Sine waves, addition of, 128.
 Single-phase circuit, 121.
 Single-phase motor starting, 290.
 Siphon recorder, 360.
 Siphon recorder, Cuttriss magnetic, 360.
 Siphon recorder, Thomson, 360.
 Six-phase circuit, 122.
 Slip curve of induction motor, 282, 283.
 Slip in induction motors, 268.
 Slot forms, alternator armature, 154.
 Slots in d. c. armatures, 169.
 Smashing point of incandescent lamps,
 309.
 Smith forging iron in magnetic meridian,
 20.
 Soft core ammeters, 331.
 Soft drawn wire, 75.
 Soft iron core, ammeters with rotating,
 341.
 Soldering, electric, 36.
 Sounder, development of telegraph,
 359.
 Sounder, telegraph, 12, 353.
 Source of power in power stations, 218.
 Sources of light, relative values of, 323.
 Special instruments, 350.
 Specific inductive capacity, 96.
 Specific resistance, 80.
 Specific resistance of dielectrics, 97.
 Specific resistances, table of, 81.
 Speed characteristics of motors, 295.
 Speed control, motor, 294.
 Speed curve of induction motor, 282,
 283.
 Speed curve of series d. c. motor,
 286.
 Speed curve of shunt motor, 284, 285.
 Speed, synchronous, 265.
 Spherical candle power, 326.
 Sprague cars in New York, 48.
 Sprague, Frank J., 46.
 Sprague's electric car, 46.
 Sprague system, features of, 48.
 Squirrel-cage secondary, 271.
 Standardization code, extracts from
 A. I. E. E., 179, 185.
 Star-connected, 3-phase winding, 158.
 Star-connection of transformers, 213.
 Starr, J. W., 33.
 Starting box, motor, 292, 301.
 Starting motors, 287.
 Steam engine, alternating quantities in,
 114.
 Steam engine indicator card, 114.
 Steam engine plants, reciprocating, 226.
 Steam turbine plants, 230.
 Steel alloys, 95.
 Steel and iron, applications as con-
 ductors, 77, 78.
 Steel as a conductor, 74, 77.
 Steel, cast, composition of, 93.
 Steel, cast, curves of magnetic proper-
 ties, 92.
 Steel, cast, for pole cores, 93.
 Steel, cast, magnetic properties of, 93.
 Steel, cast, permeability of, 89.
 Steel, cast, strength of, 94.
 Steel compared with copper, 77, 78.
 Steel, electrical or sheet, showing mag-
 netic properties of, 94.
 Steel, electrical, properties of, 94.
 Steel, high carbon, 91.
 Steel, mild, curves of magnetic proper-
 ties, 93.
 Steel sheets, composition of, 95.
 Steel sheets, annealing of, 94.
 Steel sheets, properties of, 94.
 Steel, summary of properties of, 82.
 Steinmetz flaming arc lamp, 35.
 Steinmetz's law, 90.
 Steinmetz's summary of lightning dis-
 turbances, 219.

- Steinmetz's work in dielectrics, 96.
 Step-down transformer, 196.
 Step-up transformer, 196.
 St. Joseph, Sprague cars in, 48.
 Stock tickers, 361.
 Storage batteries, capacity of, 249.
 Storage batteries, depreciation of, 252.
 Storage batteries in power stations, 219.
 Storage battery, 11.
 Storage battery, chemistry of, 249.
 Storage battery, effect on load curve of, 255.
 Storage battery, functions of, 247.
 Storage battery handling, 251.
 Storage battery in power stations, 247.
 Storage battery, lead type, 248.
 Storage battery plates, buckling of, 252.
 Storage battery, principles of the, 247.
 Storage battery, the, 36.
 Storage of electricity, 21.
 Scott or T-connection of transformers, 214.
 Straight line law in ammeters, 340.
 Strap winding for field coils, 160, 165.
 Street lighting, 321.
 Street railway motor, magnetic circuits in, 130, 131.
 Strength, dielectric, 96.
 Sturgeon, William, 26.
 Sturgeon's electro-magnets, 26.
 Subscriber's station, telephone, 367.
 Substation, Long Island R. R. Co., 235.
 Substations, definition of, 217.
 Sulphide ores of copper, 74.
 Summary of period of commercial development, 50.
 Summary of period of mystery, 27.
 Summary of period of scientific preparation, 27.
 Superheater in gas plant, 245.
 Supervisory lamps, telephone, 369.
 Surgery, electric heat in, 329.
 Surges in transmission lines, 220.
 Swan, Sir J. W., 34.
 Swan's inventions in incandescent lamps, 34.
 Switch, knife, 224.
 Switch, oil break, 224.
 Switch, telephone, 365.
 Switchboard, Niagara Falls H. P. & M. Co., 242.
 Switchboard telephone multiple, 370.
 Switchboards, 223, 225.
 Switchboards in power stations, 219.
 Switchboards, telephone, 32, 370.
 Switches for transfer purposes, 224.
 Synchronizing alternators, 187.
 Synchronous a. c. motor applications, 298.
 Synchronous motor characteristics, 281.
 Synchronous motor, mechanical analogy, 266.
 Synchronous motor, principle of, 265.
 Synchronous motor speed control, 295.
 Synchronous motor starting, 288.
 Synchronous motor, starting a, 265.
 Synchronous motors, 45, 265.
 Synchronous speed, 265.
 Table of specific resistances and temperature coefficients, 81.
 Tantalum filaments, 34, 306, 307.
 Targets, insulators as, 106.
 Telautograph, 364.
 Telegraph alphabet or code, Morse, 352.
 Telegraph circuit, 12.
 Telegraph, duplex, 356.
 Telegraph key, 12.
 Telegraph line, first, 30.
 Telegraph, Morse's recording, 29.
 Telegraph, needle, 29.
 Telegraph, pith-ball, 29.
 Telegraph receivers, printing, 361.
 Telegraph receiving devices, 359.
 Telegraph relay, 12, 30.
 Telegraph repeaters, 354.
 Telegraph sounder, 12, 353.
 Telegraph system, Wheatstone's, 29.
 Telegraph systems, early, 29.
 Telegraph, wireless, 362.
 Telegraphy, 352.

- Telegraphy, advances in, 30.
 Telegraphy, automatic, 30.
 Telegraphy, bridge duplex, 357.
 Telegraphy, differential duplex, 356.
 Telegraphy, Duplex, 30.
 Telegraphy, Edison's invention in, 30.
 Telegraphy, quadruplex, 30, 358.
 Telegraphy, simplex, 352.
 Telegraphy, summary of development of, 50.
 Telegraphy, wireless, 31.
 Telephone "A" board, 370.
 Telephone "B" board, 371.
 Telephone central offices, 370.
 Telephone distributing circuits, 372.
 Telephone exchanges, 370.
 Telephone induction coil, 365.
 Telephone jacks, 369.
 Telephone plugs, 369.
 Telephone power plant, 371.
 Telephone receiver, 365, 366.
 Telephone ringer, 365, 367.
 Telephone subscriber's station, 367.
 Telephone supervisory lamps, 369.
 Telephone system, common battery, 368.
 Telephone switch, 365.
 Telephone switchboard multiple, 370.
 Telephone switchboards, 32, 370.
 Telephone, the, 31.
 Telephone transfer system, 371.
 Telephone transmitter, 32, 365.
 Telephone trunk lines, 370.
 Telephony, principles of, 365.
 Telephony, summary of development of, 50.
 Telephony, wireless, 373.
 Telluride transmission, 41.
 Temperature coefficient, 81.
 Temperature coefficients, coefficient of, 81.
 Temperature coefficient, control of, 81.
 Temperature coefficient, use of, 142.
 Temperature rise by resistance, 142.
 Temperature rise in alternator, 183.
 Temperature rise in transformer, curves of, 210.
 Temperature rise, limiting, 185.
 Tensile strength of magnetic field, 134.
 Tesla's induction motor, 41, 45.
 Testing incandescent lamps, 304.
 Theory of Ewing, 84.
 Thomson balance, 333.
 Thomson inclined coil ammeter, 342.
 Thomson siphon recorder, 360.
 Thomson watt-hour meter, 349.
 Thomson's repulsion motor, 45, 273.
 Thomson's summary of early power transmission, 42.
 Thorium oxide, 7.
 Three-phase alternator, curves of, 183.
 Three-phase armature winding, 156.
 Three-phase transformers, 214.
 Three-phase transmission line, 122.
 Tickers, stock, 361.
 Titanium filaments, 34.
 Toronto Exposition, electric car at, 47.
 Torque curve of series d. c. motor, 285, 286.
 Torque in electric generator, problem in, 87.
 T or Scott-connection of transformers, 214.
 Tower line, 104.
 Towers, 106.
 Towers, spacing of line, 106.
 Traction, early, 45.
 Traction, electric, recent development in, 49.
 Traction, electric, summary of development of, 50.
 Train control, multiple unit, 49.
 Transfer system, telephone, 371.
 Transfer switches, 224.
 Transformation from 2- to 3-phase, 215.
 Transformation from 3- to 2-phase, 215.
 Transformation from 3 to 6-phase, 215, 216.
 Transformation from 6- to 3-phase, 215, 216.
 Transformation of energy, 15.
 Transformation of phases, 214.

- Transformation, ratio of, 196.
 Transformer characteristics, 206.
 Transformer characteristics, constant current, 211.
 Transformer characteristics, series, 211.
 Transformer coils, 198.
 Transformer coils, insulation of, 95, 200.
 Transformer, constant current, 197, 203.
 Transformer, constant current, view of, 204.
 Transformer (constant current) *vs.* regulator, 205.
 Transformer, constant potential, 196, 197.
 Transformer construction, 195.
 Transformer core, 133.
 Transformer core loss current, 210.
 Transformer, core type, 197.
 Transformer cores, 198.
 Transformer, curves of temperature rise in, 210.
 Transformer, Deri's, 40.
 Transformer efficiency, 208.
 Transformer efficiency, all-day, 210.
 Transformer efficiency, curve of, 209.
 Transformer excitation, 137.
 Transformer, Gaulard and Gibbs, 40.
 Transformer heating, 209.
 Transformer installation, 212.
 Transformer losses, curves of, 208.
 Transformer, lowering, 196.
 Transformer magnetizing current, 210.
 Transformer, mounting upon pole, 212.
 Transformer oil, 100.
 Transformer, primary and secondary of, 196.
 Transformer, principles of the, 195.
 Transformer, principles of the modern, 196.
 Transformer, raising, 196.
 Transformer regulation, 206.
 Transformer regulation data, 207.
 Transformer, series, 196, 202.
 Transformer, shell type, 197, 198.
 Transformer, step-down, 196.
 Transformer, step-up, 196.
 Transformer, the, 40.
 Transformer, the first, 195.
 Transformer ventilation, 200.
 Transformer, Westinghouse, 40.
 Transformer winding connections, 200.
 Transformer, Zipernowski's, 40.
 Transformers and their applications, 195.
 Transformers as fire risks, 213.
 Transformers, auto or single coil, 202.
 Transformers, current, 202.
 Transformers, delta or mesh connection of, 213.
 Transformers, exciting current in c. p., 209.
 Transformers from lightning, protecting, 201.
 Transformers, grounding of neutral of, 213.
 Transformers in motor starting, 289, 292.
 Transformers, installation of, 104.
 Transformers, losses in, 200.
 Transformers, losses in c. p., 207.
 Transformers, magnetic leakage in, 199.
 Transformers, oil insulated and air blast, 199.
 Transformers on polyphase circuits, 213.
 Transformers, 3-phase, 214.
 Transformers, Scott- or T-connection of, 214.
 Transformers, summary of essentials, 199.
 Transformers, temperature rise in, 185.
 Transformers, varieties of, 196.
 Transformers, Y- or star-connection of, 213.
 Transmission at Frankfurt Exposition, 42.
 Transmission at Kassel, 41.
 Transmission at Telluride, 41.
 Transmission circuits, 103.
 Transmission, electric power, 38.
 Transmission, electric power, 41.
 Transmission from Niagara Falls, 43.
 Transmission line construction, 104.

- Transmission line, 3-phase, 122.
 Transmission line, 2-phase, 121.
 Transmission lines, iron and steel in, 77.
 Transmission lines of Ontario Power Co., 3.
 Transmission lines, poles and towers for, 104.
 Transmission of intelligence, 12, 29, 352.
 Transmission of power, summary of development of, 50.
 Transmission, summary of early power, 42.
 Transmitter, Berliner's telephone, 32.
 Transmitter, telephone, 365.
 Transmitter, the telephone, 32.
 Trolley car climbing grade, 2.
 Trunk lines, telephone, 370.
 Tube lamps, vacuum, 319.
 Tungsten, filaments, 34, 307.
 Turbine plants, water power, 240.
 Two-phase armature winding, 157.
 Two-phase, closed-coil winding, 158.
 Two-phase transmission line, 121.

 Underground conduit at Cleveland, 47.
 Underground lines, 104.
 Underwriters, National Board of Fire, 102.
 Underwriters' National Electric Association, 102.
 Units, fundamental, 59.
 Unit of capacity, 64.
 Unit of current, 59.
 Unit of electrical quantity, 62.
 Unit of electrical energy, 61.
 Unit of electrical power, 61.
 Unit of e. m. f., 59.
 Unit of inductance, 63.
 Unit of magnetic field strength or intensity, 66.
 Unit of resistance, 59.
 Units derived, 60.
 Units, definition of, 58.
 Units in the C. G. S. system, 67.

 Vacuum tube lamp, 7, 8.
 Vacuum tube lamp applications, 322.
 Vacuum tube lamps, 319.
 Van de Poelle's electric car, 47.
 Vapor lamps, mercury, 320.
 Varieties of current, 112.
 Varieties of transformers, 196.
 Varnishes as dielectrics, 100.
 V-curves of synchronous motors, 281.
 Velocity, sine curve of cross-head, 116.
 Ventilation of armatures, 160, 162.
 Ventilation of field magnets, 164.
 Ventilation of transformers, 200.
 Vertical steam turbine plants, 230.
 Volta, Alessandro, 23.
 Volta pile, in vention of, 23.
 Voltmeters, copper and silver, 343.
 Volt, C. G. S., definition of, 68.
 Volt, definition of, 59.
 Volt-ampere, definition of, 61.
 Volt-ampere-second, definition of, 61.
 Voltmeters as ground detectors, 223.
 Voltmeters, electrostatic, 344.
 Voltmeters, high resistance ammeter, 346.
 Voltmeters, hot wire, 347.
 Voltmeters, milli, 346.
 Voltmeter multipliers, 346.
 Von Hefner Alteneck's alternator, 40.

 Warming, electric room and car, 36.
 Washer in gas plant, 246.
 Water-box, 80.
 Watt, C. G. S., definition of, 69.
 Watt, definition of, 61.
 Watt-hour, definition of, 61.
 Watt-hour, meter Thomson, 394.
 Watt-second, definition of, 61.
 Wattmeters, 347.
 Wave of alternator e. m. f., 117.
 Wave winding, diagram of, 170.
 Wave winding for d. c. armatures, 169.
 Waves, Hertzian, 31.
 Waxes as dielectrics, 100.
 Welding, electric, 329.

- Welsbach gas mantle, 7.
Westinghouse alternator, 40.
Westinghouse alternator, view of, 152.
Westinghouse magnetic brake, 132, 133.
Westinghouse transformer, 40.
Weston, work on electric generator, 39.
Weston ammeter, 338.
Wheatstone duplex, 357.
Wheatstone, Sir Charles, 29.
Wheatstone's telegraph system, 29.
Wheatstone's invention of self-excitation, 38.
Wilde's magneto-exciter, 38.
Windings for alternator armatures, 156.
Winona Ry. Co., power station of, 226.
Wire, aluminum, 76.
Wire gages, 83.
Wire manufacture, copper, 75.
Wire, resistance of, 81.
Wire table, Inside back cover.
Wires, insulation of, 95.
Wiring, indoor, 108.
Wiring, Long Island R. R. Co. plant, 235.
Wireless telegraphy, 31, 362.
Wireless telephony, 373.
Wireless telegraph aerial, 363.
Wireless telegraph coherer, 363.
Wrought iron, in electrical machinery, 95.
Yarn as a dielectric, 100.
Y-connected, 3-phase winding, 158.
Y-connection of transformers, 213.
Zipernowski's alternator, 40.
Zipernowski's transformer, 40.

SHORT-TITLE CATALOGUE

OF THE

PUBLICATIONS

OF

JOHN WILEY & SONS,

NEW YORK.

LONDON: CHAPMAN & HALL, LIMITED.

ARRANGED UNDER SUBJECTS.

Descriptive circulars sent on application. Books marked with an asterisk (*) are sold at *net* prices only. All books are bound in cloth unless otherwise stated.

AGRICULTURE.

Armsby's Manual of Cattle-feeding.	12mo,	\$1 75
Principles of Animal Nutrition.	8vo,	4 00
Budd and Hansen's American Horticultural Manual:		
Part I. Propagation, Culture, and Improvement.	12mo,	1 50
Part II. Systematic Pomology.	12mo,	1 50
Elliott's Engineering for Land Drainage.	12mo,	1 50
Practical Farm Drainage.	12mo,	1 00
Graves's Forest Mensuration.	8vo,	4 00
Green's Principles of American Forestry.	12mo,	1 50
Grottenfelt's Principles of Modern Dairy Practice. (Woll.)	12mo,	2 00
Hanausek's Microscopy of Technical Products. (Winton.)	8vo,	5 00
Herrick's Denatured or Industrial Alcohol	8vo,	4 00
Maynard's Landscape Gardening as Applied to Home Decoration.	12mo,	1 50
* McKay and Larsen's Principles and Practice of Butter-making	8vo,	1 50
Sanderson's Insects Injurious to Staple Crops.	12mo,	1 50
* Schwarz's Longleaf Pine in Virgin Forest	12mo,	1 25
Stockbridge's Rocks and Soils.	8vo,	2 50
Winton's Microscopy of Vegetable Foods.	8vo,	7 50
Woll's Handbook for Farmers and Dairymen.	16mo,	1 50

ARCHITECTURE.

Baldwin's Steam Heating for Buildings.	12mo,	2 50
Bashore's Sanitation of a Country House.	12mo,	1 00
Berg's Buildings and Structures of American Railroads.	4to,	5 00
Birkmire's Planning and Construction of American Theatres.	8vo,	3 00
Architectural Iron and Steel.	8vo,	3 50
Compound Riveted Girders as Applied in Buildings.	8vo,	2 00
Planning and Construction of High Office Buildings.	8vo,	3 50
Skeleton Construction in Buildings.	8vo,	3 00
Brigg's Modern American School Buildings.	8vo,	4 00
Carpenter's Heating and Ventilating of Buildings.	8vo,	4 00

Freitag's Architectural Engineering.	8vo.	3 50
Fireproofing of Steel Buildings.	8vo.	2 50
French and Ives's Stereotomy.	8vo.	2 50
Gerhard's Guide to Sanitary House-inspection.	16mo,	1 00
Sanitation of Public Buildings	12mo,	1 50
Theatre Fires and Panics.	12mo,	1 50
*Greene's Structural Mechanics	8vo,	2 50
Holly's Carpenters' and Joiners' Handbook.	18mo,	75
Johnson's Statics by Algebraic and Graphic Methods.	8vo,	2 00
Kellaway's How to Lay Out Suburban Home Grounds.	8vo,	2 00
Kidder's Architects' and Builders' Pocket-book. Rewritten Edition.	16mo, mor.,	5 00
Merrill's Stones for Building and Decoration.	8vo,	5 00
Non-metallic Minerals: Their Occurrence and Uses.	8vo,	4 00
Monckton's Stair-building.	4to,	4 00
Patton's Practical Treatise on Foundations.	8vo,	5 00
Peabody's Naval Architecture	8vo,	7 50
Rice's Concrete-block Manufacture	8vo,	2 00
Richey's Handbook for Superintendents of Construction.	16mo, mor.,	4 00
* Building Mechanics' Ready Reference Book:		
* Carpenters' and Woodworkers' Edition.	16mo, morocco,	1 50
* Cementworkers and Plasterer's Edition. (In Press.)		
* Stone- and Brick-mason's Edition.	12mo, mor.,	1 50
Sabin's Industrial and Artistic Technology of Paints and Varnish.	8vo,	3 00
Siebert and Biggin's Modern Stone-cutting and Masonry.	8vo,	1 50
Snow's Principal Species of Wood.	8vo,	3 50
Sondericker's Graphic Statics with Applications to Trusses, Beams, and Arches.	8vo,	2 00
Towne's Locks and Builders' Hardware.	18mo, morocco,	3 00
Turneure and Maurer's Principles of Reinforced Concrete Construction.	8vo,	3 00
Wait's Engineering and Architectural Jurisprudence	8vo,	6 00
Law of Operations Preliminary to Construction in Engineering and Architecture.	8vo,	5 00
Sheep,	5 50	
Law of Contracts.	8vo,	3 00
Wilson's Air Conditioning, (In Press.)		
Wood's Rustless Coatings: Corrosion and Electrolysis of Iron and Steel.	8vo,	4 00
Worcester and Atkinson's Small Hospitals, Establishment and Maintenance, Suggestions for Hospital Architecture, with Plans for a Small Hospital.	12mo,	1 25
The World's Columbian Exposition of 1893.	Large 4to,	1 00

ARMY AND NAVY.

Bernadou's Smokeless Powder, Nitro-cellulose, and the Theory of the Cellulose Molecule.	12mo,	2 50
Chase's Screw Propellers and Marine Propulsion.	8vo,	3 00
Cloke's Gunner's Examiner.	8vo,	1 50
Craig's Azimuth.	4to,	3 50
Crehore and Squier's Polarizing Photo-chronograph.	8vo,	3 00
* Davis's Elements of Law.	8vo,	2 50
* Treatise on the Military Law of United States.	8vo,	7 00
Sheep,	7 50	
De Brack's Cavalry Outposts Duties. (Carr.)	24mo, morocco,	2 00
Dietz's Soldier's First Aid Handbook.	16mo, morocco,	1 25
* Dudley's Military Law and the Procedure of Courts-martial.	Large 12mo,	2 50
Durand's Resistance and Propulsion of Ships.	8vo,	5 00

* Dyer's Handbook of Light Artillery.	12mo,	3 00
Eissler's Modern High Explosives.	8vo,	4 00
* Fiebeger's Text-book on Field Fortification.	Small 8vo,	2 00
Hamilton's The Gunner's Catechism	18mo,	1 00
* Hoff's Elementary Naval Tactics.	8vo,	1 50
Ingalls's Handbook of Problems in Direct Fire.	8vo,	4 00
* Lissak's Ordnance and Gunnery.	8vo,	6 00
* Lyons's Treatise on Electromagnetic Phenomena. Vols. I. and II.	8vo, each,	6 00
* Mahan's Permanent Fortifications. (Mercur.)	8vo, half morocco,	7 50
Manual for Courts-martial.	16mo, morocco,	1 50
* Mercur's Attack of Fortified Places.	12mo,	2 00
* Elements of the Art of War.	8vo,	4 00
Metcalf's Cost of Manufactures—And the Administration of Workshops.	8vo,	5 00
* Ordnance and Gunnery. 2 vols.	12mo,	5 00
Murray's Infantry Drill Regulations.	18mo, paper,	10
Nixon's Adjutants' Manual.	24mo,	1 00
Peabody's Naval Architecture.	8vo,	7 50
* Phelps's Practical Marine Surveying.	8vo,	2 50
Powell's Army Officer's Examiner.	12mo,	4 00
Sharpe's Art of Subsisting Armies in War.	18mo, morocco,	1 50
* Tupes and Poole's Manual of Bayonet Exercises and Musketry Fencing.	24mo, leather,	50
Weaver's Military Explosives.	8vo,	3 00
Wheeler's Siege Operations and Military Mining.	8vo,	2 00
Winthrop's Abridgment of Military Law.	12mo,	2 50
Woodhull's Notes on Military Hygiene.	16mo,	1 50
Young's Simple Elements of Navigation.	16mo, morocco,	2 00

ASSAYING.

Fletcher's Practical Instructions in Quantitative Assaying with the Blowpipe.	12mo, morocco,	1 50
Furman's Manual of Practical Assaying.	8vo,	3 00
Lodge's Notes on Assaying and Metallurgical Laboratory Experiments.	8vo,	3 00
Low's Technical Methods of Ore Analysis.	8vo,	3 00
Miller's Manual of Assaying.	12mo,	1 00
Cyanide Process.	12mo,	1 00
Minet's Production of Aluminum and its Industrial Use. (Waldo.)	12mo,	2 50
O'Driscoll's Notes on the Treatment of Gold Ores.	8vo,	2 00
Ricketts and Miller's Notes on Assaying.	8vo,	3 00
Robine and Lenglen's Cyanide Industry. (Le Clerc.)	8vo,	4 00
Ulke's Modern Electrolytic Copper Refining.	8vo,	3 00
Wilson's Cyanide Processes.	12mo,	1 50
Chlorination Process.	12mo,	1 50

ASTRONOMY.

Comstock's Field Astronomy for Engineers.	8vo,	2 50
Craig's Azimuth.	4to,	3 50
Crandall's Text-book on Geodesy and Least Squares.	8vo,	3 00
Deolittle's Treatise on Practical Astronomy.	8vo,	4 00
Gore's Elements of Geodesy.	8vo,	2 50
Hayford's Text-book of Geodetic Astronomy.	8vo,	3 00
Merriman's Elements of Precise Surveying and Geodesy.	8vo,	2 50
* Michie and Harlow's Practical Astronomy.	8vo,	3 00
* White's Elements of Theoretical and Descriptive Astronomy	12mo,	2 00

BOTANY.

Davenport's Statistical Methods, with Special Reference to Biological Variation.	16mo, morocco, 1 25
Thomé and Bennett's Structural and Physiological Botany.....	16mo, 2 25
Westermaier's Compendium of General Botany. (Schneider.).....	8vo, 2 00

CHEMISTRY.

* Abegg's Theory of Electrolytic Dissociation. (Von Ende.).....	12mo, 1 25
Adriance's Laboratory Calculations and Specific Gravity Tables.....	12mo, 1 25
Alexeyeff's General Principles of Organic Synthesis. (Mathews.).....	8vo, 3 00
Allen's Tables for Iron Analysis.	8vo, 3 00
Arnold's Compendium of Chemistry. (Mandel.).....	Small 8vo, 3 50
Austen's Notes for Chemical Students.....	12mo, 1 50
Beard's Mine Gases and Explosions. (In Press.)	
Bernadou's Smokeless Powder.—Nitro-cellulose, and Theory of the Cellulose Molecule.....	12mo, 2 50
Bolduan's Immune Sera.....	12mo, 1 50
* Browning's Introduction to the Rarer Elements.....	8vo, 1 50
Brush and Penfield's Manual of Determinative Mineralogy.....	8vo, 4 00
* Claassen's Beet-sugar Manufacture. (Hall and Rolfe.).....	8vo, 3 00
Classen's Quantitative Chemical Analysis by Electrolysis. (Boltwood.).....	8vo, 3 00
Cohn's Indicators and Test-papers.....	12mo, 2 00
Tests and Reagents.....	8vo, 3 00
Crafts's Short Course in Qualitative Chemical Analysis. (Schaeffer.).....	12mo, 1 50
* Danneel's Electrochemistry. (Merriam.).....	12mo, 1 25
Dolezalek's Theory of the Lead Accumulator (Storage Battery). (Von Ende.).....	12mo, 2 50
Drechsel's Chemical Reactions. (Merrill.).....	12mo, 1 25
Duhem's Thermodynamics and Chemistry. (Burgess.).....	8vo, 4 00
Eissler's Modern High Explosives.....	8vo, 4 00
Effront's Enzymes and their Applications. (Prescott.).....	8vo, 3 00
Erdmann's Introduction to Chemical Preparations. (Dunlap.).....	12mo, 1 25
* Fischer's Physiology of Alimentation.....	Large 12mo, 2 00
Fletcher's Practical Instructions in Quantitative Assaying with the Blowpipe.	12mo, morocco, 1 50
Fowler's Sewage Works Analyses.....	12mo, 2 00
Fresenius's Manual of Qualitative Chemical Analysis. (Wells.).....	8vo, 5 00
Manual of Qualitative Chemical Analysis. Part I. Descriptive. (Wells.)	8vo, 3 00
Quantitative Chemical Analysis. (Cohn.) 2 vols.....	8vo, 12 50
Fuertes's Water and Public Health.....	12mo, 1 50
Furman's Manual of Practical Assaying.....	8vo, 3 00
* Getman's Exercises in Physical Chemistry.....	12mo, 2 00
Gill's Gas and Fuel Analysis for Engineers.....	12mo, 1 25
* Gooch and Browning's Outlines of Qualitative Chemical Analysis. Small	8vo, 1 25
Grotenfelt's Principles of Modern Dairy Practice. (Woll.).....	12mo, 2 00
Groth's Introduction to Chemical Crystallography (Marshall).....	12mo, 1 25
Hammarsten's Text-book of Physiological Chemistry. (Mandel.).....	8vo, 4 00
Hanausek's Microscopy of Technical Products. (Winton.).....	8vo, 5 00
* Haskin's and MacLeod's Organic Chemistry.....	12mo, 2 00
Helm's Principles of Mathematical Chemistry. (Morgan.).....	12mo, 1 50
Hering's Ready Reference Tables (Conversion Factors).....	16mo, morocco, 2 50
Herrick's Denatured or Industrial Alcohol.....	8vo, 4 00
Hind's Inorganic Chemistry.....	8vo, 3 00
* Laboratory Manual for Students.....	12mo, 1 00
Holleman's Text-book of Inorganic Chemistry. (Cooper.).....	8vo, 2 50
Text-book of Organic Chemistry. (Walker and Mott.).....	8vo, 2 50
* Laboratory Manual of Organic Chemistry. (Walker.).....	12mo, 1 00

Holley and Ladd's Analysis of Mixed Paints, Color Pigments, and Varnishes. (In Press)		
Hopkins's Oil-chemists' Handbook.....	8vo,	3 00
Iddings's Rock Minerals.....	8vo,	5 00
Jackson's Directions for Laboratory Work in Physiological Chemistry..	8vo,	1 25
Johannsen's Key for the Determination of Rock-forming Minerals in Thin Sections. (In Press)		
Keep's Cast Iron.....	8vo,	2 50
Ladd's Manual of Quantitative Chemical Analysis.....	12mo,	1 00
Landauer's Spectrum Analysis. (Tingle.).....	8vo,	3 00
* Langworthy and Austen. The Occurrence of Aluminium in Vegetable Products, Animal Products, and Natural Waters.....	8vo,	2 00
Lassar-Cohn's Application of Some General Reactions to Investigations in Organic Chemistry. (Tingle.).....	12mo,	1 00
Leach's The Inspection and Analysis of Food with Special Reference to State Control.....	8vo,	7 50
Löb's Electrochemistry of Organic Compounds. (Lorenz.).....	8vo,	3 00
Lodge's Notes on Assaying and Metallurgical Laboratory Experiments... ..	8vo,	3 00
Low's Technical Method of Ore Analysis.....	8vo,	3 00
Lunge's Techno-chemical Analysis. (Cohn.).....	12mo	1 00
* McKay and Larsen's Principles and Practice of Butter-making.....	8vo,	1 50
Maire's Modern Pigments and their Vehicles. (In Press.)		
Mandel's Handbook for Bio-chemical Laboratory.....	12mo,	1 50
* Martin's Laboratory Guide to Qualitative Analysis with the Blowpipe..	12mo,	60
Mason's Water-supply. (Considered Principally from a Sanitary Standpoint.) 3d Edition, Rewritten.....	8vo,	4 00
Examination of Water. (Chemical and Bacteriological.).....	12mo,	1 25
Matthew's The Textile Fibres. 2d Edition, Rewritten.....	8vo,	4 00
Meyer's Determination of Radicles in Carbon Compounds. (Tingle.)..	12mo,	1 00
Miller's Manual of Assaying.....	12mo,	1 00
Cyanide Process.....	12mo,	1 00
Minet's Production of Aluminum and its Industrial Use. (Waldo.).....	12mo,	2 50
Mixer's Elementary Text-book of Chemistry.....	12mo,	1 50
Morgan's An Outline of the Theory of Solutions and its Results.....	12mo,	1 00
Elements of Physical Chemistry.....	12mo,	3 00
* Physical Chemistry for Electrical Engineers.....	12mo,	5 00
Morse's Calculations used in Cane-sugar Factories.....	16mo, morocco,	1 50
* Muir's History of Chemical Theories and Laws.....	8vo,	4 00
Mulliken's General Method for the Identification of Pure Organic Compounds. Vol. I.....	Large 8vo,	5 00
O'Driscoll's Notes on the Treatment of Gold Ores.....	8vo,	2 00
Ostwald's Conversations on Chemistry. Part One. (Ramsey.).....	12mo,	1 50
" " " " Part Two. (Turnbull.).....	12mo,	2 00
* Palmer's Practical Test Book of Chemistry.....	12mo,	1 00
* Pauli's Physical Chemistry in the Service of Medicine. (Fischer.).....	12mo,	1 25
* Penfield's Notes on Determinative Mineralogy and Record of Mineral Tests. 8vo, paper,		50
Pictet's The Alkaloids and their Chemical Constitution. (Biddle.).....	8vo,	5 00
Pinner's Introduction to Organic Chemistry. (Austen.).....	12mo,	1 50
Poole's Calorific Power of Fuels.....	8vo,	3 00
Prescott and Winslow's Elements of Water Bacteriology, with Special Reference to Sanitary Water Analysis.....	12mo,	1 25
* Reisig's Guide to Piece-dyeing.....	8vo,	25 00
Richards and Woodman's Air, Water, and Food from a Sanitary Standpoint..	8vo,	2 00
Ricketts and Miller's Notes on Assaying.....	8vo,	3 00
Rideal's Sewage and the Bacterial Purification of Sewage.....	8vo,	4 00
Disinfection and the Preservation of Food.....	8vo,	4 00
Riggs's Elementary Manual for the Chemical Laboratory.....	8vo,	1 25
Robine and Lenglen's Cyanide Industry. (Le Clerc.).....	8vo,	4 00

Hering's Ready Reference Tables (Conversion Factors)	16mo, morocco,	2 50
Howe's Retaining Walls for Earth.	12mo,	1 25
Hoyt and Grover's River Discharge.	8vo,	2 00
* Ives's Adjustments of the Engineer's Transit and Level.	16mo, Bds.	25
Ives and Hilts's Problems in Surveying.	16mo, morocco,	1 50
Johnson's (J. B.) Theory and Practice of Surveying.	Small 8vo,	4 00
Johnson's (L. J.) Statics by Algebraic and Graphic Methods.	8vo,	2 00
Laplace's Philosophical Essay on Probabilities. (Truscott and Emory.)	12mo,	2 00
Mahan's Treatise on Civil Engineering. (1873.) (Wood.)	8vo,	5 00
* Descriptive Geometry.	8vo,	1 50
Merriman's Elements of Precise Surveying and Geodesy.	8vo,	2 50
Merriman and Brooks's Handbook for Surveyors.	16mo, morocco,	2 00
Nugent's Plane Surveying.	8vo,	3 50
Ogden's Sewer Design.	12mo,	2 00
Parsons's Disposal of Municipal Refuse.	8vo,	2 00
Patton's Treatise on Civil Engineering.	8vo half leather,	7 50
Reed's Topographical Drawing and Sketching	4to,	5 00
Rideal's Sewage and the Bacterial Purification of Sewage.	8vo,	4 00
Riemer's Shaft-sinking under Difficult Conditions. (Corning and Peele.)	8vo,	3 00
Siebert and Biggin's Modern Stone-cutting and Masonry.	8vo,	1 50
Smith's Manual of Topographical Drawing. (McMillan.)	8vo,	2 50
Sondericker's Graphic Statics, with Applications to Trusses, Beams, and Arches.	8vo,	2 00
Taylor and Thompson's Treatise on Concrete, Plain and Reinforced.	8vo,	5 00
Tracy's Plane Surveying.	16mo, morocco,	3 00
* Trautwine's Civil Engineer's Pocket-book.	16mo, morocco,	5 00
Venable's Garbage Crematories in America.	8vo,	2 00
Wait's Engineering and Architectural Jurisprudence.	8vo,	6 00
	Sheep,	6 50
Law of Operations Preliminary to Construction in Engineering and Archi- tecture.	8vo,	5 00
	Sheep,	5 50
Law of Contracts.	8vo,	3 00
Warren's Stereotomy—Problems in Stone-cutting.	8vo,	2 50
Webb's Problems in the Use and Adjustment of Engineering Instruments.	16mo, morocco,	1 25
Wilson's Topographic Surveying.	8vo,	3 50

BRIDGES AND ROOFS.

Boller's Practical Treatise on the Construction of Iron Highway Bridges.	8vo,	2 00
Burr and Falk's Influence Lines for Bridge and Roof Computations.	8vo,	3 00
Design and Construction of Metallic Bridges	8vo,	5 00
Du Bois's Mechanics of Engineering. Vol. II.	Small 4to,	10 00
Foster's Treatise on Wooden Trestle Bridges.	4to,	5 00
Fowler's Ordinary Foundations.	8vo,	3 50
Greene's Roof Trusses.	8vo,	1 25
Bridge Trusses.	8vo,	2 50
Arches in Wood, Iron, and Stone.	8vo,	2 50
Grimm's Secondary Stresses in Bridge Trusses. (In Press.)		
Howe's Treatise on Arches.	8vo,	4 00
Design of Simple Roof-trusses in Wood and Steel.	8vo,	2 00
Symmetrical Masonry Arches.	8vo,	2 50
Johnson, Bryan, and Turneure's Theory and Practice in the Designing of Modern Framed Structures.	Small 4to,	10 00
Merriman and Jacoby's Text-book on Roofs and Bridges:		
Part I. Stresses in Simple Trusses.	8vo,	2 50
Part II. Graphic Statics.	8vo,	2 50
Part III. Bridge Design.	8vo,	2 50
Part IV. Higher Structures	8vo,	2 50

Morison's Memphis Bridge.	4to,	10 00
Waddell's De Pontibus, a Pocket-book for Bridge Engineers.	16mo, morocco,	2 00
* Specifications for Steel Bridges.	12mo,	50
Wright's Designing of Draw-spans. Two parts in one volume.	8vo,	3 50

HYDRAULICS.

Barnes's Ice Formation.	8vo,	3 00
Bazin's Experiments upon the Contraction of the Liquid Vein Issuing from an Orifice. (Trautwine.)	8vo,	2 00
Bovey's Treatise on Hydraulics.	8vo,	5 00
Church's Mechanics of Engineering.	8vo,	6 00
Diagrams of Mean Velocity of Water in Open Channels.	paper,	1 50
Hydraulic Motors.	8vo,	2 00
Coffin's Graphical Solution of Hydraulic Problems.	16mo, morocco,	2 50
Fletcher's Dynamometers, and the Measurement of Power.	12mo,	3 00
Folwell's Water-supply Engineering.	8vo,	4 00
Frizell's Water-power.	8vo,	5 00
Fuertes's Water and Public Health.	12mo,	1 50
Water-filtration Works.	12mo,	2 50
Ganguillet and Kutter's General Formula for the Uniform Flow of Water in Rivers and Other Channels. (Hering and Trautwine.)	8vo,	4 00
Hazen's Clean Water and How to Get It.	Large 12mo,	1 50
Filtration of Public Water-supply.	8vo,	3 00
Hazlehurst's Towers and Tanks for Water-works.	8vo,	2 50
Herschel's 115 Experiments on the Carrying Capacity of Large, Riveted, Metal Conduits.	8vo,	2 00
* Hubbard and Kiersted's Water-works Management and Maintenance.	8vo,	4 00
Mason's Water-supply. (Considered Principally from a Sanitary Standpoint.)	8vo,	4 00
Merriman's Treatise on Hydraulics.	8vo,	5 00
* Michie's Elements of Analytical Mechanics.	8vo,	4 00
Schuyler's Reservoirs for Irrigation, Water-power, and Domestic Water-supply.	Large 8vo,	5 00
* Thomas and Watt's Improvement of Rivers.	4to,	6 00
Turneure and Russell's Public Water-supplies	8vo,	5 00
Wegmann's Design and Construction of Dams. 5th Edition, enlarged.	4to,	6 00
Water-supply of the City of New York from 1658 to 1895.	4to,	10 00
Whipple's Value of Pure Water	Large 12mo,	1 00
Williams and Hazen's Hydraulic Tables.	8vo,	1 50
Wilson's Irrigation Engineering.	Small 8vo,	4 00
Wolff's Windmill as a Prime Mover.	8vo,	3 00
Wood's Turbines.	8vo,	2 50
Elements of Analytical Mechanics.	8vo,	3 00

MATERIALS OF ENGINEERING.

Baker's Treatise on Masonry Construction.	8vo,	5 00
Roads and Pavements.	8vo,	5 00
Black's United States Public Works	Oblong 4to,	5 00
* Bovey's Strength of Materials and Theory of Structures.	8vo,	7 50
Burr's Elasticity and Resistance of the Materials of Engineering.	8vo,	7 50
Byrne's Highway Construction.	8vo,	5 00
Inspection of the Materials and Workmanship Employed in Construction.	16mo,	3 00
Church's Mechanics of Engineering.	8vo,	6 00
Du Bois's Mechanics of Engineering. Vol. I.	Small 4to	7 50
*Eckel's Cements, Limes, and Plasters	8vo,	6 00

Johnson's Materials of Construction.	Large 8vo,	6 00
Fowler's Ordinary Foundations.	8vo,	3 50
Graves's Forest Mensuration.	8vo,	4 00
* Greene's Structural Mechanics.	8vo,	2 50
Keep's Cast Iron.	8vo,	2 50
Lanza's Applied Mechanics.	8vo,	7 50
Martens's Handbook on Testing Materials. (Henning.) 2 vols.	8vo,	7 50
Maurer's Technical Mechanics.	8vo,	4 00
Merrill's Stones for Building and Decoration.	8vo,	5 00
Merriman's Mechanics of Materials.	8vo,	5 00
* Strength of Materials	12mo,	1 00
Metcalf's Steel. A Manual for Steel-users.	12mo,	2 00
Patton's Practical Treatise on Foundations.	8vo,	5 00
Richardson's Modern Asphalt Pavements	8vo,	3 00
Richey's Handbook for Superintendents of Construction.	16mo, mor.,	4 00
* Ries's Clays: Their Occurrence, Properties, and Uses.	8vo,	5 00
Rockwell's Roads and Pavements in France.	12mo,	1 25
Sabin's Industrial and Artistic Technology of Paints and Varnish.	8vo,	3 00
* Schwarz's Longleaf Pine in Virgin Forest	12mo,	1 25
Smith's Materials of Machines.	12mo,	1 00
Snow's Principal Species of Wood.	8vo,	3 50
Spalding's Hydraulic Cement.	12mo,	2 00
Text-book on Roads and Pavements.	12mo,	2 00
Taylor and Thompson's Treatise on Concrete, Plain and Reinforced.	8vo,	5 00
Thurston's Materials of Engineering. 3 Parts.	8vo,	8 00
Part I. Non-metallic Materials of Engineering and Metallurgy.	8vo,	2 00
Part II. Iron and Steel.	8vo,	3 50
Part III. A Treatise on Brasses, Bronzes, and Other Alloys and their Constituents.	8vo,	2 50
Tilston's Street Pavements and Paving Materials.	8vo,	4 00
Turneure and Maurer's Principles of Reinforced Concrete Construction.	8vo,	3 00
Waddell's De Pontibus. (A Pocket-book for Bridge Engineers.)	16mo, mor.,	2 00
* Specifications for Steel Bridges.	12mo,	50
Wood's (De V.) Treatise on the Resistance of Materials, and an Appendix on the Preservation of Timber.	8vo,	2 00
Wood's (De V.) Elements of Analytical Mechanics.	8vo,	3 00
Wood's (M. P.) Rustless Coatings: Corrosion and Electrolysis of Iron and Steel.	8vo,	4 00

RAILWAY ENGINEERING.

Andrew's Handbook for Street Railway Engineers.	3x5 inches, morocco,	1 25
Berg's Buildings and Structures of American Railroads	4to,	5 00
Brook's Handbook of Street Railroad Location.	16mo, morocco,	1 50
Butt's Civil Engineer's Field-book.	16mo, morocco,	2 50
Crandall's Transition Curve.	16mo, morocco,	1 50
Railway and Other Earthwork Tables.	8vo,	1 50
Crookett's Methods for Earthwork Computations. (In Press)		
Dawson's "Engineering" and Electric Traction Pocket-book.	16mo, morocco	5 00
Dredge's History of the Pennsylvania Railroad: (1879).	Paper,	5 00
Fisher's Table of Cubic Yards.	Cardboard,	25
Godwin's Railroad Engineers' Field-book and Explorers' Guide.	16mo, mor.,	2 50
Hudson's Tables for Calculating the Cubic Contents of Excavations and Embankments.	8vo,	1 00
Molitor and Beard's Manual for Resident Engineers.	16mo,	1 00
Nagle's Field Manual for Railroad Engineers.	16mo, morocco,	3 00
Philbrick's Field Manual for Engineers.	16mo, morocco,	3 00
Raymond's Elements of Railroad Engineering. (In Press.)		

Searles's Field Engineering.	16mo, morocco,	3 00
Railroad Spiral.	16mo, morocco,	1 50
Taylor's Prismoïdal Formulæ and Earthwork.	8vo,	1 50
* Trautwine's Method of Calculating the Cube Contents of Excavations and Embankments by the Aid of Diagrams.	8vo,	2 00
The Field Practice of Laying Out Circular Curves for Railroads.	12mo, morocco,	2 50
Cross-section Sheet.	Paper,	25
Webb's Railroad Construction.	16mo, morocco,	5 00
Economics of Railroad Construction.	Large 12mo,	2 50
Wellington's Economic Theory of the Location of Railways.	Small 8vo,	5 00

DRAWING.

Barr's Kinematics of Machinery.	8vo,	2 50
* Bartlett's Mechanical Drawing.	8vo,	3 00
* " " " " Abridged Ed.	8vo,	1 50
Coolidge's Manual of Drawing.	8vo, paper,	1 00
Coolidge and Freeman's Elements of General Drafting for Mechanical Engineers.	Oblong 4to,	2 50
Durley's Kinematics of Machines.	8vo,	4 00
Emch's Introduction to Projective Geometry and its Applications.	8vo,	2 50
Hill's Text-book on Shades and Shadows, and Perspective.	8vo,	2 00
Jamison's Elements of Mechanical Drawing.	8vo,	2 50
Advanced Mechanical Drawing.	8vo,	2 00
Jones's Machine Design:		
Part I. Kinematics of Machinery.	8vo,	1 50
Part II. Form, Strength, and Proportions of Parts.	8vo,	3 00
MacCord's Elements of Descriptive Geometry.	8vo,	3 00
Kinematics; or, Practical Mechanism.	8vo,	5 00
Mechanical Drawing.	4to,	4 00
Velocity Diagrams.	8vo,	1 50
MacLeod's Descriptive Geometry.	Small 8vo,	1 50
* Mahan's Descriptive Geometry and Stone-cutting.	8vo,	1 50
Industrial Drawing. (Thompson.)	8vo,	3 50
Moyer's Descriptive Geometry.	8vo,	2 00
Reed's Topographical Drawing and Sketching.	4to,	5 00
Reid's Course in Mechanical Drawing.	8vo,	2 00
Text-book of Mechanical Drawing and Elementary Machine Design. 8vo,		3 00
Robinson's Principles of Mechanism.	8vo,	3 00
Schwamb and Merrill's Elements of Mechanism.	8vo,	3 00
Smith's (R. S.) Manual of Topographical Drawing. (McMillan.)	8vo,	2 50
Smith (A. W.) and Marx's Machine Design.	8vo,	3 00
* Tittsworth's Elements of Mechanical Drawing	Oblong 8vo,	1 25
Warren's Elements of Plane and Solid Free-hand Geometrical Drawing. 12mo,		1 00
Drafting Instruments and Operations.	12mo,	1 25
Manual of Elementary Projection Drawing.	12mo,	1 50
Manual of Elementary Problems in the Linear Perspective of Form and Shadow.	12mo,	1 00
Plane Problems in Elementary Geometry.	12mo,	1 25
Elements of Descriptive Geometry, Shadows, and Perspective.	8vo,	3 50
General Problems of Shades and Shadows.	8vo,	3 00
Elements of Machine Construction and Drawing.	8vo,	7 50
Problems, Theorems, and Examples in Descriptive Geometry.	8vo,	2 50
Weisbach's Kinematics and Power of Transmission. (Hermann and Klein.)	8vo,	5 00
Whelpley's Practical Instruction in the Art of Letter Engraving.	12mo,	2 00
Wilson's (H. M.) Topographic Surveying.	8vo,	3 50

Wilson's (V. T.) Free-hand Perspective.	8vo,	2 50
Wilson's (V. T.) Free-hand Lettering.	8vo,	1 00
Woolf's Elementary Course in Descriptive Geometry.	Large 8vo,	3 00

ELECTRICITY AND PHYSICS.

* Abegg's Theory of Electrolytic Dissociation. (Von Ende.)	12mo,	1 25
Anthony and Brackett's Text-book of Physics. (Magie.)	Small 8vo,	3 00
Anthony's Lecture-notes on the Theory of Electrical Measurements.	12mo,	1 00
Benjamin's History of Electricity.	8vo,	3 00
Voltaic Cell.	8vo,	3 00
Betts's Lead Refining and Electrolysis. (In Press.)		
Classen's Quantitative Chemical Analysis by Electrolysis. (Boltwood.)	8vo,	3 00
* Collins's Manual of Wireless Telegraphy.	12mo,	1 50
Morocco.		2 00
Crehore and Squier's Polarizing Photo-chronograph.	8vo,	3 00
* Danneel's Electrochemistry. (Merriam.)	12mo,	1 25
Dawson's "Engineering" and Electric Traction Pocket-book.	16mo, morocco,	5 00
Dolezalek's Theory of the Lead Accumulator (Storage Battery). (Von Ende.)		
12mo,		2 50
Duhem's Thermodynamics and Chemistry. (Burgess.)	8vo,	4 00
Flather's Dynamometers, and the Measurement of Power.	12mo,	3 00
Gilbert's De Magnete. (Mottelay.)	8vo,	2 50
Hanchett's Alternating Currents Explained.	12mo,	1 00
Hering's Ready Reference Tables (Conversion Factors).	16mo, morocco,	2 50
Hobart and Ellis's High-speed Dynamo Electric Machinery. (In Press.)		
Holman's Precision of Measurements.	8vo,	2 00
Telescopic Mirror-scale Method, Adjustments, and Tests.	Large 8vo,	75
Karapetoff's Experimental Electrical Engineering. (In Press.)		
Kinzbrunner's Testing of Continuous-current Machines.	8vo,	2 00
Landauer's Spectrum Analysis. (Tingle.)	8vo,	3 00
Le Chatelier's High-temperature Measurements. (Boudouard—Burgess.)	12mo,	3 00
Löb's Electrochemistry of Organic Compounds. (Lorenz.)	8vo,	3 00
* Lyons's Treatise on Electromagnetic Phenomena. Vols. I. and II.	8vo, each,	6 00
* Michie's Elements of Wave Motion Relating to Sound and Light.	8vo,	4 00
Niaudet's Elementary Treatise on Electric Batteries. (Fishback.)	12mo,	2 50
Norris's Introduction to the Study of Electrical Engineering. (In Press.)		
* Parshall and Hobart's Electric Machine Design.	4to, half morocco,	12 50
Reagan's Locomotives: Simple, Compound, and Electric. New Edition.		
Large 12mo,		3 50
* Rosenberg's Electrical Engineering. (Haldane Gee—Kinzbrunner.)	8vo,	2 00
Ryan, Norris, and Hoxie's Electrical Machinery. Vol. I.	8vo,	2 50
Thurston's Stationary Steam-engines.	8vo,	2 50
* Tillman's Elementary Lessons in Heat.	8vo,	1 50
Tory and Pitcher's Manual of Laboratory Physics.	Small 8vo,	2 00
Ulke's Modern Electrolytic Copper Refining.	8vo,	3 00

LAW.

* Davis's Elements of Law.	8vo,	2 50
* Treatise on the Military Law of United States.	8vo,	7 00
*	Sheep,	7 50
* Dudley's Military Law and the Procedure of Courts-martial	Large 12mo,	2 50
Manual for Courts-martial.	16mo, morocco,	1 50
Wait's Engineering and Architectural Jurisprudence.	8vo,	6 00
Sheep,		6 50
Law of Operations Preliminary to Construction in Engineering and Archi- tecture.	8vo	5 00
Sheep,		5 50
Law of Contracts.	8vo,	3 00
Winthrop's Abridgment of Military Law.	12mo,	2 50

* Johnson's (J. B.) Three-place Logarithmic Tables: Vest-pocket size . paper,	15
100 copies for	5 00
* Mounted on heavy cardboard, 8×10 inches,	25
10 copies for	2 00
Johnson's (W. W.) Elementary Treatise on Differential Calculus . Small 8vo,	3 00
Elementary Treatise on the Integral Calculus Small 8vo,	1 50
Johnson's (W. W.) Curve Tracing in Cartesian Co-ordinates 12mo,	1 00
Johnson's (W. W.) Treatise on Ordinary and Partial Differential Equations.	
Small 8vo,	3 50
Johnson's Treatise on the Integral Calculus Small 8vo,	3 00
Johnson's (W. W.) Theory of Errors and the Method of Least Squares . 12mo,	1 50
* Johnson's (W. W.) Theoretical Mechanics 12mo,	3 00
Laplace's Philosophical Essay on Probabilities. (Truscott and Emory.) . 12mo,	2 00
* Ludlow and Bass. Elements of Trigonometry and Logarithmic and Other	
Tables 8vo,	3 00
Trigonometry and Tables published separately Each,	2 00
* Ludlow's Logarithmic and Trigonometric Tables 8vo,	1 00
Manning's Irrational Numbers and their Representation by Sequences and Series	
12mo,	1 25
Mathematical Monographs. Edited by Mansfield Merriman and Robert	
S. Woodward. Octavo, each	1 00
No. 1. History of Modern Mathematics, by David Eugene Smith.	
No. 2. Synthetic Projective Geometry, by George Bruce Halsted.	
No. 3. Determinants, by Laenas Gifford Weld. No. 4. Hyper-	
bolic Functions, by James McMahon. No. 5. Harmonic Func-	
tions, by William E. Byerly. No. 6. Grassmann's Space Analysis,	
by Edward W. Hyde. No. 7. Probability and Theory of Errors,	
by Robert S. Woodward. No. 8. Vector Analysis and Quaternions,	
by Alexander Macfarlane. No. 9. Differential Equations, by	
William Woolsey Johnson. No. 10. The Solution of Equations,	
by Mansfield Merriman. No. 11. Functions of a Complex Variable,	
by Thomas S. Fiske.	
Maurer's Technical Mechanics. 8vo,	4 00
Merriman's Method of Least Squares. 8vo,	2 00
Rice and Johnson's Elementary Treatise on the Differential Calculus. Sm. 8vo,	3 00
Differential and Integral Calculus. 2 vols. in one. Small 8vo,	3 50
* Veblen and Lennes's Introduction to the Real Infinitesimal Analysis of One	
Variable 8vo,	2 00
Wood's Elements of Co-ordinate Geometry. 8vo,	2 00
Trigonometry: Analytical, Plane, and Spherical 12mo,	1 00

MECHANICAL ENGINEERING.

MATERIALS OF ENGINEERING, STEAM-ENGINES AND BOILERS.

Bacon's Forge Practice. 12mo,	1 50
Baldwin's Steam Heating for Buildings. 12mo,	2 50
Barr's Kinematics of Machinery. 8vo,	2 50
* Bartlett's Mechanical Drawing. 8vo,	3 00
* " " " Abridged Ed. 8vo,	1 50
Benjamin's Wrinkles and Recipes. 12mo,	2 00
Carpenter's Experimental Engineering. 8vo,	6 00
Heating and Ventilating Buildings. 8vo,	4 00
Clerk's Gas and Oil Engine. Small 8vo,	4 00
Coolidge's Manual of Drawing. 8vo, paper,	1 00
Coolidge and Freeman's Elements of General Drafting for Mechanical En-	
gineers. Oblong 4to,	2 50
Cromwell's Treatise on Toothed Gearing. 12mo,	1 50
Treatise on Belts and Pulleys. 12mo,	1 50

Durley's Kinematics of Machines.	8vo,	4 00
Fletcher's Dynamometers and the Measurement of Power.	12mo,	3 00
Rope Driving.	12mo,	2 00
Gill's Gas and Fuel Analysis for Engineers.	12mo,	1 25
Hall's Car Lubrication.	12mo,	1 00
Hering's Ready Reference Tables (Conversion Factors).	16mo, morocco,	2 50
Hutton's The Gas Engine.	8vo,	5 00
Jamison's Mechanical Drawing.	8vo,	2 50
Jones's Machine Design:		
Part I. Kinematics of Machinery.	8vo,	1 50
Part II. Form, Strength, and Proportions of Parts.	8vo,	3 00
Kent's Mechanical Engineers' Pocket-book.	16mo, morocco,	5 00
Kerr's Power and Power Transmission.	8vo,	2 00
Leonard's Machine Shop, Tools, and Methods.	8vo,	4 00
* Lorenz's Modern Refrigerating Machinery. (Pope, Haven, and Dean.)	8vo,	4 00
MacCord's Kinematics; or, Practical Mechanism.	8vo,	5 00
Mechanical Drawing.	4to,	4 00
Velocity Diagrams.	8vo,	1 50
MacFarland's Standard Reduction Factors for Gases.	8vo,	1 50
Mahan's Industrial Drawing. (Thompson.)	8vo,	3 50
Poole's Calorific Power of Fuels.	8vo,	3 00
Reid's Course in Mechanical Drawing.	8vo,	2 00
Text-book of Mechanical Drawing and Elementary Machine Design.	8vo,	3 00
Richard's Compressed Air	12mo,	1 50
Robinson's Principles of Mechanism.	8vo,	3 00
Schwamb and Merrill's Elements of Mechanism.	8vo,	3 00
Smith's (O.) Press-working of Metals.	8vo,	3 00
Smith (A. W.) and Marx's Machine Design.	8vo,	3 00
Thurston's Treatise on Friction and Lost Work in Machinery and Mill Work.	8vo,	3 00
Animal as a Machine and Prime Motor, and the Laws of Energetics.	12mo,	1 00
Tillson's Complete Automobile Instructor	16mo,	1 50
Morocco,		2 00
Warren's Elements of Machine Construction and Drawing.	8vo,	7 50
Weisbach's Kinematics and the Power of Transmission. (Herrmann— Klein.)	8vo,	5 00
Machinery of Transmission and Governors. (Herrmann—Klein.)	8vo,	5 00
Wolff's Windmill as a Prime Mover.	8vo,	3 00
Wood's Turbines.	8vo,	2 50

MATERIALS OF ENGINEERING.

* Bovey's Strength of Materials and Theory of Structures.	8vo,	7 50
Burr's Elasticity and Resistance of the Materials of Engineering. 6th Edition. Reset.	8vo,	7 50
Church's Mechanics of Engineering.	8vo,	6 00
* Greene's Structural Mechanics	8vo,	2 50
Johnson's Materials of Construction.	8vo,	6 00
Keep's Cast Iron.	8vo,	2 50
Lanza's Applied Mechanics.	8vo,	7 50
Martens's Handbook on Testing Materials. (Henning.)	8vo,	7 50
Maurer's Technical Mechanics.	8vo,	4 00
Merriman's Mechanics of Materials.	8vo,	5 00
* . . . Strength of Materials	12mo,	1 00
Metcalf's Steel. A Manual for Steel-users.	12mo,	2 00
Sabin's Industrial and Artistic Technology of Paints and Varnish.	8vo,	3 00
Smith's Materials of Machines.	12mo,	1 00
Thurston's Materials of Engineering.	3 vols., 8vo,	8 00
Part II. Iron and Steel.	8vo,	3 50
Part III. A Treatise on Brasses, Bronzes, and Other Alloys and their Constituents.	8vo,	2 50

Wood's (De V.) Treatise on the Resistance of Materials and an Appendix on the Preservation of Timber.8vo,	2 00
Elements of Analytical Mechanics.8vo,	3 00
Wood's (M. P.) Rustless Coatings: Corrosion and Electrolysis of Iron and Steel.8vo,	4 00

STEAM-ENGINES AND BOILERS.

Berry's Temperature-entropy Diagram.	12mo,	1 25
Carnot's Reflections on the Motive Power of Heat. (Thurston.)	12mo,	1 50
Creighton's Steam-engine and other Heat-motors.8vo,	5 00
Dawson's "Engineering" and Electric Traction Pocket-book.	16mo, mor.,	5 00
Ford's Boiler Making for Boiler Makers.	18mo,	1 00
Goss's Locomotive Sparks.8vo,	2 00
Locomotive Performance.8vo,	5 00
Hemenway's Indicator Practice and Steam-engine Economy.	12mo,	2 00
Hutton's Mechanical Engineering of Power Plants.8vo,	5 00
Heat and Heat-engines.8vo,	5 00
Kent's Steam boiler Economy.8vo,	4 00
Kneass's Practice and Theory of the Injector.8vo,	1 50
MacCord's Slide-valves.8vo,	2 00
Meyer's Modern Locomotive Construction.	4to,	10 00
Peabody's Manual of the Steam-engine Indicator.	12mo,	1 50
Tables of the Properties of Saturated Steam and Other Vapors.8vo,	1 00
Thermodynamics of the Steam-engine and Other Heat-engines.8vo,	5 00
Valve-gears for Steam-engines.8vo,	2 50
Peabody and Miller's Steam-boilers.8vo,	4 00
Pray's Twenty Years with the Indicator.	Large 8vo,	2 50
Pupin's Thermodynamics of Reversible Cycles in Gases and Saturated Vapors. (Osterberg.)	12mo,	1 25
Reagan's Locomotives: Simple, Compound, and Electric. New Edition.	Large 12mo,	3 50
Sinclair's Locomotive Engine Running and Management.	12mo,	2 00
Smart's Handbook of Engineering Laboratory Practice.	12mo,	2 50
Snow's Steam-boiler Practice.8vo,	3 00
Spangler's Valve-gears.8vo,	2 50
Notes on Thermodynamics.	12mo,	1 00
Spangler, Greene, and Marshall's Elements of Steam-engineing.8vo,	3 00
Thomas's Steam-turbines.8vo,	3 50
Thurston's Handy Tables.8vo,	1 50
Manual of the Steam-engine.	2 vols., 8vo,	10 00
Part I. History, Structure, and Theory.8vo,	6 00
Part II. Design, Construction, and Operation.8vo,	6 00
Handbook of Engine and Boiler Trials, and the Use of the Indicator and the Prony Brake.8vo,	5 00
Stationary Steam-engines.8vo,	2 50
Steam-boiler Explosions in Theory and in Practice.	12mo,	1 50
Manual of Steam-boilers, their Designs, Construction, and Operation.8vo,	5 00
Whrenfenning's Analysis and Softening of Boiler Feed-water (Patterson)	8vo,	4 00
Weisbach's Heat, Steam, and Steam-engines. (Du Bois.)8vo,	5 00
Whitham's Steam-engine Design.8vo,	5 00
Wood's Thermodynamics, Heat Motors, and Refrigerating Machines.8vo,	4 00

MECHANICS AND MACHINERY.

Barr's Kinematics of Machinery.8vo,	2 50
* Bovey's Strength of Materials and Theory of Structures.8vo,	7 50
Chase's The Art of Pattern-making.	12mo,	2 50

Church's Mechanics of Engineering.	8vo,	6 00
Notes and Examples in Mechanics.	8vo,	2 00
Compton's First Lessons in Metal-working.	12mo,	1 50
Compton and De Groodt's The Speed Lathe	12mo,	1 50
Cromwell's Treatise on Toothed Gearing.	12mo,	1 50
Treatise on Belts and Pulleys.	12mo,	1 50
Dana's Text-book of Elementary Mechanics for Colleges and Schools.	12mo,	1 50
Dingey's Machinery Pattern Making	12mo,	2 00
Dredge's Record of the Transportation Exhibits Building of the World's Columbian Exposition of 1893.	4to half morocco,	5 00
Du Bois's Elementary Principles of Mechanics:		
Vol. I. Kinematics.	8vo,	3 50
Vol. II. Statics.	8vo,	4 00
Mechanics of Engineering. Vol. I.	Small 4to,	7 50
Vol. II.	Small 4to,	10 00
Durley's Kinematics of Machines.	8vo,	4 00
Fitzgerald's Boston Machinist.	16mo,	1 00
Flather's Dynamometers, and the Measurement of Power.	12mo,	3 00
Rope Driving.	12mo,	2 00
Goss's Locomotive Sparks.	8vo,	2 00
Locomotive Performance.	8vo,	5 00
* Greene's Structural Mechanics.	8vo,	2 50
Hall's Car Lubrication.	12mo,	1 00
Hobart and Ellis's High-speed Dynamo Electric Machinery. (In Press.)		
Holly's Art of Saw Filing.	18mo,	75
James's Kinematics of a Point and the Rational Mechanics of a Particle.	Small 8vo,	2 00
* Johnson's (W. W.) Theoretical Mechanics.	12mo,	3 00
Johnson's (L. J.) Statics by Graphic and Algebraic Methods.	8vo,	2 00
Jones's Machine Design:		
Part I. Kinematics of Machinery.	8vo,	1 50
Part II. Form, Strength, and Proportions of Parts.	8vo,	3 00
Kerr's Power and Power Transmissibn.	8vo,	2 00
Lanza's Applied Mechanics.	8vo,	7 50
Leonard's Machine Shop, Tools, and Methods.	8vo,	4 00
* Lorenz's Modern Refrigerating Machinery. (Pope, Haven, and Dean.)	8vo,	4 00
MacCord's Kinematics; or, Practical Mechanism.	8vo,	5 00
Velocity Diagrams.	8vo,	1 50
* Martin's Text Book on Mechanics, Vol. I, Statics.	12mo,	1 25
* Vol. 2, Kinematics and Kinetics	12mo,	1 50
Maurer's Technical Mechanics.	8vo,	4 00
Merriman's Mechanics of Materials.	8vo,	5 00
* Elements of Mechanics.	12mo,	1 00
* Michie's Elements of Analytical Mechanics.	8vo,	4 00
* Parshall and Hobart's Electric Machine Design.	4to, half morocco,	12 50
Reagan's Locomotives: Simple, Compound, and Electric. New Edition.	Large 12mo,	3 50
Reid's Course in Mechanical Drawing.	8vo,	2 00
Text-book of Mechanical Drawing and Elementary Machine Design.	8vo,	3 00
Richards's Compressed Air.	12mo,	1 50
Robinson's Principles of Mechanism.	8vo,	3 00
Ryan, Norris, and Hoxie's Electrical Machinery. Vol. I.	8vo,	2 50
Sanborn's Mechanics; Problems.	Large 12mo,	1 50
Schwamb and Merrill's Elements of Mechanism.	8vo,	3 00
Sinclair's Locomotive-engine Running and Management.	12mo,	2 00
Smith's (O.) Press-working of Metals	8vo,	3 00
Smith's (A. W.) Materials of Machines.	12mo,	1 00
Smith (A. W.) and Marx's Machine Design.	8vo,	3 00
Sorel's Carbureting and Combustion of Alcohol Engines. (Woodward and Preston.)	Large 8vo,	3 00

Spangler, Greene, and Marshall's Elements of Steam-engineering.....	8vo,	3 00
Thurston's Treatise on Friction and Lost Work in Machinery and Mill Work.....	8vo,	3 00
Animal as a Machine and Prime Motor, and the Laws of Energetics.	12mo,	1 00
Tillson's Complete Automobile Instructor	16mo,	1 50
	Morocco,	2 00
Warren's Elements of Machine Construction and Drawin'.....	8vo,	7 50
Weisbach's Kinematics and Power of Transmission. (Herrmann—Klein.)	8vo,	5 00
Machinery of Transmission and Governors. (Herrmann—Klein.)	8vo,	5 00
Wood's Elements of Analytical Mechanics.....	8vo,	3 00
Principles of Elementary Mechanics.....	12mo,	1 25
Turbines.....	8vo,	2 50
The World's Columbian Exposition of 1893	4to,	1 00

MEDICAL.

* Bolduan's Immune Sera	12mo,	1 50
De Fursac's Manual of Psychiatry. (Rosanoff and Collins.)....	Large 12mo,	2 50
Ehrlich's Collected Studies on Immunity. (Bolduan.).....	8vo,	6 00
* Fischer's Physiology of Alimentation.....	Large 12mo, cloth,	2 00
Hammarsten's Text-book on Physiological Chemistry. (Mandel.).....	8vo,	4 00
Lassar-Cohn's Practical Urinary Analysis. (Lorenz.).....	12mo,	1 00
* Paul's Physical Chemistry in the Service of Medicine. (Fischer.)....	12mo,	1 25
* Pozzi-Escot's The Toxins and Venoms and their Antibodies. (Cohn.)	12mo,	1 00
Rostoski's Serum Diagnosis. (Bolduan.).....	12mo,	1 00
Salkowski's Physiological and Pathological Chemistry. (Orndorff.).....	8vo,	2 50
* Satterlee's Outlines of Human Embryology	12mo,	1 25
Steel's Treatise on the Diseases of the Dog.....	8vo,	3 50
Von Behring's Suppression of Tuberculosis. (Bolduan.).....	12mo,	1 00
Woodhull's Notes on Military Hygiene	16mo,	1 50
* Personal Hygiene.....	12mo,	1 00
Wulling's An Elementary Course in Inorganic Pharmaceutical and Medical Chemistry	12mo,	2 00

METALLURGY.

Betts's Lead Refining by Electrolysis. (In Press.)		
Egleston's Metallurgy of Silver, Gold, and Mercury:		
Vol. I. Silver.....	8vo,	7 50
Vol. II. Gold and Mercury.....	8vo,	7 50
Goessel's Minerals and Metals: A Reference Book.....	16mo, mor,	3 00
* Iles's Lead-smelting.....	12mo,	2 50
Keep's Cast Iron.....	8vo,	2 50
Kunhardt's Practice of Ore Dressing in Europe.....	8vo,	1 50
Le Chatelier's High-temperature Measurements. (Boudouard—Burgess.)	12mo,	3 00
Metcalf's Steel. A Manual for Steel-users.....	12mo,	2 00
Müller's Cyanide Process.....	12mo,	1 00
Minet's Production of Aluminum and its Industrial Use. (Waldo.)....	12mo,	2 50
Robine and Lenglen's Cyanide Industry. (Le Clerc.).....	8vo,	4 00
Smith's Materials of Machines.....	12mo,	1 00
Thurston's Materials of Engineering. In Three Parts.....	8vo,	8 00
Part II. Iron and Steel.....	8vo,	3 50
Part III. A Treatise on Brasses, Bronzes, and Other Alloys and their Constituents.....	8vo,	2 50
Ulke's Modern Electrolytic Copper Refining.....	8vo,	3 00

MINERALOGY.

Barringer's Description of Minerals of Commercial Value. Oblong, morocco,	2 50
Boyd's Resources of Southwest Virginia.....	8vo,

Boyd's Map of Southwest Virginia.....	Pocket-book form.	2 00
* Browning's Introduction to the Rarer Elements.....	8vo,	1 50
Brush's Manual of Determinative Mineralogy. (Penfield.).....	8vo,	4 00
Chester's Catalogue of Minerals.....	8vo, paper,	1 00
	Cloth,	1 25
Dictionary of the Names of Minerals.....	8vo,	3 50
Dana's System of Mineralogy.....	Large 8vo, half leather,	12 50
First Appendix to Dana's New "System of Mineralogy.".....	Large 8vo,	1 00
Text-book of Mineralogy.....	8vo,	4 00
Minerals and How to Study Them.....	12mo,	1 50
Catalogue of American Localities of Minerals.....	Large 8vo,	1 00
Manual of Mineralogy and Petrography.....	12mo	2 00
Douglas's Untechnical Addresses on Technical Subjects.....	12mo,	1 00
Eakle's Mineral Tables.....	8vo,	1 25
Egleston's Catalogue of Minerals and Synonyms.....	8vo,	2 50
Goessel's Minerals and Metals: A Reference Book.....	16mo, mor.	3 00
Groth's Introduction to Chemical Crystallography (Marshall).....	12mo,	1 25
Iddings's Rock Minerals.....	8vo,	5 00
Johannsen's Key for the Determination of Rock-forming Minerals in Thin Sections. (In Press.)		
* Martin's Laboratory Guide to Qualitative Analysis with the Blowpipe.....	12mo,	60
Merrill's Non-metallic Minerals. Their Occurrence and Uses.....	8vo,	4 00
Stones for Building and Decoration.....	8vo,	5 00
* Penfield's Notes on Determinative Mineralogy and Record of Mineral Tests.	8vo, paper,	50
Tables of Minerals.....	8vo,	1 00
* Richards's Synopsis of Mineral Characters.....	12mo, morocco,	1 25
* Ries's Clays: Their Occurrence, Properties, and Uses.....	8vo,	5 00
Rosenbusch's Microscopical Physiography of the Rock-making Minerals. (Iddings.).....	8vo,	5 00
* Tillman's Text-book of Important Minerals and Rocks.....	8vo,	2 00

MINING.

Beard's Mine Gases and Explosions. (In Press.)		
Boyd's Resources of Southwest Virginia.....	8vo,	3 00
Map of Southwest Virginia.....	Pocket-book form,	2 00
Douglas's Untechnical Addresses on Technical Subjects.....	12mo,	1 00
Eissler's Modern High Explosives.....	8vo,	4 00
Goessel's Minerals and Metals: A Reference Book.....	16mo, mor.	3 00
Goodyear's Coal-mines of the Western Coast of the United States.....	12mo,	2 50
Ihlseng's Manual of Mining.....	8vo,	5 00
* Iles's Lead-smelting.....	12mo,	2 50
Kunhardt's Practice of Ore Dressing in Europe.....	8vo,	1 50
Miller's Cyanide Process.....	12mo,	1 00
O'Driscoll's Notes on the Treatment of Gold Ores.....	8vo,	2 00
Robine and Lenglen's Cyanide Industry. (Le Clerc.).....	8vo,	4 00
Weaver's Military Explosives.....	8vo,	3 00
Wilson's Cyanide Processes.....	12mo,	1 50
Chlorination Process.....	12mo,	1 50
Hydraulic and Placer Mining. 2d edition, rewritten.....	12mo,	2 50
Treatise on Practical and Theoretical Mine Ventilation.....	12mo,	1 25

SANITARY SCIENCE.

Bashore's Sanitation of a Country House.....	12mo,	1 00
* Outlines of Practical Sanitation.....	12mo,	1 25
Folwell's Sewerage. (Designing, Construction, and Maintenance.).....	8vo,	3 00
Water-supply Engineering.....	8vo,	4 00

Fowler's Sewage Works Analyses.....	12mo,	2 00
Fuertes's Water and Public Health.....	12mo,	1 50
Water-filtration Works.....	12mo,	2 50
Gerhard's Guide to Sanitary House-inspection.....	16mo,	1 00
Sanitation of Public Buildings.....	12mo,	1 50
Hazen's Filtration of Public Water-supplies.....	8vo,	3 00
Leach's The Inspection and Analysis of Food with Special Reference to State Control.....	8vo,	7 50
Mason's Water-supply. (Considered principally from a Sanitary Standpoint)	8vo,	4 00
Examination of Water. (Chemical and Bacteriological).....	12mo,	1 25
* Merriman's Elements of Sanitary Engineering.....	8vo,	2 00
Ogden's Sewer Design.....	12mo,	2 00
Prescott and Winslow's Elements of Water Bacteriology, with Special Reference to Sanitary Water Analysis.....	12mo,	1 25
* Price's Handbook on Sanitation.....	12mo,	1 50
Richards's Cost of Food. A Study in Dietarics.....	12mo,	1 00
Cost of Living as Modified by Sanitary Science.....	12mo,	1 00
Cost of Shelter.....	12mo,	1 00
Richards and Woodman's Air, Water, and Food from a Sanitary Standpoint.....	8vo,	2 00
* Richards and Williams's The Dietary Computer.....	8vo,	1 50
Rideal's S wage and Bacterial Purification of Sewage.....	8vo,	4 00
Disinfection and the Preservation of Food.....	8vo,	4 00
Turneure and Russell's Public Water-supplies.....	8vo,	5 00
Von Behring's Suppression of Tuberculosis. (Bolduan.).....	12mo,	1 00
Whipple's Microscopy of Drinking-water.....	8vo,	3 50
Wilson's Air Conditioning. (In Press.).....		
Winton's Microscopy of Vegetable Foods.....	8vo,	7 50
Woodhull's Notes on Military Hygiene.....	16mo,	1 50
* Personal Hygiene.....	12mo,	1 00

MISCELLANEOUS.

Association of State and National Food and Dairy Departments (Interstate Pure Food Commission):		
Tenth Annual Convention Held at Hartford, July 17-20, 1906....	8vo,	3 00
Eleventh Annual Convention, Held at Jamestown Tri-Centennial Exposition, July 16-19, 1907. (In Press.)		
Emmons's Geological Guide-book of the Rocky Mountain Excursion of the International Congress of Geologists.....	Large 8vo,	1 50
Ferrel's Popular Treatise on the Winds.....	8vo,	4 00
Gannett's Statistical Abstract of the World.....	24mo,	75
Gerhard's The Modern Bath and Bath-houses. (In Press.)		
Haines's American Railway Management.....	12mo,	2 50
Ricketts's History of Rensselaer Polytechnic Institute, 1824-1894..	Small 8vo,	3 00
Rotherham's Emphasized New Testament.....	Large 8vo,	2 00
Standage's Decorative Treatment of Wood, Glass, Metal, etc. (In Press.)		
The World's Columbian Exposition of 1893.....	4to,	1 00
Winslow's Elements of Applied Microscopy.....	12mo,	1 50

HEBREW AND CHALDEE TEXT-BOOKS.

Green's Elementary Hebrew Grammar.....	12mo,	1 25
Hebrew Chrestomathy.....	8vo,	2 00
Gesenius's Hebrew and Chaldee Lexicon to the Old Testament Scriptures. (Tregelles.).....	Small 4to, half morocco,	5 00
Letteris's Hebrew Bible.....	8vo,	2 25

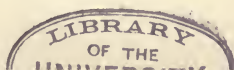

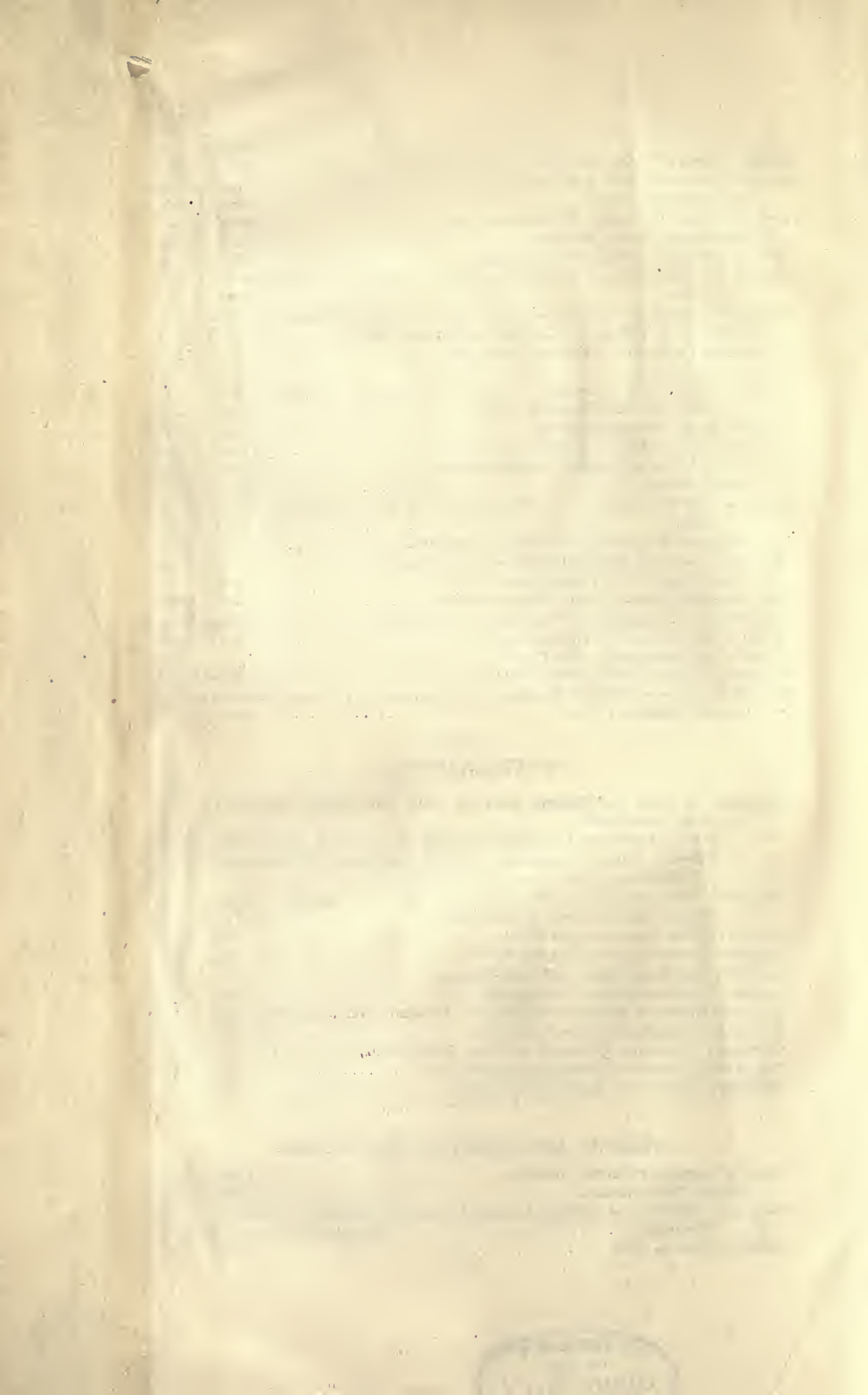

THIS BOOK IS DUE ON THE LAST DATE
STAMPED BELOW

AN INITIAL FINE OF 25 CENTS
WILL BE ASSESSED FOR FAILURE TO RETURN
THIS BOOK ON THE DATE DUE. THE PENALTY
WILL INCREASE TO 50 CENTS ON THE FOURTH
DAY AND TO \$1.00 ON THE SEVENTH DAY
OVERDUE.

DEC 9 1940M

DEC 14 1932

DEC 15 1932

FEB 22 1941M

OCT 2 1935

MAY 5 1941M

SEP 18 1937

MAY 11 1945

OCT 19 1937

16 JUL 53

MAR 2 1953 LW

DEC 10 1939

30 MAR '56 KK

NOV 27 1940

MAR 1 6 1956 LW

290 ml

1. COPPER WIRE TABLE.*

Am. Gauge, B. & S. No.	Diam., Mils.	Area, Circular Mils (d ²). 1 Mil = .001 inch.	Copper 75° Fahr.			
			R. Ohms per 1000 Feet.	Feet per Ohm.	Ohms per Pound.	Feet per Pound.
∞	∞.000	211600.00	.04906	20383.	.000076736	1.561
000	409.640	167805.00	.06186	16165.	.00012180	1.969
00	364.800	133079.40	.07801	12820.	.00019423	2.482
0	324.860	105534.00	.09831	10172.	.00030772	3.130
						3.947
						4.977
						6.276
						7.914
						9.980
						12.58
						15.87
						20.01
						25.23
						31.82
						40.12
						50.59
						63.79
						80.44
						101.4
						127.9
						161.3
						203.4
19	35.090	1200.10	0.0552	124.14	2.007	256.5
20	31.961	1021.50	10.163	98.401	3.2926	323.4
21	28.462	810.10	12.815	78.037	5.2355	407.8
22	25.347	642.70	16.152	61.911	8.3208	514.2
23	22.571	509.45	20.377	49.106	13.238	648.4
24	20.100	404.01	25.695	38.918	21.050	817.6
25	17.900	320.40	32.400	30.864	33.466	1031.
26	15.940	254.01	40.868	24.469	53.083	1300.
27	14.195	201.50	51.519	19.410	84.644	1639.
28	12.641	159.79	64.966	15.393	134.56	2067.
29	11.257	126.72	81.921	12.207	213.96	2607.
30	10.025	100.50	103.30	9.6812	340.25	3287.
31	8.928	79.71	129.63	7.6818	539.55	4145.
32	7.950	63.20	164.26	6.0880	860.33	5227.
33	7.080	50.13	207.08	4.8290	1367.3	6501.
34	6.304	39.74	261.23	3.8281	2175.5	8311.
35	5.614	31.52	329.35	3.0363	3458.5	10480.
36	5.000	25.00	415.24	2.4081	5497.4	13210.
37	4.453	19.83	523.76	1.9093	8742.1	16660.
38	3.965	15.72	660.37	1.5143	13899.	21010.
39	3.531	12.47	832.48	1.2012	22047.	26500.
40	3.144	9.89	1049.7	.9527	35055.	33410.

* Copper : Resistance of one mil-foot of pure soft copper at 75° F. is 10.381 ohms ; resistance of hard copper is 1.0226 times that of soft copper. Weight in pounds per mil-foot .00003028. (By permission of the Pittsburg Reduction Co.)

